



# User Guide for The Titan Switch Range

## DP\_26, F\_5, L\_3, P\_26, T\_17 & V\_26

**IMPORTANT: READ CAREFULLY BEFORE USE AND KEEP FOR FUTURE REFERENCE**

### Symbols Used

	CAUTION/Requirement for safe use
	Hazardous area installation requirement



The Titan must be maintained, installed, repaired & decommissioned by qualified personnel only.



Hazardous area products must be installed in accordance with IEC/EN 60079-14.



The Titan must not be used outside of its specifications. This may adversely affect performance, product life and may cause a hazard to people, animals and the environment. Check the product's identification label before installation to ensure the correct product has been selected.

### Contents

Symbols Used .....	1	Environmental Limitations .....	4
Contents .....	1	Electrical Installation.....	5
Description of The Equipment .....	1	Set Point Adjustment .....	6
Storage.....	1	Mechanical Installation .....	7
General Dimensions & Features.....	2	Maintenance .....	13
Product Identification.....	2	Troubleshooting .....	13
CE Marking .....	2	Spares & repair .....	13
Standards Applied .....	3	Materials of Construction .....	14
Hazardous Area Marking.....	3	Disposal .....	14
Conditions for Safe Use (X Conditions) .....	4	Contact Details.....	14
Pressure & Temperature Ratings .....	4		

### Description of The Equipment

The Titan is designed to be used in volatile and hazardous atmospheres to sense changes in flow, level, pressure, or temperature using mechanical actuators and converting the physical change into an electrical signal.

### Storage

The Titan can be stored in temperatures of **-40°C to +85°C**, excluding T\_6 types with L\*/M\* ranges that can be stored at **-20°C to 85°C**. If being stored in a damp/humid environment, it is recommended to store the product without its packaging.

## General Dimensions & Features

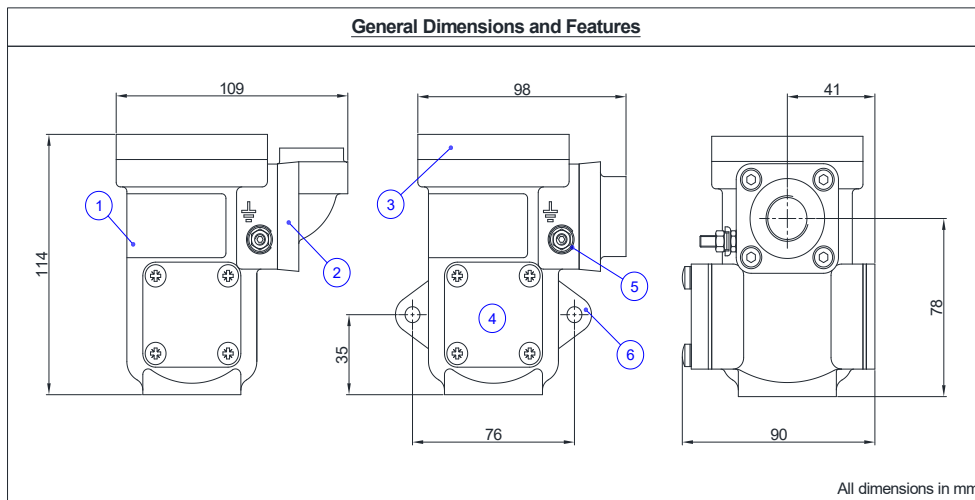

Features	
1	Identification Label
2	M20 x 1.5 Electrical Entry (angled or straight)
3	Top Cover & Certification Label
4	Adjustment Cover
5	External Earth
6	Standard Mounting Bracket (A code)

## Product Identification

Please see the identification label. Ensure that the correct type of instrumentation is selected before installation.

<b>TYPE</b>	Titan Flameproof Pressure Switch	Pyropress Limited Plymouth England PL7 4JH +44(0)1752 333939 www.pyropress.com
<b>MODEL</b>	PF261S1B/*	
<b>PROCESS TEMP. RANGE</b>	min. to max.	<b>SERIAL No.</b> *****
<b>MAX WORKING PRESSURE</b>	max.	
<b>TAG No.</b>		<b>RANGE</b> min. setting to max.

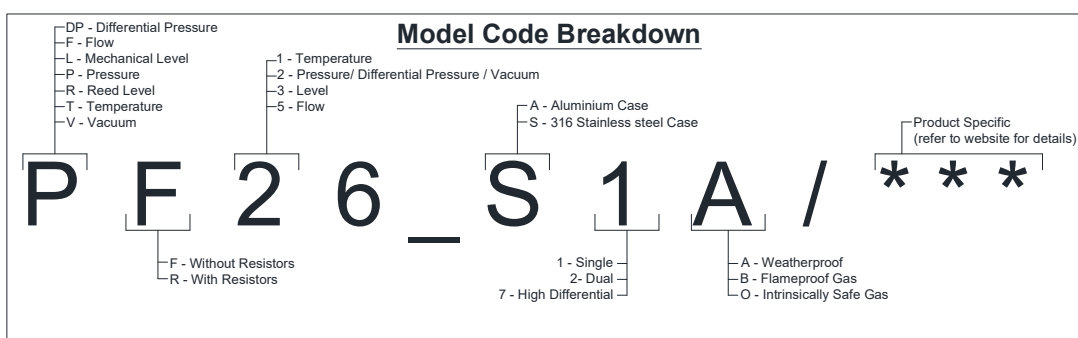

## CE Marking

Titan products for use in non-hazardous (weatherproof) applications carry a CE mark to signify conformity with the Low Voltage Directive 2014/35/EU.

Titan products for use in explosive atmospheres carry a CE mark to signify conformity with the ATEX Directive 2014/34/EU.

All Titan switch types fall within the Sound Engineering Practice category, as defined by chapter 1, article 4, paragraph 3 of the Pressure Equipment Directive 2014/68/EU. For this reason, the CE mark on the Titan does **not** signify conformance with the Pressure Equipment Directive.

## Standards Applied

For Non-Explosive Atmosphere (Weatherproof) Applications:

- EN 61010-1:2010
- IEC 61010-1:2010

For Explosive Atmosphere Applications:

**Flameproof, Ex db – (Zones 1 & 2) (CAT 2 & CAT 3)**

- EN 60079-0:2018
- EN 60079-1:2014
- IEC 60079-0:2017
- IEC 60079-1:2014

**Intrinsic Safety, Ex ia – (Zones 0, 1, & 2) (CAT 1, CAT 2 & CAT 3)**

- EN 60079-0:2018
- EN 60079-11:2012
- IEC 60079-0:2017
- IEC 60079-11:2011

## Hazardous Area Marking

**Flameproof, without resistors (Ex db)**



**Flameproof, with resistors (Ex db)**

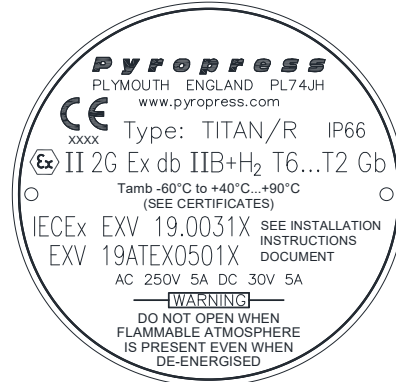

**Intrinsically safe, without resistors  
(Ex ia)**

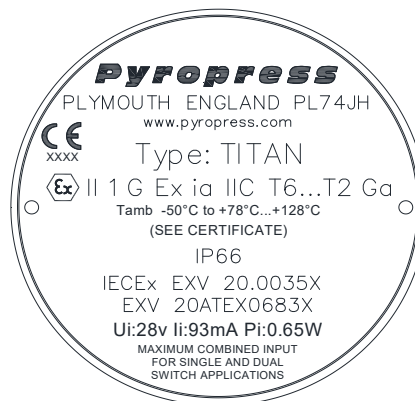

Ensure the correct protection method has been selected for the application.



## Conditions for Safe Use (X Conditions)

### Ex db

- Flameproof joints not intended for repair.
- Suitably rated cable must be selected if the equipment is subject to service temperatures of 70°C or greater.
- Fasteners associated with the flange flamepaths possess a minimum yield strength of 240N/mm<sup>2</sup>.

### Ex ia

- For Ga installations – The equipment may be constructed using aluminium for the housing and internal parts and may only be used when the ignition hazard assessment shows there is no risk of ignition from incendive impact or abrasion sparks.

### All Titan Products

**WARNING:** End-users are advised to carry out assessments in accordance with the requirements of appropriate, recognised standards. The person or persons undertaking this task must be suitably qualified.

## Pressure & Temperature Ratings

### Process Temperature:

Please see the product identification label for the process temperature range, max working pressure & range.

### Ambient Temperature:

Maximum ambient temperature permissible, changes depending on the Titan' application.

Type	Process range	Ambient range
T_6 (Rigid Stem Temperature types)	200°C to 240°C range	-40°C to +75°C
	175°C to 225°C range	
	150°C to 200°C range	-40°C to +80°C
Fitted with a High Differential Microswitch (7 code)	<150°C	-40°C to +65°C
All other types and ranges	<150°C	-40°C to +85°C

Upper ambient temperatures will be further restricted if products are:

### Ex II 2 G Ex db IIC certified

- Installed in a T6 environment: +75°C

### OR Ex II 1 G Ex ia IIC certified

- installed in a T6 environment: +78°C



Upper temperature limits for ambient temperature can be further restricted. If the temperature on the certificate is lower than the temperature range specified on the identification label, the one on the certificate prevails.

## Environmental Limitations

- Titan products are rated IP66 in accordance with IEC/EN 60529.
- Titan products should not be installed at altitudes greater than 2000m.
- Contact Pyropress for information regarding shock and vibration limits or SIL information.

## Electrical Installation



### Weatherproof products

Terminals must not be accessed unless the product has been electrically isolated.



### Flameproof (Ex db) products

Do not remove the top cover whilst a flammable atmosphere is present, even when de-energized.



### Intrinsically safe (Ex ia) products

The top cover can be removed when the switch is energized, but installation should only be carried out when the product has been electrically isolated.

**Single microswitch options**  
(codes 1 & 7)

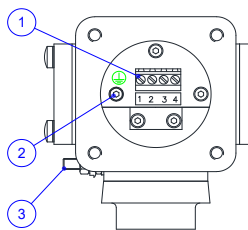

**Dual microswitch option**  
(code 2)

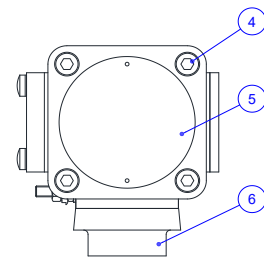
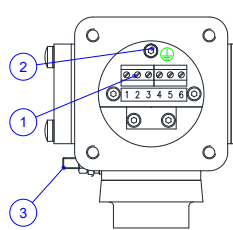

Electrical features	
1	Slotted Screw Terminal
2	Protective Conductor Terminal
3	External Earth
4	M6 Hex Screw
5	Top Cover
6	Electrical Entry

## Ratings

Weatherproof & Flameproof (Ex db)	250VAC 5A or 30VDC 5A
Intrinsically safe (Ex ia)	Ui:28Vdc Ii:93mA Pi:0.65W Ci:0F Li:0H



We recommend that suitably rated cable glands, adaptors, or blanking plugs with an IP66 rating are fitted.



Flameproof (Ex db) certified products must be fitted with appropriately rated Ex db certified cable glands, adaptors or blanking plugs with an IP66 rating.



Electrical Entries can be rotated if required. Use a 4mm Hex Key to loosen the Screws and rotate the entry as required. It is imperative that the Electrical Entry Screws are not lost or replaced with other screws as these screws make up part of the Flameproof concept and must be of a certain strength. Contact Pyropress for replacement parts if required.

## Earthing



The Titan must be earthed to ensure safe use. Use a conductor of at least 4mm<sup>2</sup> for the external earth & a conductor up to 2.5mm<sup>2</sup> for the protective conductor terminal.



Flameproof (Ex db) and Intrinsically safe (Ex ia) products should be earthed in accordance with 60079-14.

## Over Current Protection



Titan Weatherproof and Flameproof (Ex db) switches should be fitted with a maximum of 5A over current protection with the ring or separate breaker suitably located, easily reached and marked as the disconnecting device for this instrument.

## Wiring



Cables with an operating temperature greater than 105°C must be used.

The screw terminals can accept conductors of a cross-sectional area of up to 2.5mm<sup>2</sup> solid or up to 1.5mm<sup>2</sup> flexible.

All types, excluding the Vertical Reed Level are wired as follows:

	For rising signal	For falling signal
Common	Terminal 1 (and terminal 4)	Terminal 1 (and terminal 4)
Normally Open	Terminal 2 (and terminal 5)	Terminal 3 (and terminal 6)
Normally Closed	Terminal 3 (and terminal 6)	Terminal 2 (and terminal 5)



To prevent damage to the instrument, we recommend wiring the terminals prior to tightening cable gland and carrying out any mechanical installation whilst the mains is disconnected.

## To Connect the Terminals

1. Undo the 4 Hex Screws using a 5mm hex key to remove the Top Cover.
2. Wire Terminals and Earthing, then tighten to 0.5Nm. **CAUTION:** Do not over tighten.
3. Tighten any cable glands and adaptors. **CAUTION:** ensure wires are not pulled tight.
4. Ensure mating faces are clean, check the O-ring seal is still in position and replace to Top Cover.
5. Tighten the 4 hex screws equally to 8Nm.



For flameproof (Ex db) It is imperative that the Top Cover screws are not lost or replaced with other screws as these screws make up part of the flameproof concept and must be of a certain strength. Contact Pyropress for replacement parts if required.



The information on the Top Cover is unique to the unit it is supplied with. Do not mix the Top Covers.

## Set Point Adjustment

The Titan is supplied calibrated as requested at point of sale. If a fixed set point was supplied, no further adjustment should be required. If required, the set point can be adjusted by following the steps below.

### Adjustment Chamber (excluding T\_17 Rigid Stem Temperature, L\_3 Level switches)

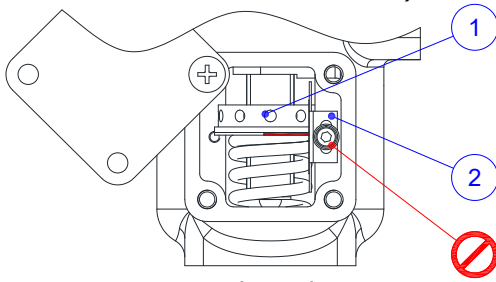

Adjustment Features	
1	Adjuster Screw
2	Scale (for indication only)

### Adjustment Chamber (T\_17 Rigid Stem Temperature ONLY)

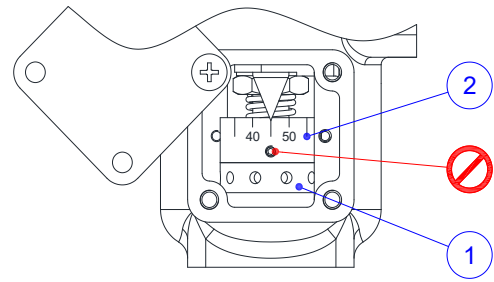

1. Remove the Adjustment Cover Screws (using a Posi-drive screwdriver) Washers, and Gaskets. **CAUTION:** Do not lose any of these components as they ensure an environmental seal. Contact Pyropress for spares if required.
2. Insert a 3mm Tommy Bar (or 2.5mm Hex Key) into the hole in the Adjuster Screw and rotate the Adjuster Screw to the desired set point lining the indicator up with the scale and verify with a pressure gauge.
3. Replace the Adjustment Cover, Gasket, Washers and Screws. Tighten the Screws to 1.5Nm. **WARNING:** Take care not to over tighten as this will distort the Gasket.

## Mechanical Installation

For this part, first read the **General Information** section and then navigate to your product type.

### General Information



Before undertaking any mechanical installation, ensure that all switch wiring has been completed and left disconnected at the mains side and any holes (if) required for mounting have been drilled.



In the case of pressure seal failure, Titan switches vent from 4 holes located above the process entry behind the Sealing Band. Should any pressure seal fail, the process media will vent through these holes.

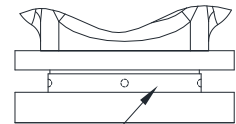

Sealing Band

- The Titan can be mounted in any orientation (excluding the 8" DP\_26, P\_26 & V\_26 Differential Pressure, Ultra low Pressure & Vacuum and Level types).
- If products are being fitted to a system where fluid flow can become unstable and cause pressure to pulsate or surge rapidly, it is imperative that a means of protecting the sensing element be provided; by adding a pressure snubber or over-range protector for example.
- If products are being fitted to a system where the process temperature could exceed the limits stated for that configuration (**see the identification label**), they must be remote mounted to allow for enough heat dissipation.
- Products should always be mounted such that any free movement is minimal. To avoid damage from vibration or accidental impact, products mounted via the process connection should be properly supported.
- We recommend that PTFE tape is used on tapered process connections (to improve the seal and prevent cold welding) and appropriately sized bonded seals on parallel process connections.
- All compression fittings must be sufficiently tightened to prevent leakage.
- The Titan can be supplied with accessories such as chemical seals, gauges, and manifolds. Please refer to any separate documentation supplied when installing accessories not covered by this user guide.
- We recommend that anti-vibration Washers are used when mounting the product.

- For products fitted with a 2" (52mm) pipe bracket, place the 'U' Bolt around the pipe, slide the saddle onto the 'U' Bolt, feed the switches mounting bracket onto the 'U' Bolt and then tighten the 2 x M8 Full Nuts.

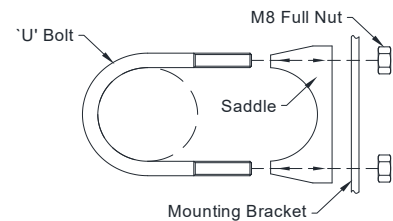

8" - D\_266, P\_266 & V\_266, (Differential Pressure, Pressure & Vacuum)

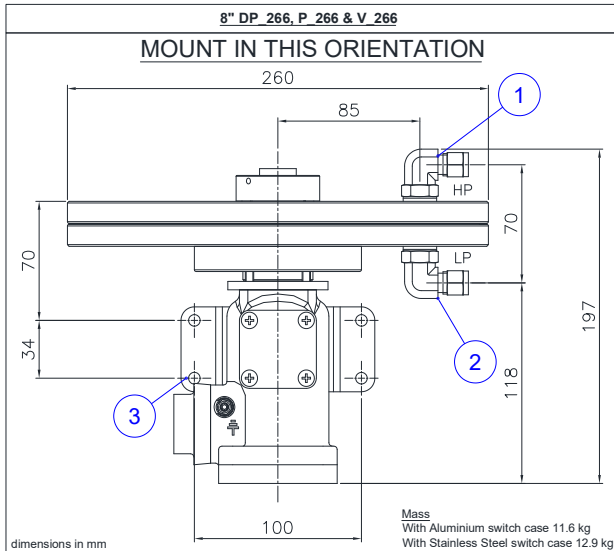

8" D_266, P_266 & V_266 Differential Pressure, Ultra Low Pressure & Vacuum	
1	High-Pressure Entry
2	Low-Pressure Entry
3	Bracket

This version **must** be mounted as shown. If mounted in any other orientation, the switch may not operate within the specification.

For P\_266 versions the Low-Pressure Entry is fitted with a vented plug.

For V\_266 versions the High-Pressure Entry is fitted with a vented plug.

**To Mount:** Feed 4 x M6 Screws (or equivalent) with Washers through the bracket.

1" & 3" - D\_266, P\_266 and V\_266 (Differential Pressure, Pressure & Vacuum)

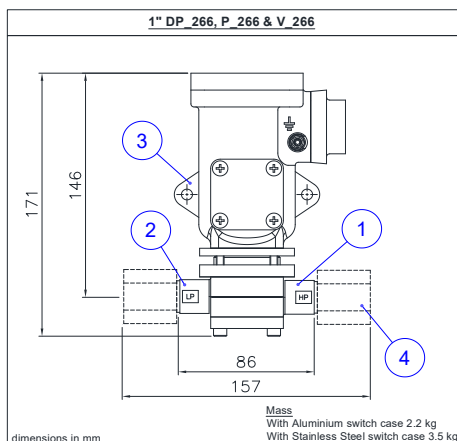

1" & 3" D_266, P_266 & V_266 Differential Pressure & Vacuum	
1	High-Pressure Entry
2	Low-Pressure Entry
3	Bracket
4	1/2" Process Adaptor (option)

For P\_266 versions the Low-Pressure Entry is fitted with a vented plug.

For V\_266 versions the High-Pressure Entry is fitted with a vented plug.

**To mount:** Feed 2 x M6 Screws (or equivalent) with Washers through the bracket.

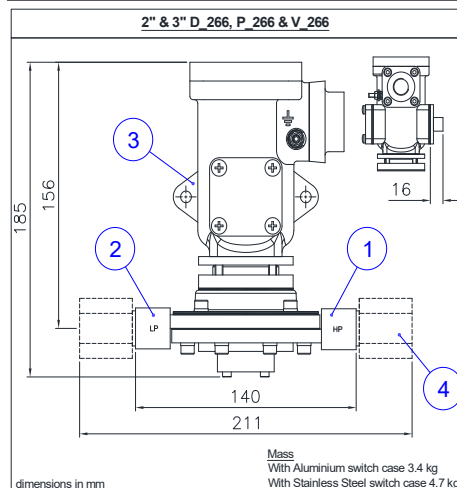



### 3" & 4" - P\_261 (Low Pressure)

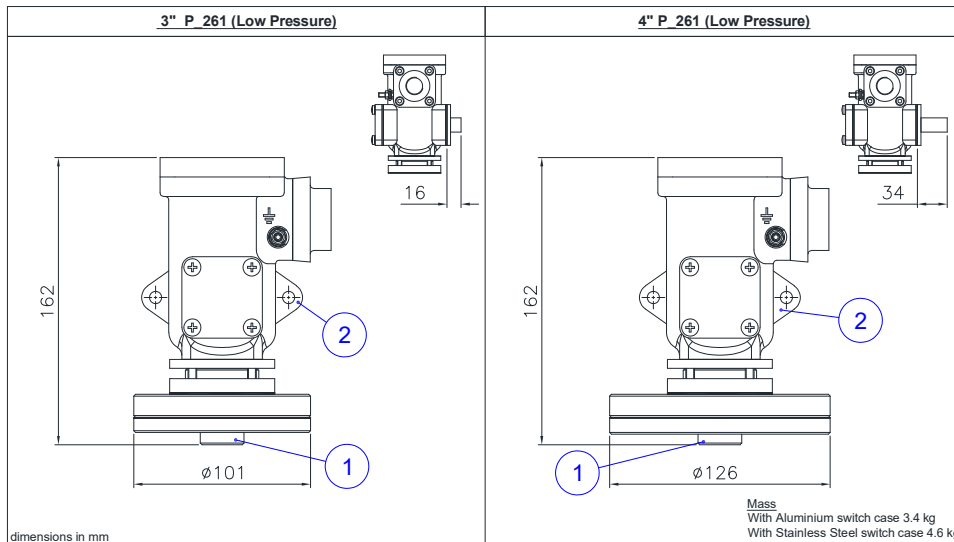

3" & 4" P_261 Low Pressure	
1	Process Entry
2	Bracket

**To mount:** Feed 2 x M6 (or equivalent) Screws with Washers through the bracket.

### Diaphragm - P\_261 & P\_262 (Medium Pressure)

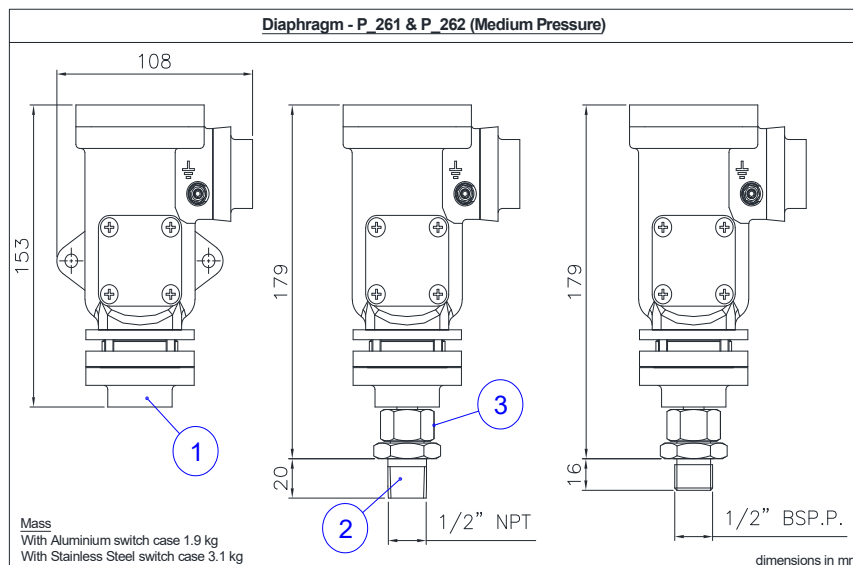

Diaphragm P_261 & P262 Medium Pressure	
1	Female Process Entry
2	Stem head
3	Coupling Nut

**To mount:** Case mounted or swivel connection.

**Swivel Connection:** Loosen coupling nut from the Stem Head → Tighten the Stem Head into your assembly → Holding the Switch Case in the desired position, tighten the Coupling Nut.

### Flush Diaphragm - P\_261 (Medium Pressure)

Pyropress supply many types of flanges based on system requirements. Flanges should be installed in accordance with their relevant standards (ANSI/ASME or ISO for example).

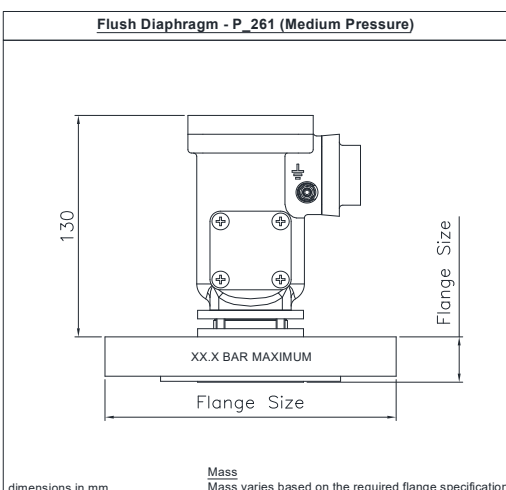

Take note of any marking etched or stamped into the flange to ensure safe use.

Check flange surfaces are clean to prevent contamination.

Ensure any gasket material is suitable for the process medium.

If liquid gasket is being applied, ensure the manufacturers cure time is adhered to prevent leakage.

Piston - P\_263 & P\_264 (High Pressure)

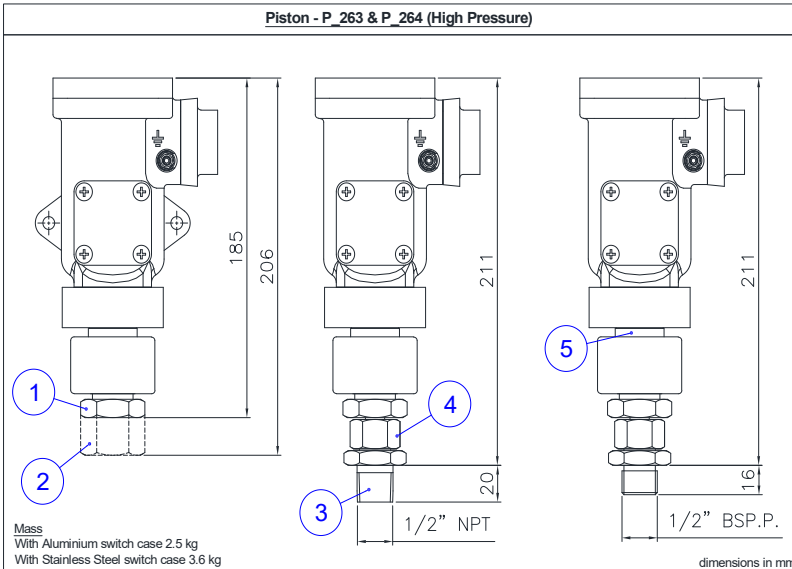

Piston P_263 & P_264 High Pressure	
1	1/4" Female Process Entry
2	1/2" Female Process Entry
3	Stem Head
4	Coupling Nut
5	Sealing Band

**To mount:** Case mounted or swivel connection.

**Swivel Connection:** Loosen Coupling Nut from the Stem Head → Tighten the Stem Head into your assembly → Holding the switch case in the desired position, tighten the Coupling Nut.



The Sealing Band allows process media to vent if a pressure seal fails.

Temperature - T\_171 & T\_172 Rigid Stem

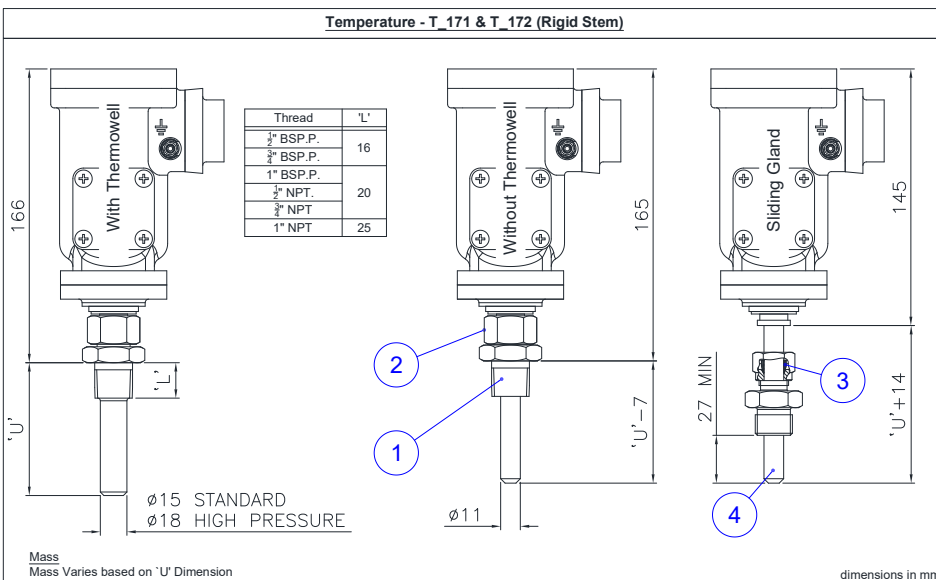

Temperature T_171 & T_172 (Rigid Stem)	
1	Stem Head/Thermowell
2	Coupling Nut
3	Olive
4	Temperature Probe

**To Mount:** Loosen Coupling Nut from the Stem Head/Thermowell → Tighten the Stem Head/Thermowell into your assembly → Holding the Switch Case in the desired position, tighten the Coupling Nut.

For variations installed with a flange please follow this part and refer to the "Flush Diaphragm" mechanical installation section.



**For Sliding gland types:** Torque coupling nut to 20Nm. Do not over tighten as this will damage the olive/temperature probe.

Temperature – T\_17 Capillary

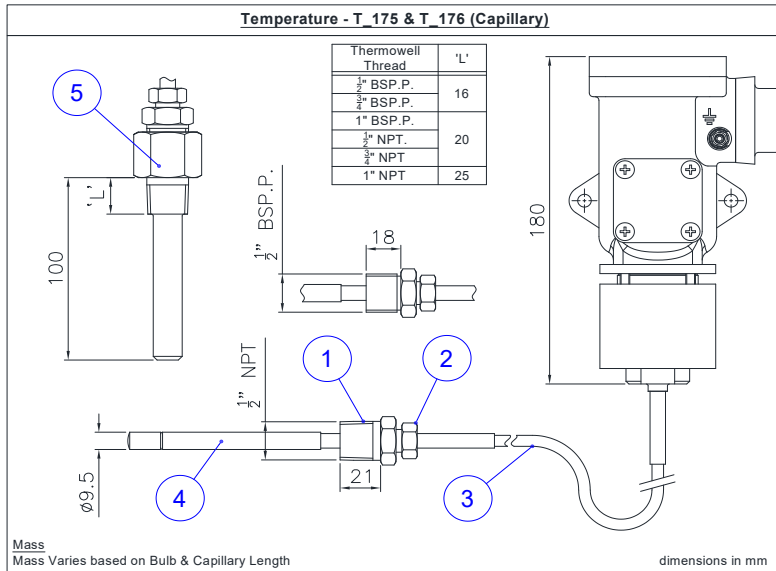

**Temperature T\_17 (Capillary)**

1	Stem Head
2	Coupling nut
3	Capillary
4	Bulb
5	Thermowell

**To mount:** Case mounted.

**Process Entry Connection:** Loosen Coupling Nut from the Stem Head/Thermowell → Tighten the Stem Head/Thermowell into your assembly → Holding the Switch Case in the desired position, tighten the Coupling Nut.

Mechanical level – L\_34 Horizontal

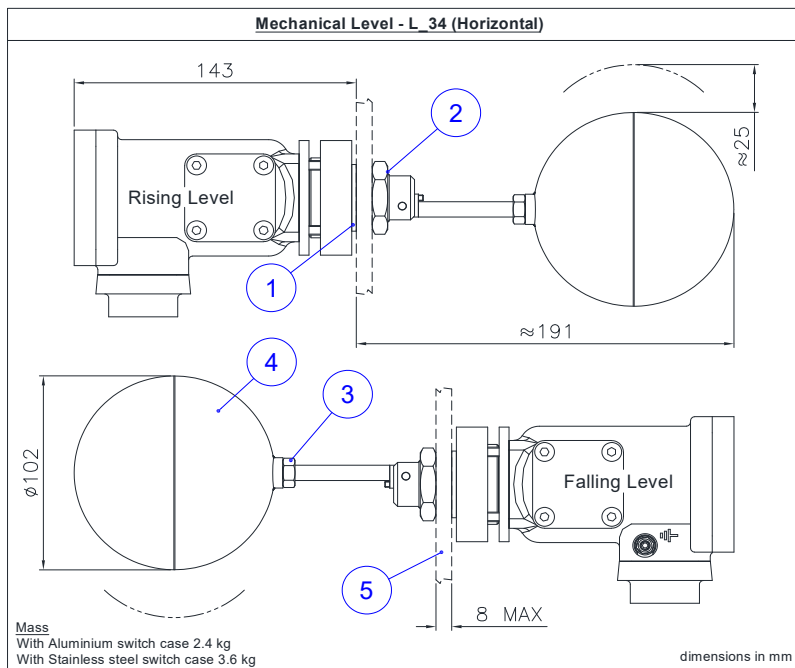

**Mechanical Level L\_34 (Horizontal)**

1	Bonded seal
2	Locknut
3	Nut
4	Float
5	Tank wall

**Tank wall hole size:** Ø27mm

Mount in the orientation shown depending on the required set point.

**To mount:** remove the Locknut but keep the Bonded Seal in place → feed the assembly through the tank wall → Holding the Switch Case in the desired position, tighten the Locknut → screw the Float onto the assembly, holding the Float with your hand, tighten the Nut.

For variations installed with a flange please follow this section and refer to the "Flush Diaphragm" mechanical installation section.

Mechanical Level – L\_35 Vertical

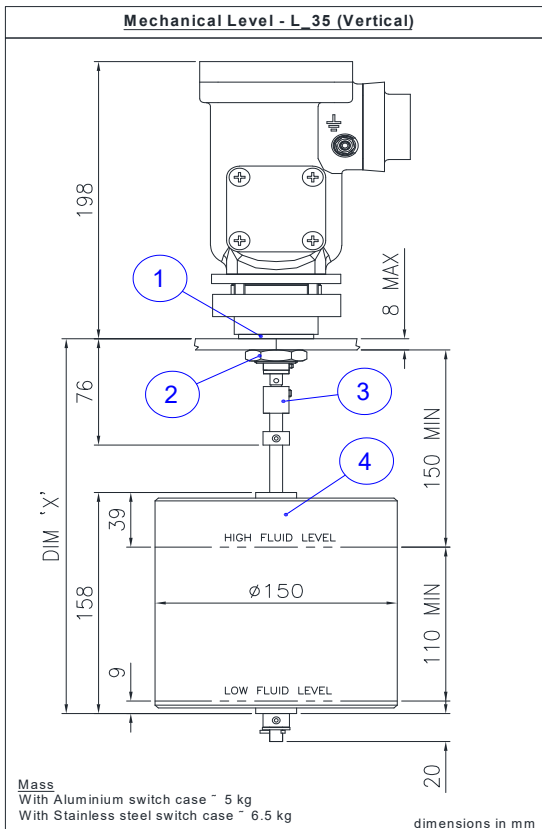

Mechanical Level L_35 (Vertical)	
1	Bonded Seal
2	Locknut
3	Locking Collar
4	Float

Tank wall hole size: Ø27mm

Mount in the orientation shown.

**To mount:** remove the Locknut but keep the Bonded Seal in place → Feed the assembly through the Tank Wall → Holding the Switch Case into the desired position, tighten the Locknut → Take the float assembly, feed the Locking Collar over the Shaft and tighten the Set Screw in the Locking Collar.

For variations installed with a flange please follow this section and refer to the "flush diaphragm" mechanical installation.

Flow – F\_503 All types

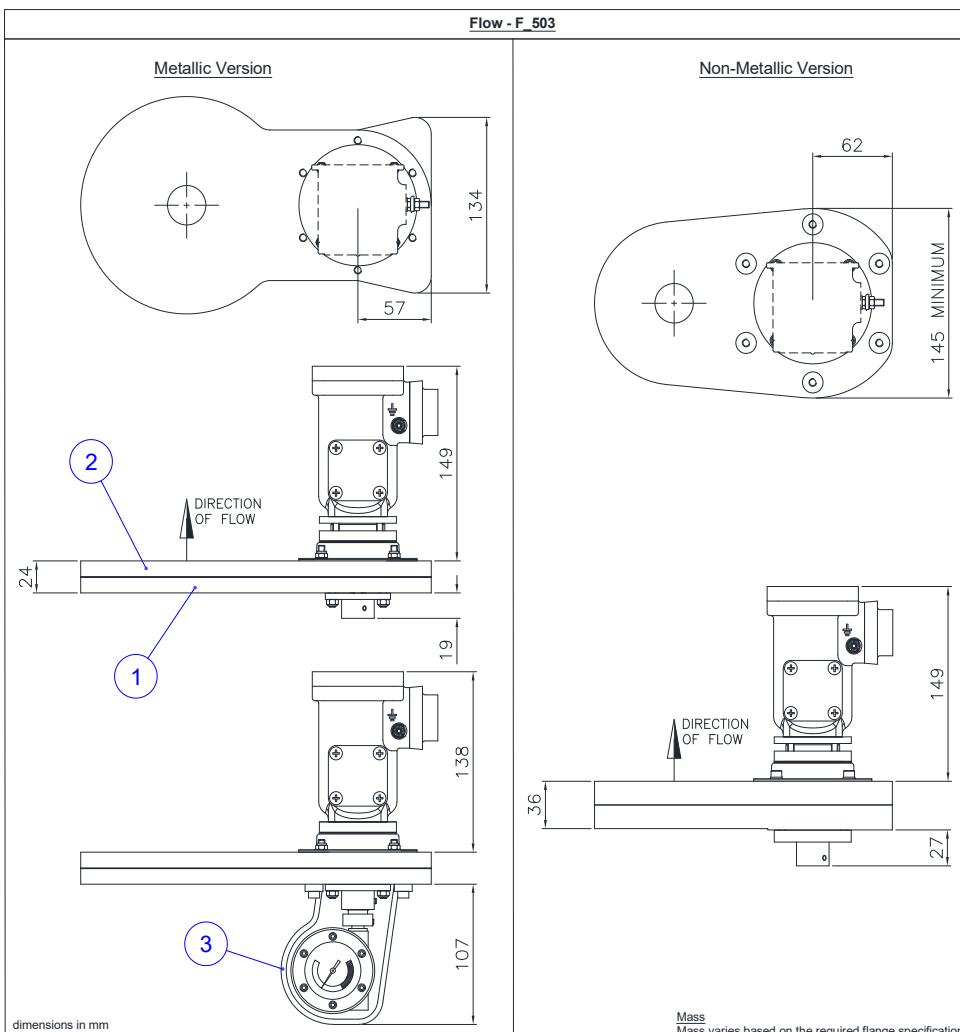

Flow - F_503	
1	Inlet Plate
2	Outlet Plate
3	Indicator (option)

Pyropress supply many types of flanges based on system requirements. Flanges should be installed in accordance with their relevant standards (ANSI/ASME or ISO for example).

Check flange surfaces are clean to prevent contamination.

Ensure any gasket material is suitable for the process medium.

If liquid gasket is being applied, ensure the manufacturers cure time is adhered to prevent leakage.

## Maintenance



Before undertaking any maintenance, ensure that the Titan is de-energised and isolated from pressurised media. Check that any surfaces are cool to the touch.



Flameproof (Ex db) must not have their top covers removed when an explosive atmosphere is present even if de-energised.

Maintenance procedure	Frequency*
Check process and electrical connection remain tight	Every 12 months
Cycle product if not in use	
Check ePTFE vents for damage (low pressure only)	
Replace seals and diaphragms	Every 3-5 years
Replace microswitch assemblies	Every 5-10 years

\*depending on usage

## Troubleshooting

Problem	Likely cause	Solution
Leak of media	<ul style="list-style-type: none"> <li>Diaphragm/O-ring failure.</li> </ul>	<ul style="list-style-type: none"> <li>Replace diaphragm/O-ring.</li> </ul>
Shift in set point	<ul style="list-style-type: none"> <li>Excessive shock or impact.</li> <li>Diaphragm or O-ring at end of life.</li> </ul>	<ul style="list-style-type: none"> <li>Re-adjust the set point.</li> <li>Replace diaphragm/O-ring.</li> </ul>
Slow response	<ul style="list-style-type: none"> <li>Media too viscous.</li> <li>Blockage in system.</li> <li>Valve not fully opened within system.</li> </ul>	<ul style="list-style-type: none"> <li>Use a chemical seal.</li> <li>Ensure lines are free of debris.</li> <li>Ensure valves are fully opened.</li> </ul>
No signal or intermittent signal	<ul style="list-style-type: none"> <li>Microswitch failure.</li> <li>Diaphragm/O-ring failure.</li> <li>Loose electrical connection.</li> </ul>	<ul style="list-style-type: none"> <li>Replace microswitch.</li> <li>Replace diaphragm/O-ring.</li> <li>De-energize the system and tighten electrical connection.</li> </ul>

**Note:** Replace only with Pyropress original parts

## Spares & Repair

Diaphragm, pressure seal and environmental seal kits are available for the following switch types.

- Vacuum (V\_266)
- Ultra-low pressure (P\_266)
- Low pressure (P\_261)
- Medium pressure (P\_261 & P\_262)
- High pressure piston (P\_263 & P\_264)
- Differential pressure (D\_266)

Fully assembled and pressure tested high-pressure piston (P\_263 & P\_264) assemblies are available for onsite repair.

Standard and high differential Single/dual microswitch assemblies are also available.

All switches should be thoroughly tested before re-introducing them into service. It is likely the set points will vary slightly from their original setting and will require recalibration.

All switch types can be returned to Pyropress for repair and overhaul.



Before returning Switches to Pyropress, ensure that the process medium has been fully decontaminated.

## Materials of Construction

### External parts

- 316 stainless steel
- Aluminium (Aluminium switch case only)
- 304 stainless steel (Aluminium switch case only)
- Glass reinforced epoxy resin (Rigid stem only)
- Phosphor Bronze (Metallic flow only)
- Brass (Metallic flow only)

### Fasteners

- A2 & A4 stainless steels

### Wetted parts

- 316 Stainless steel (standard)
- Monel® 400 (if specified)
- Inconel (if specified)
- Hastelloy® C276 (if specified)
- Polypropylene (if specified)
- Nylon (8" types & if specified)

- 303 & 304 stainless steels (Rigid stem without thermowell only)
- Aluminium (Rigid stem with sliding gland only)
- PH15-7Mo (1" types only)
- Gunmetal (Metallic flow only)
- Brass (Metallic flow only)
- Polyvinyl chloride (Metallic flow only)
- Cotton fabric reinforced epoxy resin (Non-metallic flow only)
- Acetal (Non-metallic flow only)

### Diaphragms & pressure seals (upon request)

- Viton®
- Nitrile
- PTFE
- EPDM
- Neoprene
- Kalrez® (Temperature types)
- Silicone (Temperature types)
- Neoprene cork (Metallic flow only)

## Disposal

Ensure components that have come into contact with harmful substances are dealt with correctly.



Temperature stems contains mineral oil – do not ingest and avoid eye or skin contact. Flush eyes with copious amounts of water wash skin with soap and water. If vomiting occurs due to ingestion or persistent irritation occurs, seek medical attention.

Mineral oil should be disposed of at an authorised collection point. Do **not** discharge into drains, soil, or water.

Electrical components should be disposed in accordance with local regulations.

Most of the components are made from stainless steel or aluminium. Once the electrical components have been removed the switch can be recycled.

## Contact Details

Pyropress Limited

Bell Close

Plymouth

PL7 4JH

Tel: +44 (0)1752 333933

E-mail: [sales@pyropress.com](mailto:sales@pyropress.com)

Website: [www.pyropress.com](http://www.pyropress.com)