

Type 3320, 3321, AE3320, AE3321

Electromotive 2/2-way valve



Operating Instructions

We reserve the right to make technical changes without notice.
Technische Änderungen vorbehalten.
Sous réserve de modifications techniques.

© 2015 – 2021 Bürkert Werke GmbH & Co. KG

Operating Instructions 2105/04_EU-EN_00810525 / Original DE

Electromotive 2/2-way valve

CONTENT

1	OPERATING INSTRUCTIONS	7
1.1	Symbols.....	7
1.2	Definition of terms.....	7
2	INTENDED USE	8
3	BASIC SAFETY INSTRUCTIONS	9
4	GENERAL NOTES.....	11
4.1	Contact address.....	11
4.2	Warranty	11
4.3	Information on the Internet	11
5	PRODUCT DESCRIPTION.....	12
5.1	General description.....	12
5.2	Properties	12
6	STRUCTURE AND FUNCTION.....	14
6.1	Representation – Structure of the electromotive valve.....	15
6.2	Valve position after supply voltage failure	16
6.3	Safety position	16
6.4	Display of the device status	17
6.5	Factory settings	19
7	CONTROL ELECTRONICS.....	20
7.1	Function.....	20
7.2	Energy storage SAFEPOS energy-pack (option)	21
8	TECHNICAL DATA	24
8.1	Conformity.....	24
8.2	Standards.....	24

8.3	Approvals	24
8.4	Type label	24
8.5	Operating conditions	25
8.6	General technical data.....	28
8.7	Electrical data	28
8.8	Kv values for Type 3320 and 3321.....	30
9	INSTALLING THE VALVE	31
9.1	Safety instructions	31
9.2	Installation of devices with threaded socket connection or flange connection	31
9.3	Installation of devices with welded connections.....	32
9.4	Rotating the actuator.....	36
9.5	Holding device	37
10	ELECTRICAL INSTALLATION.....	38
10.1	Electrical installation with circular plug-in connector	38
10.2	Electrical installation with cable gland.....	41
11	START-UP	47
11.1	Safety instructions	47
11.2	Base settings.....	47
11.3	Set safety position and effective direction	47
11.4	Adjustment of position controller – execute X.TUNE	48
11.5	Set AUTOMATIC operating state.....	50
12	OPERATION.....	51
12.1	Overview: Availability of the operating elements.....	51
12.2	Display elements	52
12.3	Operating elements.....	53
12.4	büS service interface	54
12.5	SIM card – acquire and save data (option)	55
12.6	User interface of the Bürkert Communicator PC software.....	56
12.7	Establish the connection between device and Bürkert Communicator.....	57

13	BASIC FUNCTIONS.....	58
	13.1 Changing the operating state, AUTOMATIC, MANUAL.....	58
	13.2 Set safety position and effective direction	59
14	ADVANCED FUNCTIONS.....	60
	14.1 <i>X.TIME</i> – limitation of control speed	60
	14.2 <i>X.LIMIT</i> – mechanical stroke range limit.....	61
	14.3 Set LED operation mode	62
	14.4 Setting the colours for indicating valve position	63
15	MANUAL OVERRIDE OF VALVE	64
	15.1 Enable valve electrically	64
	15.2 Actuating the valve mechanically.....	65
16	OPERATING STRUCTURE AND FACTORY SETTING	67
	16.1 Operating structure of the configuration area	67
17	INDUSTRIAL ETHERNET	74
	17.1 Fieldbus gateway description	74
	17.2 Technical data Industrial Ethernet.....	76
	17.3 Projecting via fieldbus	77
	17.4 Web server	79
	17.5 Advanced functionalities	81
18	MAINTENANCE, TROUBLESHOOTING.....	83
	18.1 Safety instructions	83
	18.2 Maintenance.....	83
	18.3 Troubleshooting	85
19	CANopen	88
	19.1 Projecting via fieldbus	88
	19.2 CANopen network configuration.....	88
20	büS.....	88

20.1	Cabling of bÜS networks	88
20.2	Configuration of bÜS networks.....	88
21	CLEANING	89
22	ACCESSORIES, REPLACEMENT PARTS.....	90
22.1	Communication software.....	90
22.2	Spare parts.....	91
22.3	Assembly tools.....	92
23	DISASSEMBLY	93
23.1	Safety instructions	93
24	PACKAGING AND TRANSPORT	94
25	STORAGE	94
26	DISPOSAL	94

1 OPERATING INSTRUCTIONS

The operating instructions describe the entire life cycle of the device. Keep these instructions in a location which is easily accessible to every user and make them available to every new owner of the device.

Important safety information!

Carefully read through the operating instructions. Study in particular the chapters entitled *Basic safety instructions* and *Intended use*.

- ▶ The operating instructions must be read and understood.

1.1 Symbols



DANGER!

Warns of an immediate danger.

- ▶ Failure to observe these instructions will result in death or serious injuries.



WARNING!

Warns of a potentially hazardous situation.

- ▶ Failure to observe these instructions may result in serious injuries or death.



CAUTION!

Warns of a potential danger.

- ▶ Failure to observe these instructions may result in moderate or minor injuries.

NOTE!

Warns of damage.

- Failure to observe the warning may result in damage to the device or the equipment.



Indicates important additional information, tips and recommendations.



Refers to information in these operating instructions or in other documentation.

- ▶ Designates instructions to avoid danger.
- Designates a procedure that you must carry out.
- ✓ designates a result.

1.2 Definition of terms

- The term “Device” used in these instructions applies to all valve types described in these instructions.
Type 3320, electromotive 2/2-way angle seat valve
Type 3321, electromotive 2/2-way globe valve
- The abbreviation “Ex” used in these instructions stands for “potentially explosive”.
- The term “bÜS” (Bürkert system bÜS) used in this manual stands for the communication bÜS developed by Bürkert, based on the CANopen protocol.
- In these instructions, the unit bar stands for relative pressure. The absolute pressure is stated separately in bar(abs).

2 INTENDED USE

Improper use of the electromotive 2/2-way Type 3320 and 3321 valve may be dangerous for people, nearby equipment and the environment.

The electromotive 2/2-way Type 3320 and 3321 valve is designed to control the flow of liquid and gaseous media.

- ▶ Standard devices must not be used in the potentially explosive area. They do not possess the separate “Ex” type label denoting the approval for use in potentially explosive environments.
- ▶ If the position of the valve has a bearing on safety concerns in the event of a power failure: Only use devices that have a SAFEPOS energy-pack (optional energy pack).
- ▶ When using the device, observe the authorised data, operating conditions and deployment conditions specified in the contract documents and in the operating instructions.
- ▶ Protect device from harmful environmental influences! (e.g. radiation, air humidity, fumes, etc.) For any matters requiring clarification, contact the relevant sales department.

Use the device

- ▶ Use only in conjunction with third-party devices and components recommended or approved by Bürkert.
- ▶ Only use the device when it is in perfect condition; always ensure proper storage, transportation, installation and operation.
- ▶ only as intended.

3 BASIC SAFETY INSTRUCTIONS

These safety instructions do not take into account any unforeseen circumstances and events which occur during installation, operation and maintenance. The operator is responsible for observing the location-specific safety regulations, also with reference to personnel.



Risk of injury from high pressure.

- ▶ Before working on the device or system, switch off the pressure and vent or empty the lines.

Danger of burns and risk of fire.

Following an extended duty cycle or as a result of a hot medium, the surface of the device may become hot.

- ▶ Only touch the device when wearing protective gloves.
- ▶ Keep the device away from highly flammable substances and media.

Danger due to loud noises.

- ▶ Depending on the usage conditions, the device may generate loud noises. Detailed information on the probability of loud noises is available from the respective sales department.
- ▶ Wear hearing protection when in the vicinity of the device.

Discharge of medium if packing gland worn.

- ▶ Relief bore must be regularly inspected for any medium leakages.
- ▶ If medium is leaking from the relief bore, the packing gland must be replaced (see chapter “Maintenance”).
- ▶ If the medium is hazardous, secure the area around the leakage to prevent risks.

Risk of crushing by mechanically powered parts.

- ▶ Installation work on the swivel plate, diaphragm and valve body must only be performed while electrically isolated.
For devices with SAFEPOS energy-packs: Ensure that the SAFEPOS energy-pack is fully discharged. Wait until the LED ring is no longer lit and ensure that the LED status is not in “LED off” **mode**.
- ▶ Do not reach into the openings of the valve body.

Risk of uncontrolled process in the event of a power failure.

For devices without the optional SAFEPOS energy-pack, the valve will not stop in a defined position in the event of a power failure.

- ▶ If the position of the valve has a bearing on safety concerns in the event of a power failure: Only use devices that have a SAFEPOS energy-pack (optional energy pack).
- ▶ Select a valve position that is safe in respect of the process using the DIP switch.

General hazardous situations.

To prevent injury, ensure that:

- ▶ In potentially explosive environments, the device must only be used in accordance with the specifications on the separate Ex-type label.
- ▶ The additional information and safety instructions relating to potentially explosive atmospheres enclosed with the device or the separate operating instructions relating to potentially explosive atmospheres must be heeded when using the device.
- ▶ In potentially explosive atmospheres, only use devices with a separate type label for use in such atmospheres.
- ▶ Feed only those media listed in chapter [“8 Technical data”](#) into the medium ports.
- ▶ Do not make any internal or external changes to the device and do not subject it to mechanical stress.
- ▶ Transport, install and dismantle a heavy device only with the aid of a second person and using suitable equipment.
- ▶ Secure to prevent unintentional operation.
- ▶ Only trained technicians carry out installation and maintenance work.
- ▶ Following an interruption in the power supply, ensure that the process is restarted in a controlled manner. Observe the sequence.
 1. Connect supply voltage.
 2. Charge the device with medium.
- ▶ Observe general engineering standards & rules.
- ▶ The valves must be installed according to the regulations applicable in the country of use.

NOTE!

Electrostatically sensitive components and assemblies.

The device contains electronic components that are susceptible to the effects of electrostatic discharging (ESD). Components that come into contact with electrostatically charged persons or objects are at risk. In the worst-case scenario, they will be destroyed immediately or will fail after start-up.

- Meet the requirements specified by EN 61340-5-1 to minimise or avoid the possibility of damage caused by sudden electrostatic discharge.
- Do not touch electronic components when the supply voltage is connected.

4 GENERAL NOTES

4.1 Contact address

Germany

Bürkert Fluid Control Systems
Sales Center
Christian-Bürkert-Str. 13-17
D-74653 Ingelfingen
Tel. + 49 (0) 7940 - 10-91 111
Fax + 49 (0) 7940 - 10-91 448
E-mail: info@burkert.com

International

The contact addresses can be found on the back pages of the printed operating instructions.

Also on the Internet at:

country.burkert.com

4.2 Warranty

A precondition for the warranty is that the device is used as intended and that the specified usage conditions are taken into account.

4.3 Information on the Internet

Operating instructions and data sheets for Types 3320 and 3321 can be found on the Internet at:

country.burkert.com

5 PRODUCT DESCRIPTION

5.1 General description

The 2/2-way electromotive valve Type 3320 and 3321 is suitable for liquid and gaseous media.

This may be neutral gas, water, alcohol, oil, fuel, hydraulic fluid, salt solution, caustic soda, organic solvent or vapour.

The 2/2-way valve has an electromotive linear actuator with the actuating electronics assembly, which is actuated either via binary signals or (digitally) via a fieldbus. The electromotive linear actuator is set up such that it is optimally effective. At the same time, when idling without power, it also keeps the valve sealed even under the maximum specified operating pressure.

The device can also be equipped with the energy storage system (SAFEPOS energy-pack). In the event of a supply voltage failure, the energy storage system supplies the actuator with the energy required to move the valve to the desired position, which can be set in the menu.

The valve position can be manually changed in two ways.

1. Electrical manual override: used if supply voltage is present.
2. Mechanical manual override: must only be used if there is no supply voltage present.

The device can be operated with 2 capacitive buttons and 4 DIP switches. It is also always possible to set the device with the bÜS service interface and by using the PC software Bürkert Communicator. The USB bÜS interface set, available as an accessory, is required for configuration with Bürkert Communicator.

5.2 Properties

- High seal tightness due to self-adjusting packing gland.
- Devices with PTFE and PEEK material are kept sealed without power.
- High flow rate values due to the stainless steel valve body that aids in flow.
- Mechanical position indicator shows the valve position even in the event of a supply voltage failure.
- 360° LED light ring for displaying device states, valve end positions and operating state.
- No electrical energy is required to hold the valve position even under maximum operating pressure, except for basic consumption for the control unit.
- Easy and quick replacement of the swivel plate.
- Valve actuator can rotate 360°.
- Integrated control unit.
- High seat tightness due to swivel plate.
- Contact-free, high-resolution and wear-free position sensor.
- The actuator housing consists of a robust and heat-dissipating aluminium body. The coating is resistant to common detergents. The plastics used for the actuator housing are also detergent-resistant.

5.2.1 Variants (valve sizes and actuator sizes)

Angle seat valve Type 3320 and globe valve Type 3321:

Available actuator size in nominal force [N]							
DN connection (valve body)		Seat size valve					
[DN]	[NPS]	15	20	25	32	40	50
15	1/2	1300	-	-	-	-	-
20	3/4	-	1300	-	-	-	-
25	1	-	-	1300	-	-	-
32	1 1/4	-	-	-	1300, 2500	-	-
40	1 1/2	-	-	-	-	1300, 2500	-
50	2	-	-	-	-	-	1300, 2500

Table 1: Variants for Types 3320 and 3321

5.2.2 Options

- Energy storage system (SAFEPOS energy-pack) for reaching safety position.
The safety position that the valve is supposed to take in the event of a supply voltage failure is specified with the DIP switch.
- SIM card for saving and transmitting device-specific values and settings.

6 STRUCTURE AND FUNCTION

The electromotive valve consists of an electromotive linear actuator, a swivel plate and a 2/2 way globe valve body or a 2/2 way angle seat valve body.

The control electronics and “SAFEPOS energy-pack” are housed in the side of the linear actuator.

The control electronics consist of the microprocessor-controlled electronic mechanism and the position sensor.

Actuation occurs via binary signals (analogue) or fieldbus (digital).

The electromotive valve is designed with the three-wire technique. Operation is performed with 2 buttons and 4 DIP switches.

The electromotive linear actuator consists of a brushless direct current motor, a gear and a threaded spindle. The valve spindle connected to the threaded spindle transfers the force to the swivel plate.

- The linear actuator is designed such that it does not require any electrical energy to hold the valve position, i.e. when idling only the control electronics consume energy.
- The stainless steel valve body aids in flow and facilitates high flow rates.
- The self-adjusting packing gland guarantees a high degree of tightness. The swivel plate is connected to the actuator spindle by a bolt, and is thus easy to replace.
- The actuator housing consists of a robust and heat-dissipating aluminium body with a detergent-resistant coating. The plastics used are also detergent-resistant.

Valve seat:

The valve seat is always closed against the medium flow. The flow direction must thus be such that the flow reaches the valve below the seat.

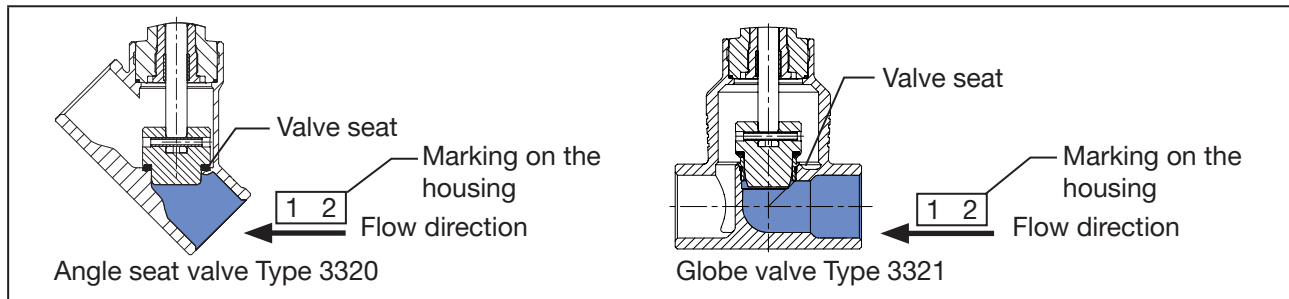

Image 1: Flow direction below seat, flow direction

Fluidic connections:

- The threaded socket connection, welded connection or clamp connection are available for all valve bodies.
- The valve body with flange connection is also available for globe valve Type 3321.

6.1 Representation – Structure of the electromotive valve

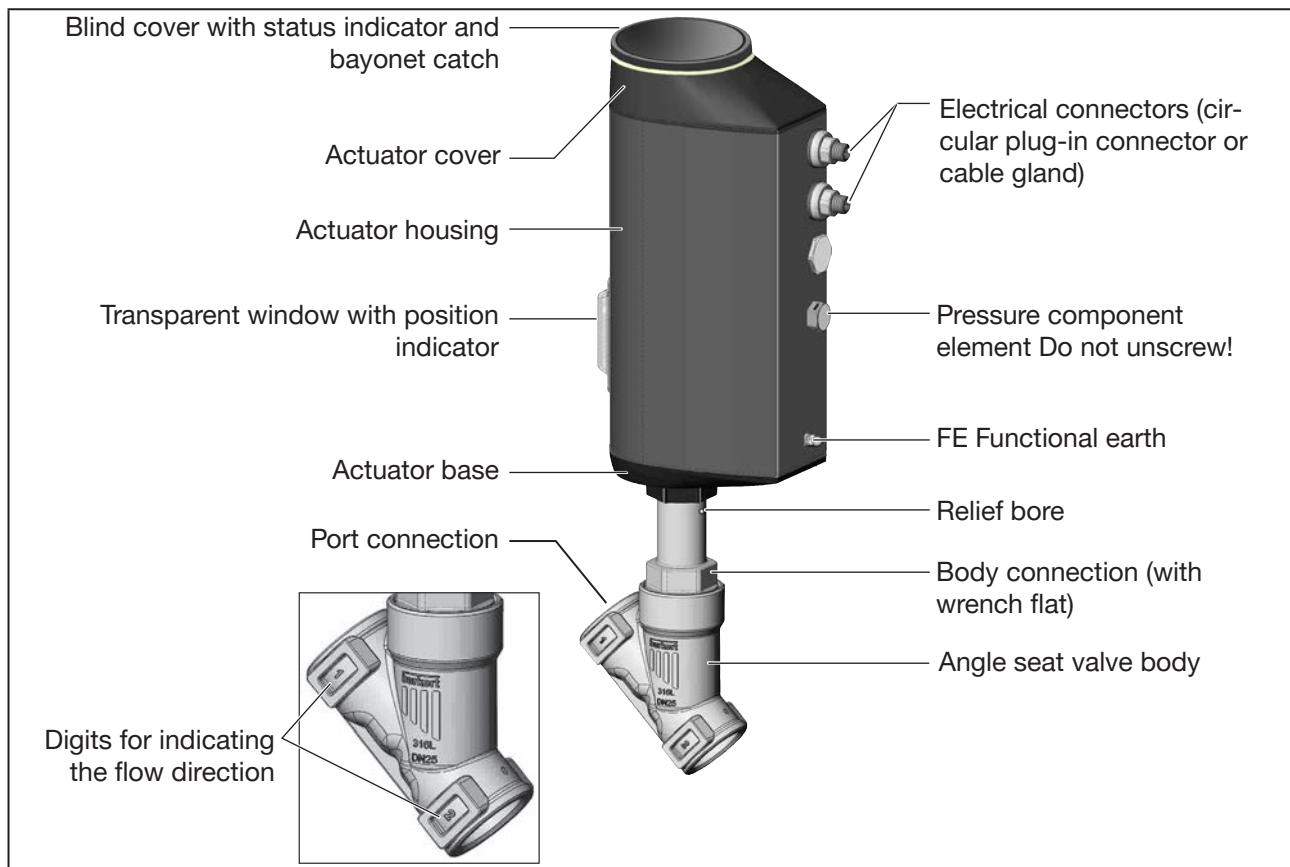

Image 2: Assembly, electromotive angle seat valve Type 3320

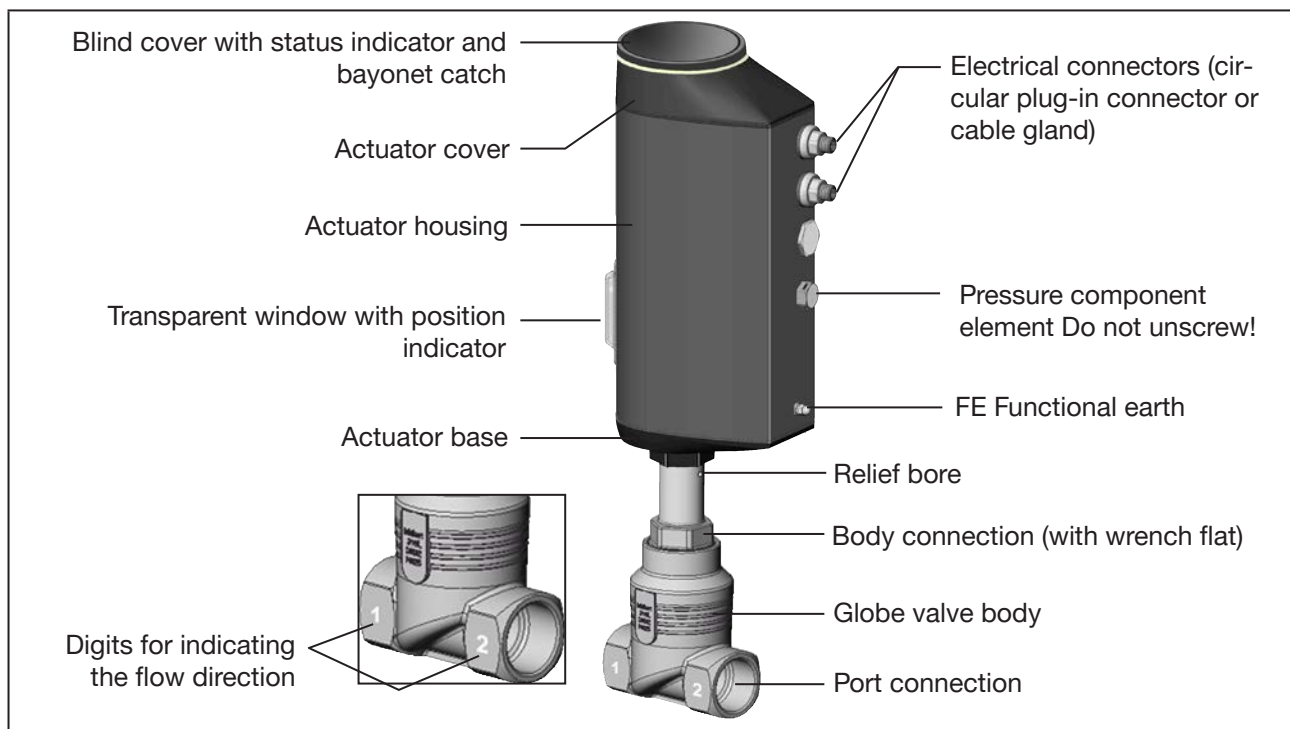

Image 3: Assembly, electromotive globe valve Type 3321

6.2 Valve position after supply voltage failure

Valve position for devices without the SAFEPOS energy-pack energy storage:

If the electromotive actuator idles upon a supply voltage failure, the valve remains in the last position that it was in.

If the supply voltage fails while the actuator is changing the valve position, the valve remains in an undefined position. The flywheel mass of the actuator and the operating pressure continue to influence the valve spindle until it finally idles.

Valve position for devices with the SAFEPOS energy-pack energy storage:

The valve assumes the safety position defined in the SAFEPOS menu.



For a description of the SAFEPOS energy-pack energy storage system, see chapter [“7.2 Energy storage SAFEPOS energy-pack \(option\)”](#) on page 21

6.3 Safety position

The DIP switch defines the safety position that the valve assumes in the following scenarios:

- Internal error
- Supply voltage failure (optional)
This function is only available for devices that have the optional SAFEPOS energy-pack energy storage accessory.

The following safety positions are available to choose from for SAFEPOS:

- Close = valve closed
- Open = valve opened
- Inactive = valve remains in an undefined position in the event of a supply voltage failure.

6.4 Display of the device status

The device status is displayed on the LED light ring. Various LED modes can be set to display device status and valve position:

- Valve mode
- Valve mode + warnings (factory pre-set)
- NAMUR operation mode



* The description for setting the LED mode can be found in chapter [“14.3 Set LED operation mode”](#) on page 62.

6.4.1 Valve mode

The valve position and device status “Failure” are displayed in the valve mode.



Notifications on device statuses “Out of specification”, “Maintenance required” and “Function check” are not displayed in the valve mode.
The factory-set colours for displaying the valve positions “open” and “closed” can be switched. For a description see chapter [“14.4 Setting the colours for indicating valve position”](#).

Displays in valve mode:

If device status “Normal”: Continuously lit in the colour of the valve position.

For device status “Failure”: Alternating flashing between red and the valve position colour.

Valve position	Colour for valve position	Colour for device status “Failure”
open	yellow	red
in between	white	
closed	green	

Table 2: Display of device status in valve mode

6.4.2 Valve mode + warnings

In this operation mode, the valve position and device statuses “Failure”, “Out of specification”, “Maintenance required” and “Function check” are displayed.

If several device statuses exist simultaneously, the device status with the highest priority is displayed. The priority is based on the severity of the deviation from standard operation (red = failure = highest priority).

Displays in valve mode + warnings:

For device status “Normal”: Continuously lit in the colour of the valve position.

If device status is not “Normal”: Flashes alternately with the colours for the valve position and the device status.

Valve position	Colour for valve position	Colour for device status			
		Failure	Outside of specification	Maintenance required	Function check
open	yellow	red	yellow	Blue	orange
in between	white				
closed	green				

Table 3: Display of device status in valve mode + warnings

6.4.3 NAMUR operation mode

In NAMUR mode the LED light ring lights up in the colour specified for the device status as per NAMUR NE 107.

If several device statuses exist simultaneously, the device status with the highest priority is displayed. The priority is based on the severity of the deviation from standard operation (red = failure = highest priority).

Indicators in NAMUR operation mode:

Status LED in line with NE 107, issue 2006-06-12			
Colour	Colour code	Description	Meaning
red	5	Failure, error or fault	Due to a malfunction in the device or its peripherals, closed-loop control mode is not possible.
orange	4	Function check	Work is being carried out on the device, which means that closed-loop control mode is temporarily not possible.
yellow	3	Outside of specification	The environment conditions or process conditions for the device are not within the specified range. Internal device diagnostics indicate problems within the device or with the process properties.
Blue	2	Maintenance required	The device is in closed-loop control mode, but function will soon be restricted. → Perform device maintenance.
green	1	Diagnostics active	Device is in error-free operation. Status changes are highlighted in colour. Messages are sent via any fieldbus that may be connected.
white	0	Diagnostics inactive	Device is switched on. Status changes are not displayed. Messages are not transferred via a fieldbus that may be connected.

Table 4: Indication of the device status in NAMUR operation mode



* A detailed fault description can be found in chapter [“18.3 Troubleshooting”](#) on page 85.

6.4.4 Flashing of the LED light ring

Quick flashing of the LED light ring indicates that it a connection with the PC software Bürkert Communicator has been established.

6.4.5 Notifications on device status

Notifications on device statuses and errors are entered into the logbook. Chapter [“18 Maintenance, troubleshooting”](#) contains the most common notifications and the measures that they require.

Notifications on device status “Function check”

The notifications are presented when operation is interrupted by work on the device.

Notifications on device status “Function check”
MANUAL operating state active
X.TUNE active
Signal generator active

Table 5: Notifications on device status “Function check”

6.5 Factory settings



Operating state:

Devices in their factory default state have their operating state preset to MANUAL.

The pre-set factory settings can be found in chapter [“16 Operating structure and factory setting”](#).

The factory settings are depicted in blue in the operating structure to the right of the menu.

7 CONTROL ELECTRONICS

7.1 Function

The actuator (stroke) position is controlled by the digital input. The position is specified either by an external signal (analogue) or via a fieldbus (digital).

The position sensor records the current position of the electrical linear actuator and from this creates an end position signal via the digital outputs.

Technical characteristics:

- **Position sensor**
contact-free, high-resolution and wear-free.
- **Microprocessor-controlled electronics assembly**
for signal processing, control and motor control.
- **Electrical interfaces**
(circular plug-in connector or cable gland)

7.1.1 Interfaces

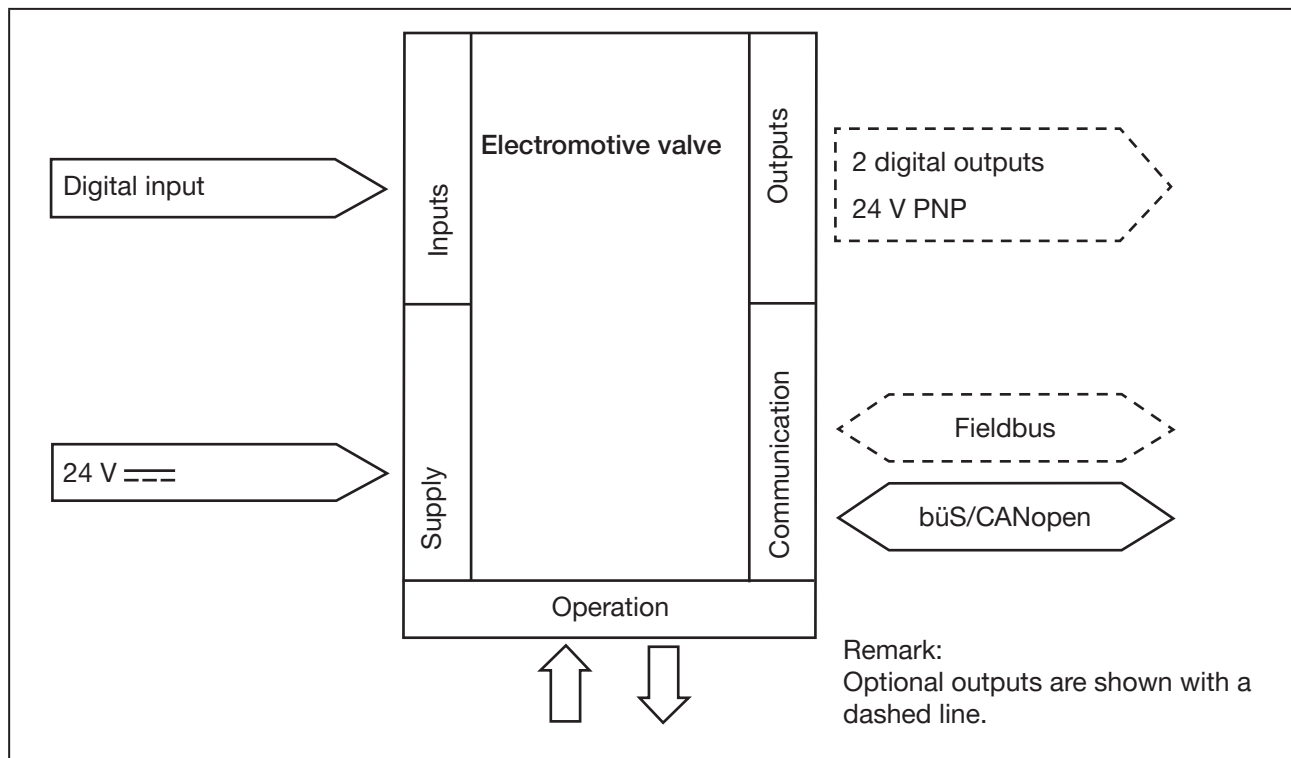

Image 4: Interfaces of the electromotive valve



The electromotive valve is designed with the three-wire technique, i.e. the electrical supply (24 V ===) is separate from the position signal of the digital input.

7.1.2 Functional diagram

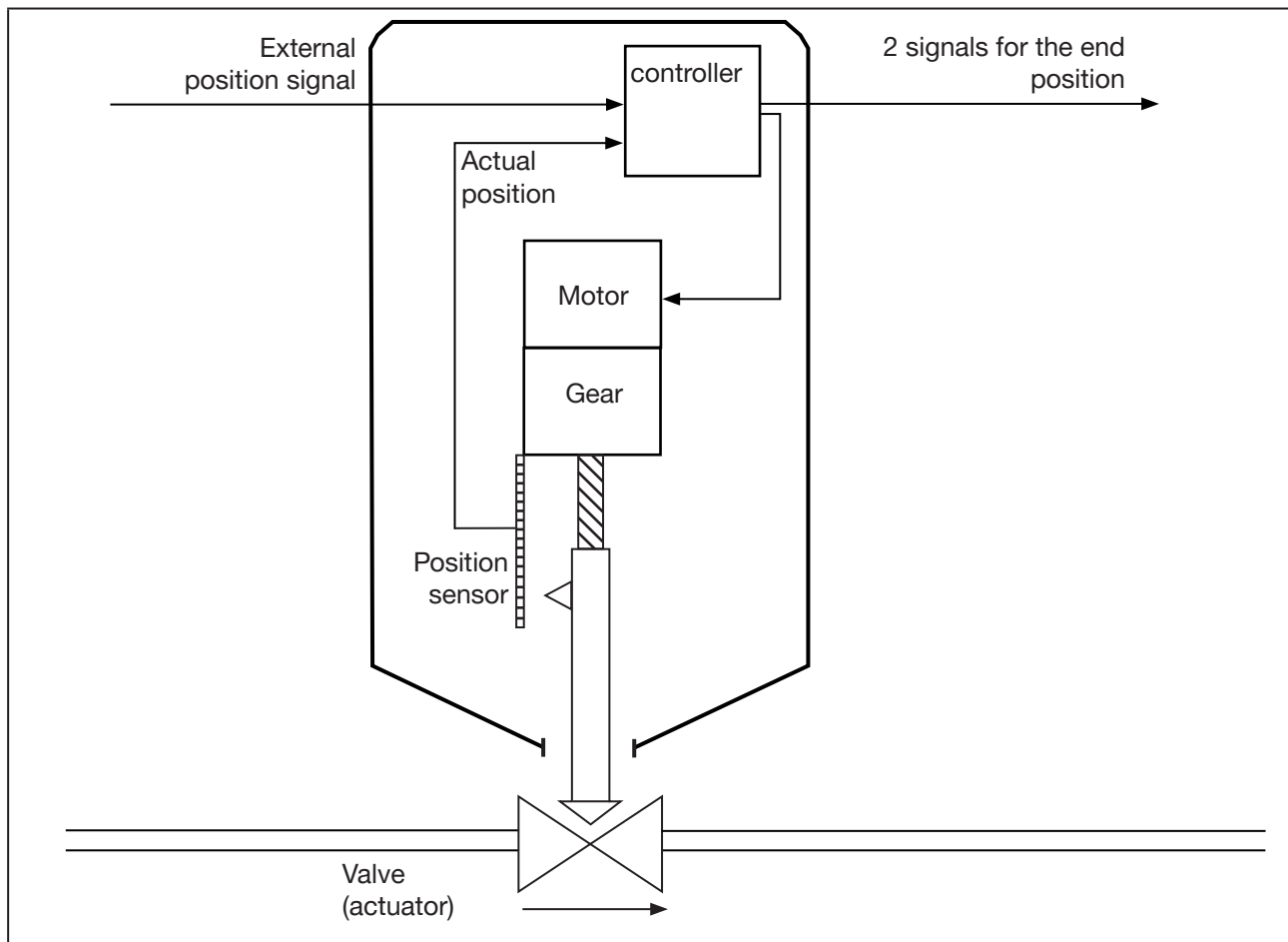

Image 5: Functional diagram

7.2 Energy storage SAFEPOS energy-pack (option)

The device can also be equipped with the energy storage system (SAFEPOS energy-pack). In the event of a supply voltage failure, the energy storage system supplies the actuator with the energy required to move the valve to the safety position.

The safety position is set using the DIP switch.

After a maximum of 100 seconds (depending on operating conditions), the energy storage is fully charged and ready for operation

7.2.1 Service life

Service life: up to 10 years (depending on operating conditions).

The service life of 5 years was calculated based on the following conditions:

Ambient temperature	30 °C
Medium temperature	165 °C
Duty cycle	100%
Operating pressure	5 bar
DN	DN32

NOTE!

The energy storage system SAFEPOS energy-pack is a wearing part. The service life figures are approximate values that cannot be guaranteed.

7.2.2 Notifications on the state of the SAFEPOS energy-pack

The device issues a warning:

The remaining service life of the energy pack is around 25%! The energy pack needs to be replaced soon.

- ▶  The SAFEPOS energy-pack must be promptly replaced before the end of its service life.

The device issues an error alert and assumes the safety position:

The SAFEPOS energy-pack was not promptly replaced before issuance of the warning. The storage capacity is so low that assumption of the safety position can no longer be guaranteed.

7.2.3 Replacing the SAFEPOS energy-pack



CAUTION!

Risk of injury due to electrical voltage.

- ▶ Turn off the supply voltage before removing the SAFEPOS energy-pack.
- ▶ Ensure that the SAFEPOS energy-pack is fully discharged. Wait until the LED ring is no longer lit and ensure that the LED status is not in “LED off” **mode** (see chapter “14.3 Set LED operation mode”).

The SAFEPOS energy-pack energy storage system is located in the actuator housing. Remove the following parts from the actuator for replacement:



Devices with ATEX approval or IECEx approval are secured with a magnetic lock.

The removal of the cover is described in the supplementary instructions for the electromotive control valves with ATEX approval and IECEx approval.

1. Blind cover
2. LED & storage module
3. Actuator cover

The process for removing these parts is described in detail in chapter “10.2.2 Access to connection terminals” on page 41.

Removing SAFEPOS energy-pack:

- Loosen the safety screw (hexalobular-internal screw T10).
- Completely pull the SAFEPOS energy-pack out from the clamp.

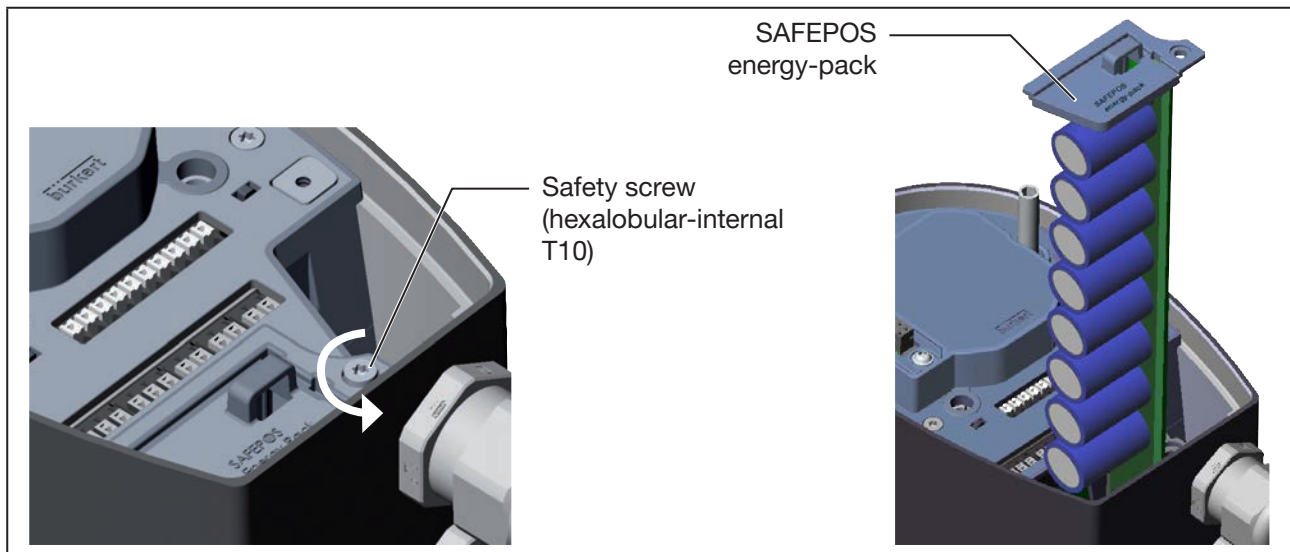

Image 6: Removing SAFEPOS energy-pack

Inserting new SAFEPOS energy-pack:

- Remove the SAFEPOS energy-pack from the transport packaging.
- Insert the SAFEPOS energy-pack into the two guide grooves on the side and push it in until it stops.

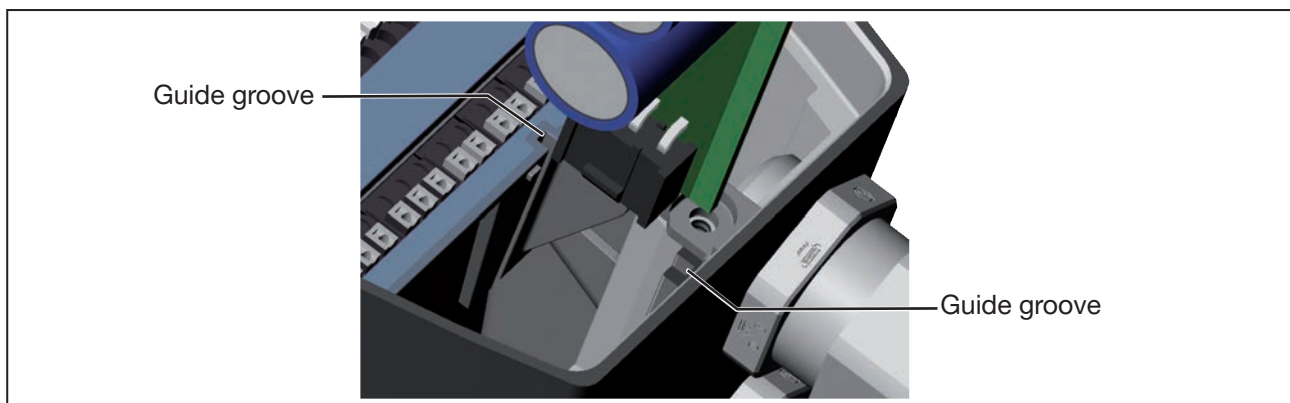

Image 7: Inserting SAFEPOS energy-pack

- Apply the safety screw (hexalobular-internal screw T10).
- Connect supply voltage.

8 TECHNICAL DATA



The following product-specific information is provided on the type label:

- Voltage [V] (tolerance $\pm 10\%$) and current type
- Seal material of the valve body
- Fieldbus standard
- Flow capacity
- Actuator size
- Maximum permitted operating pressure
- Flow direction

8.1 Conformity

The electromotive Type 3320, and 3321 valves are compliant with the EU directives in relation to the EU Declaration of Conformity (if applicable).

8.2 Standards

The applied standards, which are used to demonstrate conformity with the directives, are listed in the EU type examination certificate and/or the EU Declaration of Conformity (if applicable).

8.3 Approvals

The product is cULus listed. Refer to chapter “8.7 Electrical data” for information on use in UL environments.

8.4 Type label

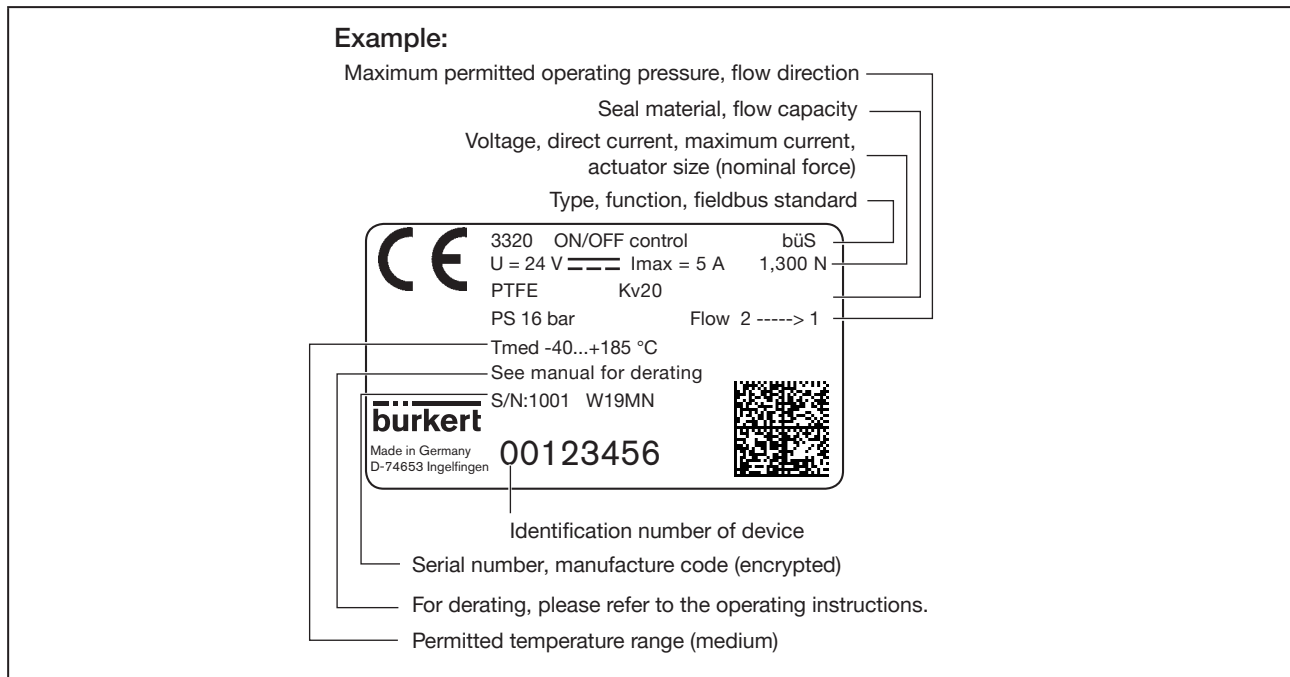

Image 8: Description of the type label (example)

8.4.1 Additional type label for UL approval (example)

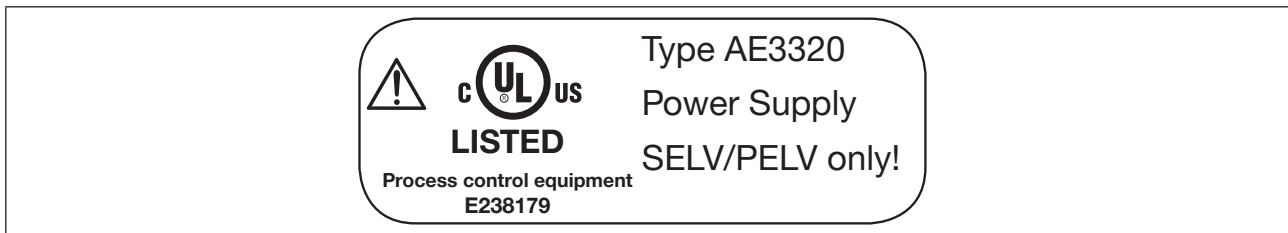

Image 9: Additional type label for UL approval

8.5 Operating conditions



The product-specific information on the type label must be heeded when operating the device.



WARNING!

Loss of function if operated below or above permitted temperature range.

- ▶ Never expose the device to direct sunlight in outdoor areas.
- ▶ Do not operate above or below the permitted ambient temperature range.



WARNING!

Reduced sealing function if operating pressure too high.

Because the valve seat is closed against the medium flow, an excessive operating pressure may cause the valve seat to not close tightly.

- ▶ The operating pressure must not exceed the maximum value specified on the type label.

Maximum permitted operating pressure:	see type label, depending on usage limits of the armature (derating operating pressure)
Media:	Neutral gases and steam. Liquid media: Water, alcohol, oil, fuel, hydraulic fluid, salt solution, caustic soda, organic solvent.
Degree of protection :	(verified by Bürkert/not evaluated by UL) IP65 in accordance with IEC 529, EN 60529, (IP67 on demand). NEMA 250 4x (not guaranteed for installation position: actuator facing downwards).
Flow direction:	indicated on the type label with an arrow and the digits 1 and 2. The 1 and 2 are also on the valve body for identification. The flow direction is below the seat with flow from port 2 to port 1.
Altitude:	up to 2,000 m above sea level

8.5.1 Permitted temperature ranges

Minimum temperatures	Environment:	-25 °C
	Medium:	-10 °C (-40 °C on request)
Maximum temperatures	Environment:	depends on the medium temperature, see subsequent temperature diagram.
	Medium:	depends on the ambient temperature; see temperature diagram below, as well as usage limits of the valve (derating operating pressure). For devices with PTFE valve seat seal, max. +130 °C absolute. For devices with PEEK valve seat seal, max. +185 °C (+230 °C on request) absolute.

Temperature diagram

The maximum permitted temperature for the environment and medium are dependent on one another. The permitted maximum temperatures of the device variants can be determined using the characteristics of the temperature diagram.

The values are calculated under the following maximum operating conditions: DN DN32 at 100% duty cycle with 16 bar operating pressure.

Individual reviews may be performed under different operating conditions. For this, please contact your Bürkert branch office.

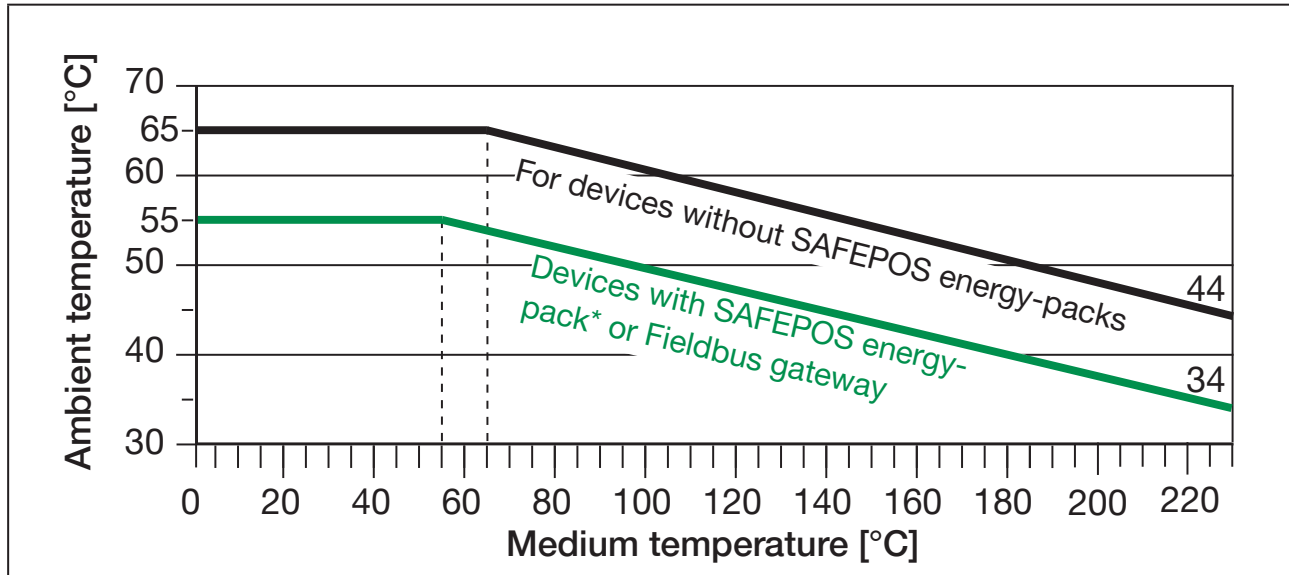

Image 10: Temperature diagram



*The service life of the SAFEPOS energy-pack is dependent on the medium temperature and ambient temperature. For a description see [“7.2 Energy storage SAFEPOS energy-pack \(option\)”](#)

Derating pressure and temperature ranges

Usage limits of the valve (derating operating pressure)

Medium temperature	Operating pressure
-10 – +50 °C	25 bar
100 °C	24.5 bar
150 °C	22.4 bar
200 °C	20.3 bar
230 °C	19 bar

Table 6: Derating the operating pressure as per DIN EN 12516-1/PN25

Medium temperature	Operating pressure
-29 – +38 °C	19 bar
50 °C	18.4 bar
100 °C	16.2 bar
150 °C	14.8 bar
200 °C	13.7 bar
230 °C	12.7 bar

Table 7: Derating the operating pressure as per ASME B16.5/ASME B16.34 Cl.150

Medium temperature	Operating pressure
-10 – +50 °C	14 bar
100 °C	14 bar
150 °C	13.4 bar
200 °C	12.4 bar
230 °C	11.7 bar

Table 8: Derating the operating pressure as per JIS B 2220 10K

8.6 General technical data

Dimensions:	see data sheet	
Weight:	see data sheet	
Materials:	Actuator:	PPS and aluminium, powder-coated
	valve body:	316L
	body connection:	316L/1.4401
	spindle:	1.4401/1.4404
	spindle guide:	PEEK
	packing gland	PTFE V-rings with spring compensation (carbon-filled PTFE)
Seal material:	Actuator housing sealing element:	EPDM
	valve seat seal:	see type label
Fluid connection:	Possible connection types: Threaded socket connection G ½...G 2 (NPT, RC on request) Welded connection as per EN ISO 1127 (ISO 4200), DIN 11850 series 2	
	Additionally for Type 3321 globe valves: Flange connection as per DIN 2634, ANSI B16.5 class 150, JIS 10K Clamp connection as per ISO 2852, DIN 32676, ASME BPE, BS 4825	
	Other connections on request	
Electrical connection:	with terminal connectors or circular plug-in connectors	
Installation position:	any, preferably actuator face up	
Sound pressure level:	<70 dB (A), may be higher depending on the operating conditions.	
Kv value:	see type label or chapter “8.8”	

8.7 Electrical data



WARNING!

Electrical shock.

Protection class III is only guaranteed when using an SELV or PELV power supply unit.

Protection class:	3 according to DIN EN 61140 (VDE 0140)	
Electrical connections:	Terminal strip with cable gland, 2x M20 or 2 circular plug-in connectors M12, 5-pin und 8-pin	
Operating voltage:	24 V $\overline{=}$ ± 10% max. residual ripple 10%	
Operating current [A]*:	max. 3 A (at 25 °C) including actuator at max. load and charging current of the optional SAFEPOS energy-pack (charging current approx. 1 A) for the design of the power supply unit	
Standby consumption (electronics assembly without actuator) [W] ¹⁾		
Standard consumption:	minimum	2 W
	typically	3 W
SAFEPOS energy-pack:	0.5 W	
Fieldbus gateway:	1 W	

Energy consumption of actuator for 1 cycle [Ws]*
 min. 36 Ws
 max. 140 Ws
 (depending on device variant and operating conditions)



The operating current can be reduced by the following measures, if necessary

1. For devices with the SAFEPOS energy-pack energy storage:
 Setting the function "Control if ready" reduces the max. operating current by 1 A.

Setting in the configuration area **Position controller** → **Parameter** → **SAFEPOS** → **ENERGY-PACK** → **FUNCTION** → **Control if ready**.

2. Reducing the control speed X.TIME.

Setting: Setting in the configuration area **Position controller** → **Parameter** → **ADD** → **FUNCTION** → **Activate X.TIME** → **X.TIME** → **Opening time** → **Closing time**.

Service life of energy storage
 SAFEPOS energy-pack:

Charging time: maximum 100 seconds (dependent on operating conditions)

Service life: up to 10 years (depending on operating conditions).

The service life of 5 years was calculated based on the following conditions:

Ambient temperature	30 °C
medium temperature	165 °C
duty cycle	100%
operating pressure	5 bar
DN	DN32

NOTE!

Consider voltage drop on power supply cable.

Example: with a cable cross-section of 0.34 mm² the copper cable must not be more than 8 metres in length.

Digital outputs (optional)

Current limit: 100 mA

Digital inputs:

for position signal

0–5 V = log "0", 10–30 V = log "1"

inverted input inverted accordingly (input current < 6 mA)

Communication interface: Connection to PC using USB bÜS interface set

Communication software: Bürkert Communicator



The digital outputs are not galvanically isolated from the operating voltage. They refer to the operating voltage GND.

Current limit: output voltage is reduced in the event of overload.

* All values relate to a supply voltage of 24 V $\overline{\text{---}}$ at 25 °C.

Note: At minimum ambient and medium temperatures, the operating current can be up to 5 A (incl. 1 A charging current for the optional SAFEPOS energy-pack).

8.8 Kv values for Type 3320 and 3321



Kv value water (m³/h)

Flow coefficient: Measurement at +20 °C, 1 bar pressure at the valve inlet and free outlet.

8.8.1 Kv values for angle seat valve Type 3320

Seat size	Kv value water [m ³ /h] for flow direction below seat	Cv value [gal/min] for flow direction below seat
15	5	5.8
20	11	12.7
25	18	20.8
32	31	35.8
40	42	48.6
50	62	71.7

Table 9: Kv values for Type 3320

8.8.2 Kv values for globe valve Type 3321

Seat size	Kv value water [m ³ /h] for flow direction below seat	Cv value [gal/min] for flow direction below seat
15	4.7	5.4
20	8.1	9.4
25	13	15.0
32	18	20.9
40	31	35.8
50	45	52.0

Table 10: Kv values for Type 3321

9 INSTALLING THE VALVE

9.1 Safety instructions



WARNING!

Risk of injury due to improper installation.

- ▶ Installation may be carried out by trained technicians only and with the appropriate tools.
- ▶ Secure the system to prevent unintentional activation.
- ▶ After installation, ensure that the process is restarted in a controlled manner. Observe the sequence.
 1. Connect supply voltage.
 2. Charge the device with medium.



CAUTION!

Risk of injury due to heavy device.

During transportation or installation work, the device may fall down and cause injuries.

- ▶ Transport, install and remove heavy device with the aid of a second person only.
- ▶ Use suitable tools.

9.2 Installation of devices with threaded socket connection or flange connection

NOTE!

Damage to valve body, seat seal or diaphragm.

- ▶ To prevent damage, the device must be in MANUAL operating state during installation. Devices in their factory default state already have their operating state set to MANUAL.

NOTE!

The following must be heeded when installing the device in the system.

The device and relief bore must be accessible for inspections and maintenance work.

9.2.1 Mounting conditions

Installation position: arbitrary, ideally with actuator facing upwards.

Flow direction: indicated on the type label with an arrow and the digits 1 and 2. The 1 and 2 are also on the valve body for identification. The flow direction is below the seat with flow from port 2 to port 1.

Pipelines: ensure that pipelines are in alignment.

Filter: required for devices with approval as per EN 161. According to EN 161 "Automatic shut-off valves for gas burners and gas appliances", a dirt trap, which prevents the penetration of a 1 mm test pin, must be installed upstream of the valve in the pipeline.

Preparation: Clear impurities from pipelines (seal material, metal chips, etc.).

9.2.2 Installation



DANGER!

Risk of injury from high pressure.

- ▶ Before working on the system, switch off the pressure and vent or empty the lines.



WARNING!

Risk of crushing by mechanically powered parts.

- ▶ Do not reach into the openings of the valve body.

→ Connect valve body to pipeline.

Ensure that there is no voltage present and minimal vibration during installation.



Holding device

To protect the valve actuator from damage resulting from forces and vibrations, a holding device is recommended. This is available as an accessory. See chapter [“22 Accessories, replacement parts”](#).

9.3 Installation of devices with welded connections

NOTE!

Damage to valve body, seat seal or diaphragm.

- ▶ To prevent damage, the device must be in MANUAL operating state during installation.

Devices in their factory default state already have their operating state set to MANUAL.

NOTE!

The following must be heeded when installing the device in the system.

The device and relief bore must be accessible for inspections and maintenance work.

The device must not be welded into the pipeline while the actuator is still installed. The installation is divided into the following steps:

1. Prepare the actuator disassembly.
2. Disassemble actuator.
3. Weld the valve body into the pipeline.
4. Mounting actuator on the valve body.

9.3.1 Prepare the actuator disassembly

NOTE!

Damage to valve body, seat seal or diaphragm.

To avoid damage, the valve must be open when the actuator is disassembled.

→ If the valve is closed: Open the valve with the mechanical manual override. See chapter [“15.2 Actuating the valve mechanically”](#) on page 65.

! WARNING!

Risk of crushing by mechanically powered parts.

- ▶ Switch off the supply voltage.
- ▶ For devices with SAFEPOS energy-packs: Ensure that the SAFEPOS energy-pack is fully discharged. Wait until the LED ring is no longer lit and ensure that the LED status is not in **“LED off”** mode.
- ▶ Do not reach into the openings of the valve body.

9.3.2 Disassemble actuator

→ Clamp valve body into a holding device.

→ Place on the body connection with a suitable open-end wrench.

⚠ Do not use any tools for unscrewing that could damage the body connection.

→ Unscrew actuator from the valve body.

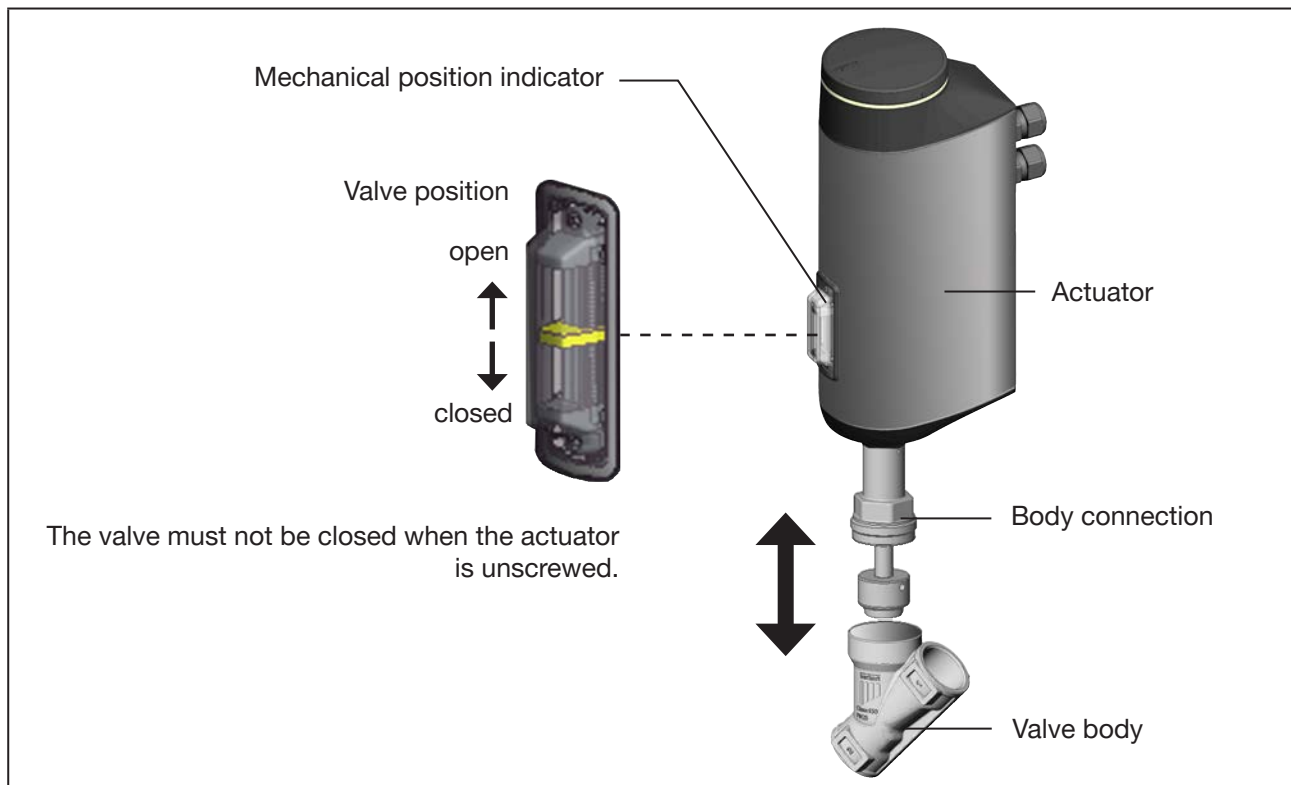

Image 11: Installation of electromotive actuator (example angle seat valve)

9.3.3 Mounting conditions

Installation position: any

Flow direction: indicated on the type label with an arrow and the digits 1 and 2. The 1 and 2 are also on the valve body for identification. The flow direction is under the seat.

Pipelines: ensure that pipelines are in alignment.

- Filter:** required for devices with approval as per EN 161. According to EN 161 “Automatic shut-off valves for gas burners and gas appliances”, a dirt trap, which prevents the penetration of a 1 mm test pin, must be installed upstream of the valve in the pipeline.
- Preparation:** Clear impurities from pipelines (seal material, metal chips, etc.).

9.3.4 Weld the valve body into the pipeline

! DANGER!

Risk of injury from high pressure.

- ▶ Before working on the system, switch off the pressure and vent or empty the lines.

NOTE!

The electronics assembly in the actuator will be damaged by the effects of heat.

- The actuator must be removed before the valve body is welded in.

→ Weld the valve body into the pipeline.

- ⚠ Ensure that there is no voltage present and minimal vibration during installation.

9.3.5 Mounting actuator on the valve body

→ ⚠ Before installing the actuator, check whether the graphite seal for the valve body is present and undamaged.

→ Replace damaged or missing graphite seal.

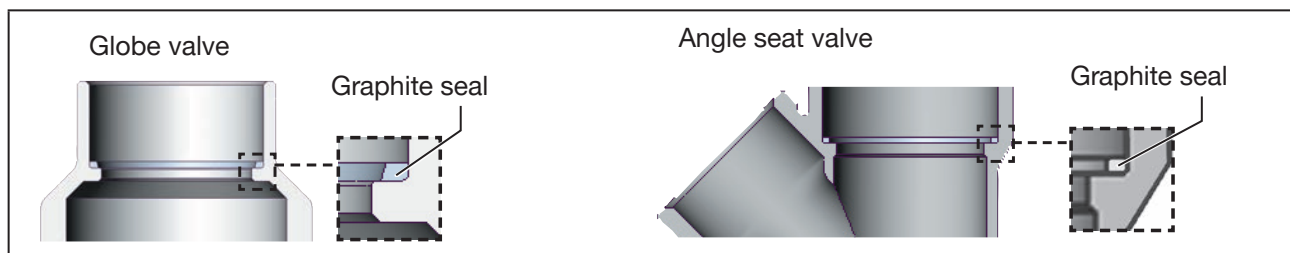

Image 12: Valve body graphite seal

! DANGER!

Danger due to incorrect lubricants.

Unsuitable lubricant may contaminate the medium. There is a risk of explosion in oxygen applications.

- ▶ For specific applications, e.g. oxygen or analysis applications, use approved lubricants only.

→ Grease the external thread of the body connection if necessary (e.g. with Klüberpaste UH1 96-402 from Klüber).

→ Position the external thread on the internal thread of the body connection. See [“Image 11: Installation of electromotive actuator \(example angle seat valve\)”](#).

→ Place on the body connection with a suitable open-end wrench.

 Do not use any tools for unscrewing that could damage the body connection (e.g. pipe wrench).



WARNING!

Risk of injury when failing to observe tightening torque value.

Failure to observe the tightening torque value is dangerous due to the risk of damage to the device.

► Observe the tightening torque value.

→ Screw actuator onto valve body.

DN connection (valve body) [DN]	Tightening torque for body connection [Nm]
10/15	45 ± 3
20	50 ± 3
25	60 ± 3
32	65 ± 3
40	
50	70 ± 3
65	100 ± 3
80	120 ± 5
100	150 ± 5

Table 11: Tightening torque for body connection



Holding device

To protect the valve actuator from damage resulting from forces and vibrations, a holding device is recommended. This is available as an accessory. See chapter [“22 Accessories, replacement parts”](#).

9.3.6 After installation

→ Electrically connect the device.

The position of the ports can be changed by turning the actuator through 360°. For a description see chapter [“9.4 Rotating the actuator”](#).



The description of the electrical connection process can be found in chapter [“10 Electrical installation”](#).

NOTE!

Damage to valve body, seat seal or diaphragm.

► To prevent damage, execute the X.TUNE function first after establishing the electrical connection. Only then should the operating state be set to AUTOMATIC.

→ Carry out X.TUNE function for end position. See chapter [“11.4 Adjustment of position controller – execute X.TUNE”](#) on page 48.

9.4 Rotating the actuator

The position of the ports can be changed by turning the actuator through 360°.

NOTE!

Damage to the seat seal and seat contour when valve closed.

If the valve is closed when the actuator is turned, the seat seal and the seat contour can be damaged.

- If the valve is closed: Before turning the actuator, open the valve with the mechanical manual override. For a description see "[15.2 Actuating the valve mechanically](#)".

→ For devices that have not been installed, clamp the valve body in a holding device.

→ Place a suitable open-end wrench (width across flats M41) on the hexagon head of the actuator.

→ Move the actuator into the required position by turning it clockwise.

If only turning counterclockwise is technically possible for installation, observe the following safety warning:



WARNING!

Risk of injury from discharge of pressure and escaping medium.

If the actuator is turned counterclockwise, the body connection can loosen.

- ▶ When turning counterclockwise, hold the hexagon of the body connection with a 2nd open-ended wrench.

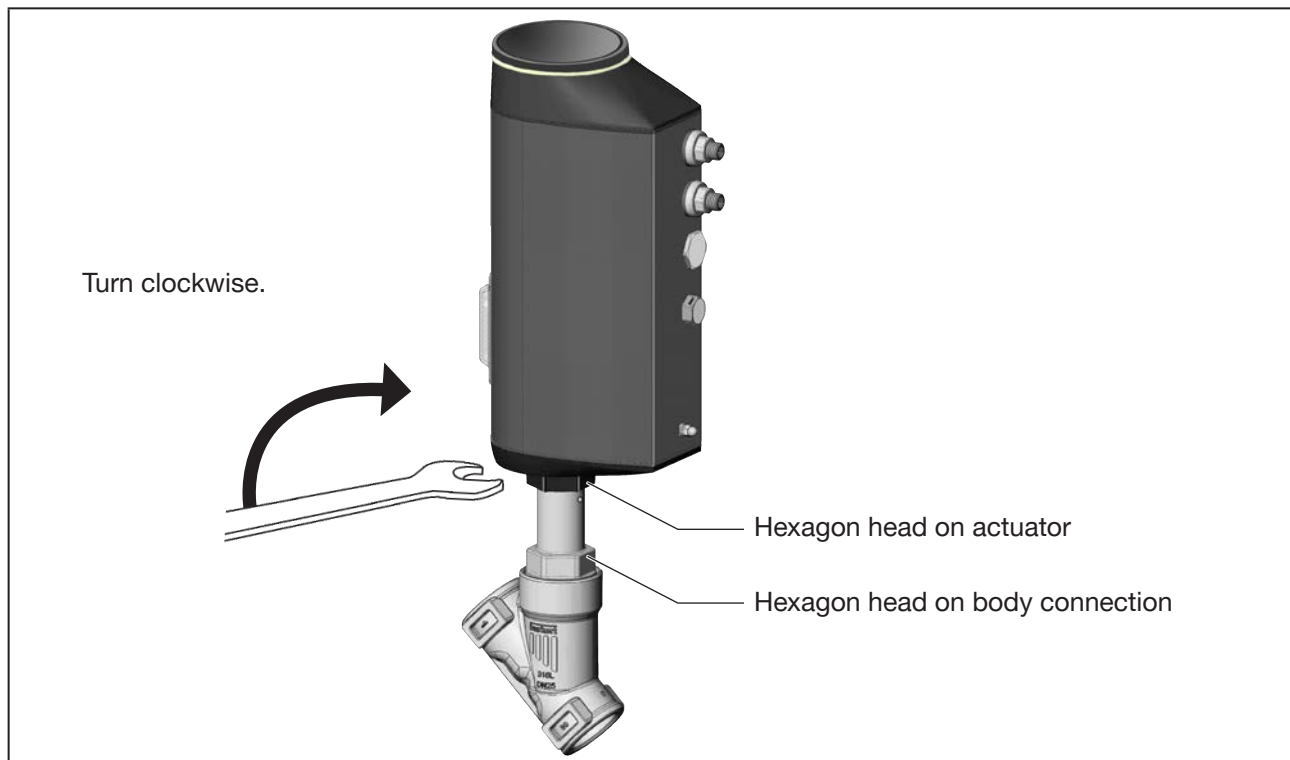

Image 13: Turning actuator

9.5 Holding device

The holding device protects the valve actuator from damage resulting from forces and vibrations. The holding device is available as an accessory in 2 sizes. See chapter “[22 Accessories, replacement parts](#)”.

9.5.1 Mounting the holding device

→ Attach the holding device to the pipe between the valve body and the actuator as shown in the picture.

In case of existing relief bore:

NOTE!

Make sure that the relief bore, which is used to detect leaks, is not covered.

→ Fix the holding device in place by suitable means.

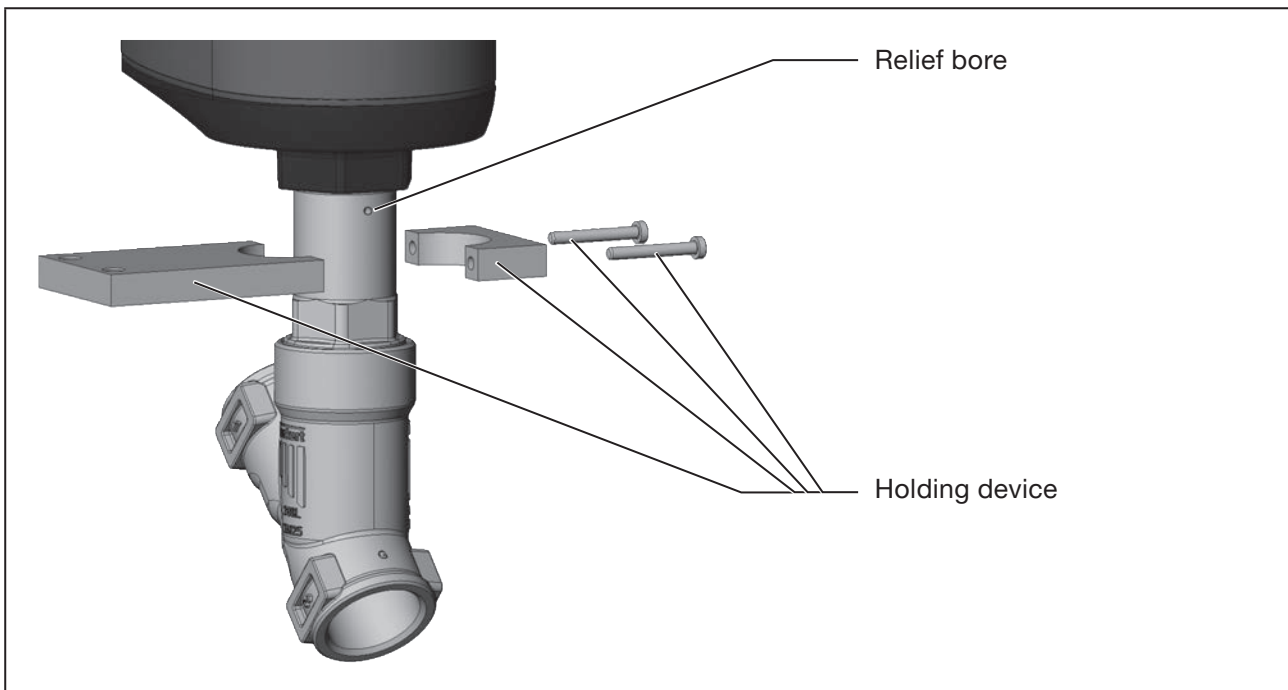

Image 14: Mounting the holding device

10 ELECTRICAL INSTALLATION

The electromotive valve is available with two connector options:

- With a circular plug-in connector (multi-pin variant)
- Cable gland with connection terminals

Signal values

Operating voltage: 24 V ---

Digital input for position signal: 0...5 V = log "0"; 10...30 V = log "1"

10.1 Electrical installation with circular plug-in connector

10.1.1 Safety instructions



WARNING!

Risk of injury due to improper installation.

- ▶ Installation may be carried out by authorised technicians only and with the appropriate tools.
- ▶ Observe general engineering standards & rules during installation.

Risk of injury due to unintentional activation of the system and uncontrolled restart.

- ▶ Secure the system to prevent unintentional activation.
- ▶ Following installation, ensure a controlled restart.

NOTE!

To ensure electromagnetic compatibility (EMC) the functional earth must be connected to earth with a short line (max. 1 m). The functional earth must have a cross-section of at least 1.5 mm².



Choice of connection line:

When choosing the length and cross-section of the individual wires, take into account the voltage drop in relation to the maximum supply current.

- Connect the device in accordance with the tables.
- Perform the necessary basic configuration and adjustments for the electromotive valve after the operating voltage has been established. For a description see chapter "[11 Start-up](#)".

10.1.2 Description of circular plug-in connectors

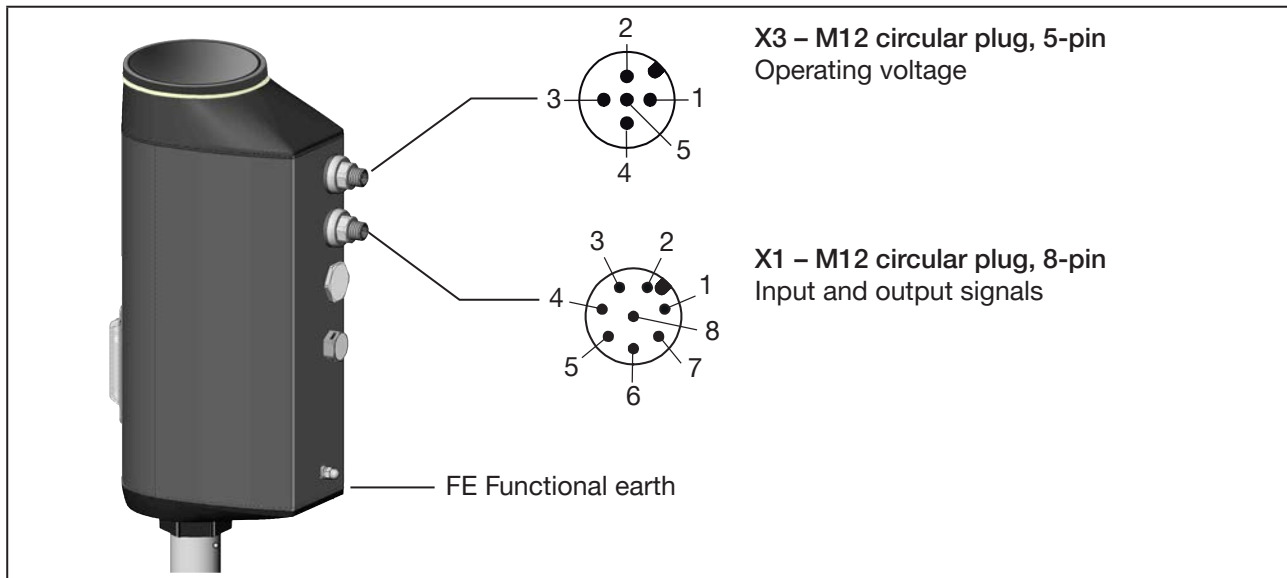

Image 15: Description of circular plug-in connectors

10.1.3 X1 – M12 circular plug, 8-pin

Pin	Wire colour*	Layout (from device perspective)
Input signals from control centre (e.g. PLC)		
1	white	Digital input + 0...5 V (log. 0) 10...30 V (log. 1)
Output signals to control centre (e.g. PLC) only required with analogue output and/or digital output option		
4	yellow	Digital output 1 24 V/0 V
3	green	Digital output 2 24 V/0 V
2	brown	Digital inputs and digital outputs GND
* The specified wire colours refer to the connection cable, which is available as an accessory with ID no. 919061.		

Table 12: X1 – M12 circular plug, 8-pin

10.1.4 X3 – M12 circular plug, 4-pin or 5-pin, operating voltage and büS/CANopen communication

Pin	Wire colour		Assignment (device side)
	without büS/CANopen network 4-pin connection*	with büS/CANopen network**	
1	- (connection not required)	CAN Shield	
2	white	red	+24 V $\pm 10\%$ max. residual ripple 10 %
3	blue	black	GND / CAN_GND
4	- (connection not required)	white	CAN_H
5	- (not available with 4-pin socket)	blue	CAN_L

* The specified wire colours relate to the 4-pin M12 connection cable, which is available as an accessory with ID no. 918038.

** The specified wire colours relate to the büS cable, which is available as an accessory
See „Cabling Guide for büS/EDIP“ at country.burkert.com

Table 13: X3 – M12 circular plug, 5-pin, operating voltage and büS/CANopen communication



Electrical installation with or without büS/CANopen network:

To use the büS/CANopen network (CAN interface), a shielded 5-wire cable with a 5-pin socket must be used.

If the büS/CANopen network is not used, only the operating voltage must be connected and a 4-wire cable with a 4-pin socket can be used



Additional information about cabling for büS networks is available at manual „Cabling Guide for büS/EDIP“ at country.burkert.com

→ Perform the necessary basic setting and adjustments for the electromotive control valve after the operating voltage has been established. For description see chapter “11.2 Base settings”.

10.2 Electrical installation with cable gland

10.2.1 Safety instructions

WARNING!

Risk of injury due to improper installation.

- ▶ Installation may be carried out by authorised technicians only and with the appropriate tools.
- ▶ Observe general engineering standards & rules during installation.

Risk of injury due to unintentional activation of the system and uncontrolled restart.

- ▶ Secure plant to prevent unintentional activation.
- ▶ Following installation, ensure a controlled restart.

NOTE!

To ensure electromagnetic compatibility (EMC) the functional earth must be connected to earth with a short line (max. 1 m). The functional earth must have a cross-section of at least 1.5 mm².

10.2.2 Access to connection terminals

To access the terminals, open the device as described below.



Devices with ATEX approval or IECEx approval are secured with a magnetic lock.

The removal of the cover is described in the supplementary instructions for the electromotive control valves with ATEX approval and IECEx approval.

1. Remove blind cover:

→ To unlock the blind cover, turn it counterclockwise and remove.

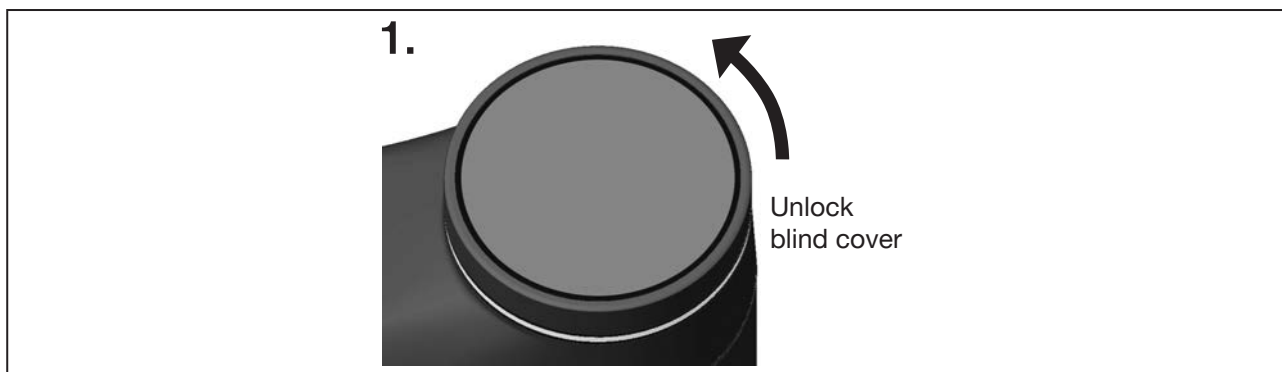

Image 16: Remove blind cover

2. Remove the LED and storage module:

→ Remove the 2 fastening screws (Allen key, width across flats 3 mm).

→ Grab the LED and storage module by both sides of the metal housing and lift it out.

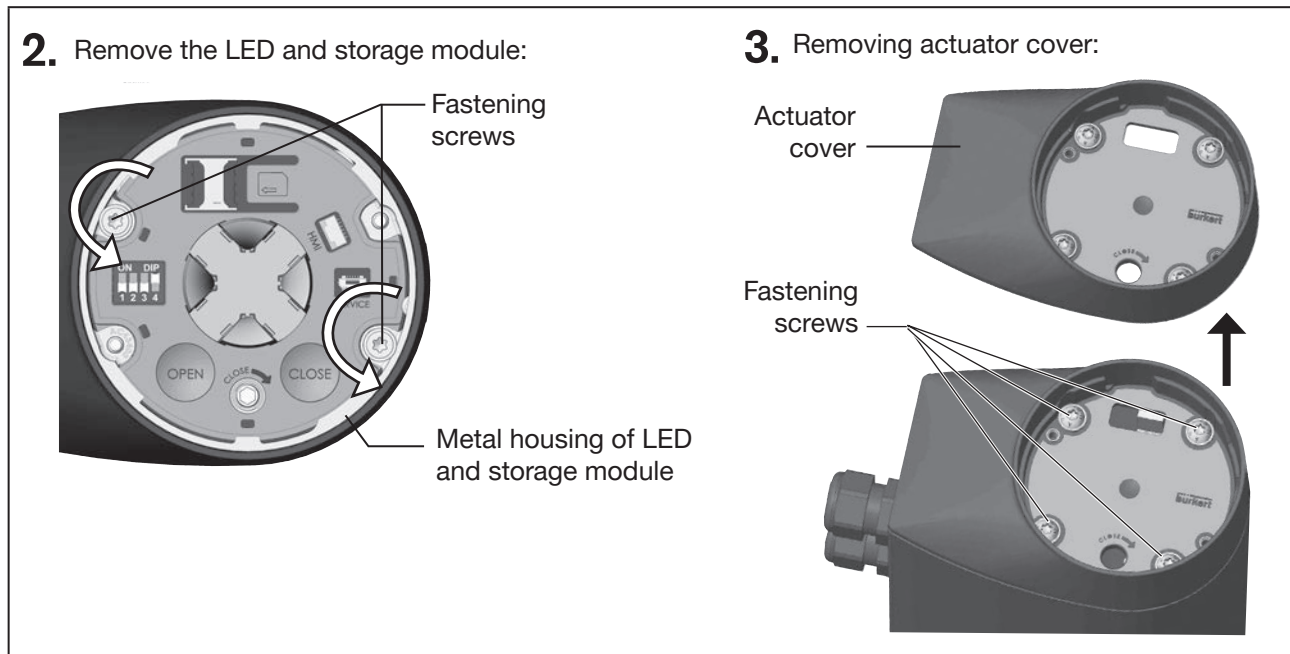

Image 17: Remove the LED and storage module and remove the actuator cover

3. Removing actuator cover:

→ Loosen the 4 fastening screws (hexalobular-internal screws T25).
The screws are integrated securely in the actuator cover.

→ Remove the actuator cover.

The connection terminals are now accessible.

10.2.3 Connecting the cable

→ Push the cable through the cable gland.

NOTE!

Take note for connection to spring-loaded terminals.

- ▶ Minimum length of wire ferrules: 8 mm
- ▶ Maximum cross-section of wire ferrules: 1.5 mm² (uncollared), 0.75 mm² (collared).

→ Strip at least 8 mm of insulation from the wires and crimp ferrules on.

→ Attach the wires to the terminals. The terminal layout is provided in the tables below from [Page 44](#).

→ Tighten union nut of cable gland (tightening torque approx. 1.5 Nm).

NOTE!

The ingress of dirt or moisture may cause damage or malfunction.

To preserve IP65 protection, ensure the following:

- ▶ Unused cable glands must be sealed using dummy plugs.
- ▶ The union nuts of cable glands must be tightened. Tightening torque, dependent on the cable size or dummy plugs, approx. 1.5 Nm.

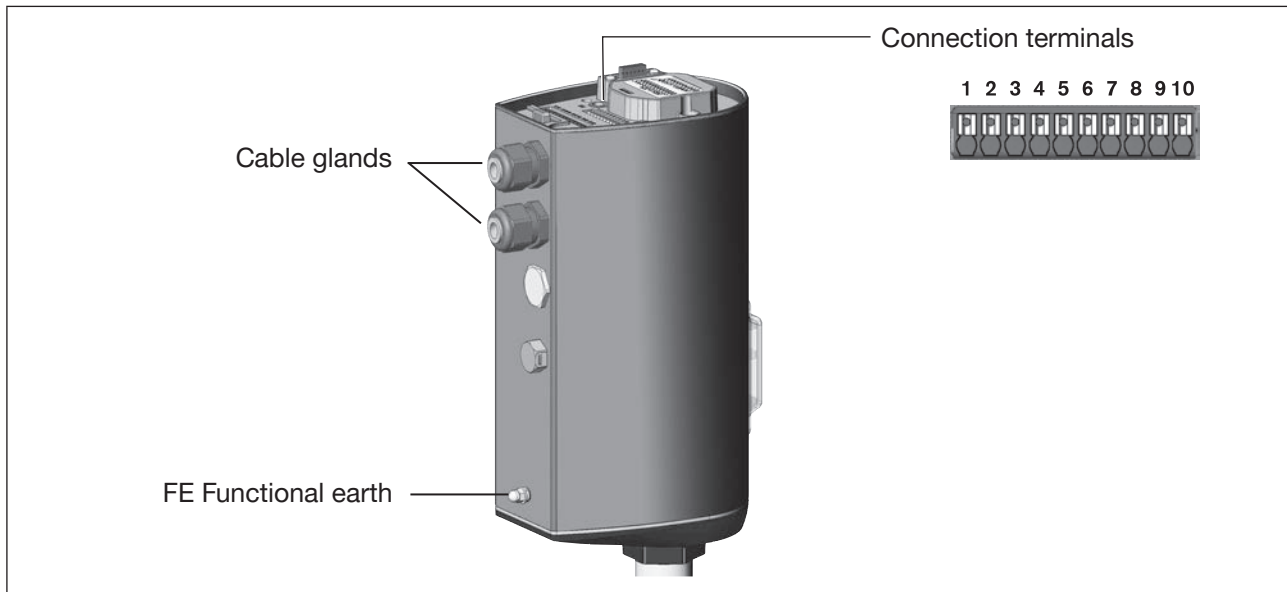

Image 18: Connecting the cable

→ Connect the device in accordance with the tables.

10.2.4 Terminal layout – input signal from control centre (e.g. PLC)

Clip	Layout (from device perspective)	
5	Digital input +	+  0...5 V (log. 0) 10...30 V (log. 1)
4	Digital input, GND	relates to GND operating voltage (GND Clip)
8	Digital output 1	24 V/0 V
6	Digital output 2	24 V/0 V
7	Digital output GND	

Table 14: Terminal layout – input signal from control centre (e.g. PLC)

10.2.5 Terminal layout – operating voltage and bÜS network



Clip	Layout (from device perspective)	
	CAN shield	
10	24 V  ± 10% max. residual ripple 10%	
9	GND	
1*	CAN_GND  Only connect when a separate line is used for CAN.	
2*	CAN_H	
3*	CAN_L	

Table 15: Terminal layout – operating voltage and bÜS network



***Electrical installation of bÜS network:**

Terminals 1, 2 and 3 (CAN interface) are for the bÜS network connection.
Terminal 1 is bridged internally with terminal 9, however it is not designed for the operating voltage.

10.2.6 Close device

NOTE!

The ingress of dirt or moisture may cause damage or malfunction.

To preserve IP65 protection, ensure the following before closing the device:

- ▶ The seal in the actuator housing/actuator cover must be inserted and undamaged.
- ▶ The seal surfaces must be clean and dry.

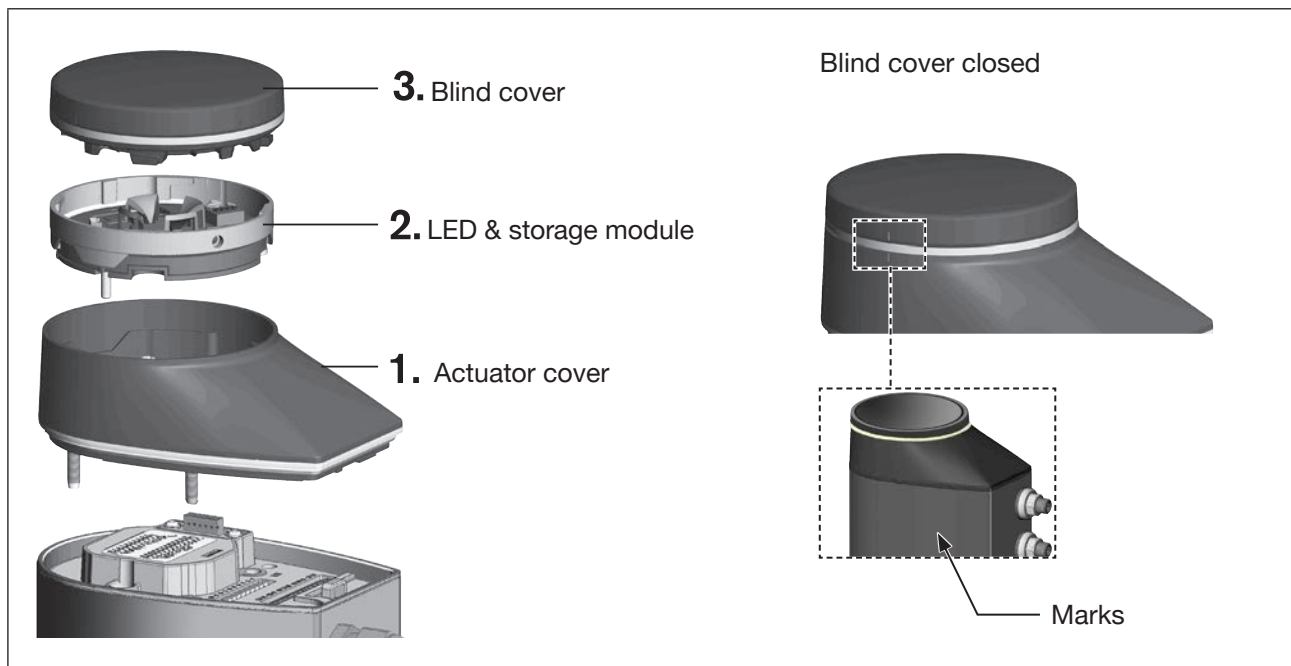

Image 19: Close device

1. Mounting actuator cover

→ Place actuator cover on the actuator housing.

→ First screw in the four fastening screws (hexalobular-internal screws T25) by hand lightly, then tighten them (tightening torque: 5.0 Nm).

2. Mount LED and storage module:

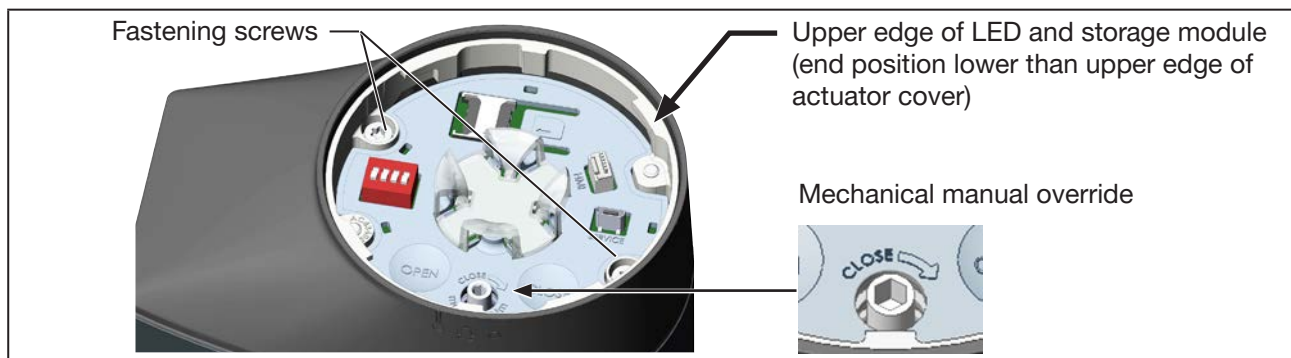

Image 20: Mount LED and storage module:

- Place the LED and storage module onto the actuator cover.
Align the recess for the manual override in the centre, paying attention to the correct alignment of the electrical plug connection.
- Carefully press down the LED and storage module by hand.
The end position is reached if the upper edge of the module is fully and evenly recessed in the actuator cover.

NOTE!

The plug connection will be damaged if the LED and storage module is not correctly inserted.

- ▶ Before the fastening screws are tightened, the LED and storage module must be fully recessed in the actuator cover.

- Tighten 2 fastening screws (hexalobular-internal screws T20).
Observe the tightening torque of 1.1 Nm!

3. Close device with blind cover or display module

For devices with display module:

- Connect the connection cable to the HMI interface.
- Fit the display module and turn clockwise until the marking at the edge is directly over the marking for the actuator cover.

For devices with blind covers:

- Fit the blind cover and turn clockwise until the marking at the edge is directly over the marking for the actuator cover.

Perform the necessary basic configuration and adjustments for the electromotive valve after the operating voltage has been established. For a description see chapter [“11 Start-up”](#).

11 START-UP

11.1 Safety instructions



WARNING!

Risk of injury due to improper operation.

Improper operation may result in injuries as well as damage to the device and the surrounding area.

- ▶ The operating personnel must know and understand the contents of the operating instructions.
- ▶ The safety instructions must be followed and the device used only as intended.
- ▶ Only authorised technicians may start up the device or system.

11.2 Base settings

Type of base setting (observe sequence)		Factory default setting
1.	Set effective direction	Close/open (dependent on device variant)
	Enable/disable safety position	enabled
2.	Adjustment of position control (X.TUNE function)	performed
3.	Set AUTOMATIC operating state	MANUAL

Table 16: Overview: Base setting for the electromotive 2/2-way valve

NOTE!

Consider for devices requiring disassembly for installation.

If the actuator is disassembled, X.TUNE function must be carried out again before start-up. See chapter [“11.4 Adjustment of position controller – execute X.TUNE”](#)

- ▶ The device must be in MANUAL operating state.

11.3 Set safety position and effective direction

The effective direction and safety position are set using DIP switches 1 and 2.

Effective direction	DIP switch 2		DIP switch 1		
	Switch position	Set-point value		Switch position (safety position enabled/disabled)	Safety position
		(0...5 V) Log 0	(10...30 V) Log 1		
NC	OFF	Valve closed	Valve open	ON	Valve closed
				OFF	none (actuator stops)
NO	ON	Valve open	Valve closed	ON	Valve open
				OFF	none (actuator stops)

Table 17: Set safety position and effective direction

11.4 Adjustment of position controller – execute X.TUNE

When executing the X.TUNE function the position control is adjusted at the physical stroke of the electromotive actuator in use.

Devices come with the X.TUNE function performed by the manufacturer.

NOTE!

Only perform X.TUNE if absolutely necessary.

The X.TUNE function only has to be executed again if the actuator has been dismantled or the valve body has been replaced.



WARNING!

Danger due to uncontrolled process after executing the X.TUNE function.

Executing X.TUNE under operating pressure will cause an actuator error. The result is an uncontrolled process.

- ▶ Never perform X.TUNE under operating pressure.
- ▶ Secure the system to prevent unintentional activation.

11.4.1 Adjustment of position controller with buttons in device

The two buttons for triggering X.TUNE are located beneath the blind cover.

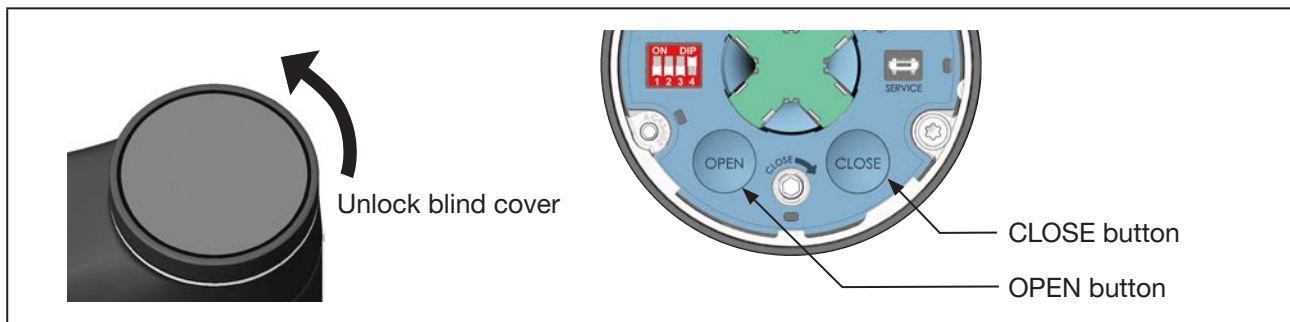

Image 21: Adjustment of position controller with buttons in device



Devices with ATEX approval or IECEx approval are secured with a magnetic lock.

The removal of the cover is described in the supplementary instructions for the electromotive control valves with ATEX approval and IECEx approval.

→ To unlock the blind cover, turn it counterclockwise and remove.

How to trigger the X.TUNE function:

⚠ Make sure that there is no operating pressure.
Only perform X.TUNE when necessary.

→ Hold down the OPEN and CLOSE buttons together at the same time for 5 seconds.

The LED illuminated ring will light up orange while the X.TUNE is executed.

When X.TUNE is finished, the LED illuminated ring returns to its previous status.

11.4.2 Adjustment of position control on PC



Settings are created on the PC using the bÜS service interface and the Bürkert Communicator PC software. It requires the USB bÜS interface set available as an accessory.

To trigger the X.TUNE function, you must switch to the “Maintenance” detailed view for position controllers.

How to switch to detailed view:

→ Select **Positioner**.

→ Switch to **MAINTENANCE**.

✔ You are now in the “Maintenance” detailed view.

How to trigger the X.TUNE function:

⚠ Make sure that there is no operating pressure.

→ Select **CALIBRATION**.

→ Select **X.TUNE**.

The following text appears: “Select seal material (see type label)!”

→ Select seal material.

The following question appears: “Do you really want to start X.TUNE?”

⚠ Only confirm if the usage of X.TUNE is really necessary.

→ Start X.TUNE.

✔ This will execute the X.TUNE function.



If X.TUNE is aborted due to an error, a message will appear (see subsequent table).

Possible messages when X.TUNE is aborted	Description
Device error present.	There is an error present that makes it impossible to execute X.TUNE.
Timeout.	X.TUNE could not be executed within the time limit due to an error.
The motor current is too great.	The motor current is too great for the X.TUNE function.
The lower end position of the valve is not recognised.	The lower end position of the valve cannot be recognised by the position sensor.

Table 18: Possible error messages after abort of the X.TUNE function

11.5 Set AUTOMATIC operating state

Set AUTOMATIC operating state:

→ Set DIP switch 4 to AUTOMATIC.

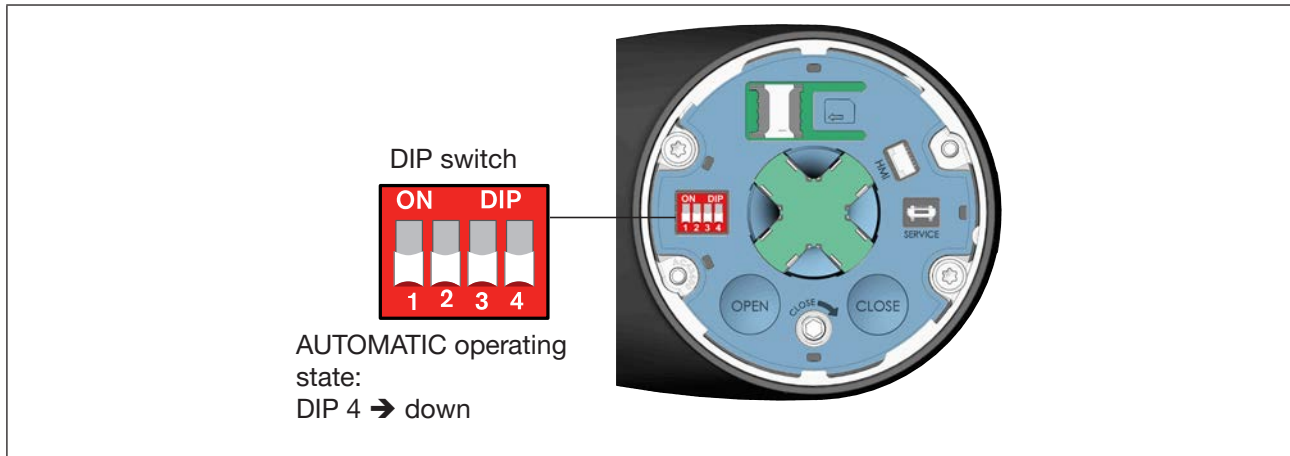

Image 22: Set AUTOMATIC operating state

12 OPERATION



WARNING!

Risk of injury from improper operation.

Improper operation may result in injuries as well as damage to the device and its surroundings.

- ▶ The operating personnel must know and understand the contents of the operating instructions.
- ▶ The safety instructions must be followed and the device used only as intended.
- ▶ Only authorised technicians may start up the device or system.

Different operating elements are available for operating the device.

- **Standard devices**

Operation is via 2 capacitive buttons and 4 DIP switches.

- **Additional operating options**

Expanded functions can be set using a PC or tablet. Settings are created using the büS service interface and the “Bürkert Communicator” PC software.

It requires the USB büS interface set available as an accessory.

12.1 Overview: Availability of the operating elements

Operating element	Function
4 DIP switches	Enable safety position
	Select safety position
	Not used
	Switch to AUTOMATIC, MANUAL operating state
OPEN button	Opening the valve
CLOSE button	Closing the valve:
Mechanical manual override	Mechanically opening or closing the valve
SIM card holder	Holder for using the SIM card available as an accessory
büS service interface	For connecting a CAN adapter or the USB büS interface set available as an accessory
Bürkert Communicator PC software	Software for configuration and setting the device on a PC or tablet

Table 19: Operating possibilities

12.2 Display elements

Description of the display elements:

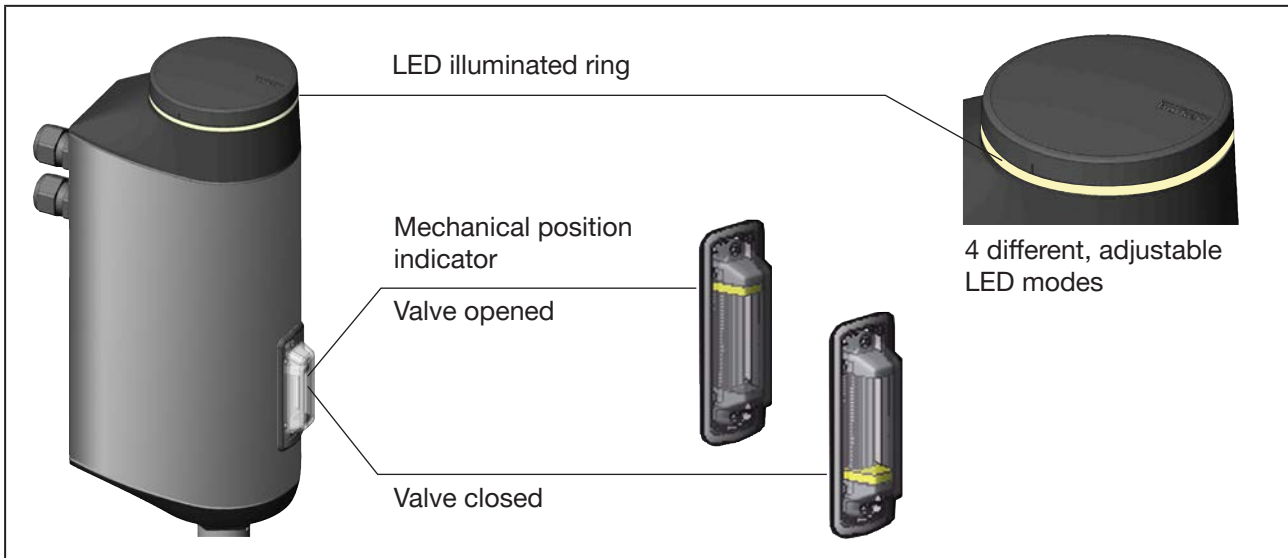

Image 23: Display elements

12.2.1 LED illuminated ring

The transparent LED illuminated ring that transmits the light of the LEDs to the outside is fitted to the blind cover. The LED illuminated ring lights up or flashes slowly or quickly in one or several alternating colours to indicate the device's state.

4 different LED modes can be set for the LED light ring:

- NAMUR operation mode*
- Valve mode*
- Valve mode + warnings* – factory pre-set operation mode
- LED off

The LED modes are set using the Bürkert Communicator PC software . For a description see chapter [“14.3 Set LED operation mode”](#).



* The complete description of the device states, errors and warnings that are displayed in LED mode can be found in chapter [“6.4 Display of the device status”](#).

12.2.2 Mechanical position indicator

The valve position is read from the mechanical position indicator even if the supply voltage fails (see [“Image 23: Display elements”](#)).

12.3 Operating elements

Presentation of the operating elements:

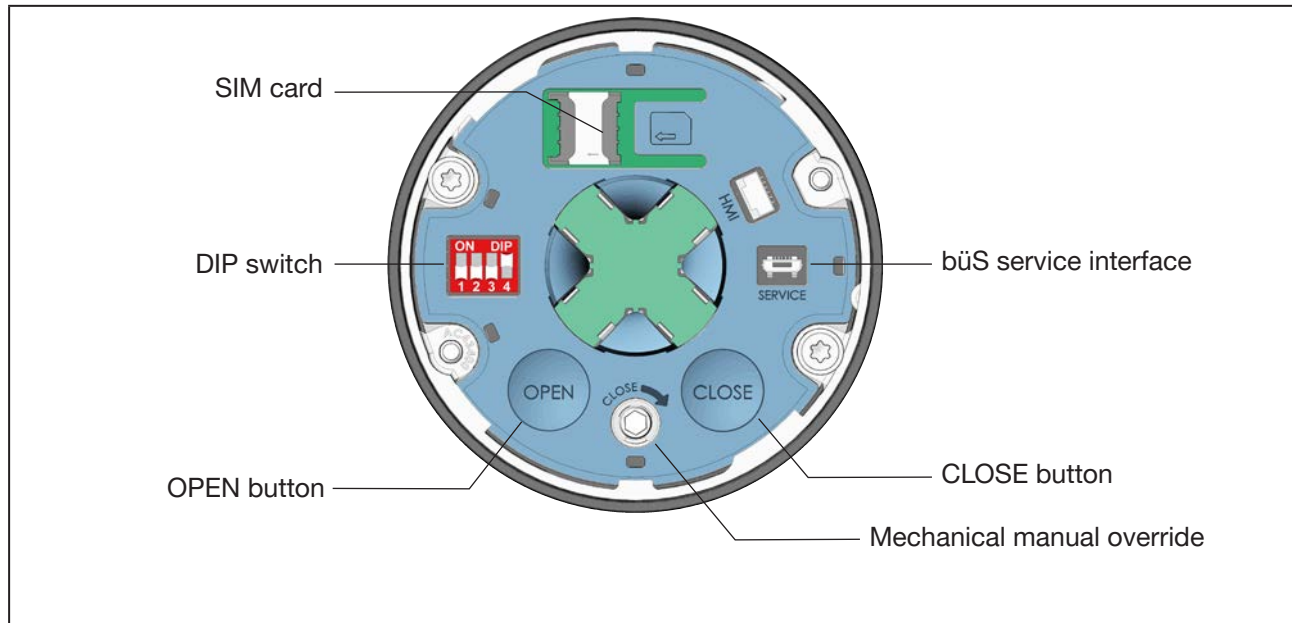

Image 24: Operating elements

12.3.1 DIP switch

Settings

- Switch 1: Enable or disable safety position (see chapter [“13.2” on page 59](#)).
- Switch 2: Select safety position between NO and NC (see chapter [“13.2” on page 59](#)).
- Switch 3: Not used.
- Switch 4: Switch between AUTOMATIC and MANUAL operating state. See chapter [“13.1” on page 58](#).

12.3.2 OPEN button and CLOSE button

- Electrical manual override: Opening valve: Press OPEN button
 Closing valve: Press CLOSE button
- Trigger X.TUNE (Autotune): For a description see chapter [“11.4 Adjustment of position controller – execute X.TUNE”](#)

12.3.3 Mechanical manual override

If there is no supply voltage, e.g. during installation or in the event of a power failure, the valve can be opened or closed using the mechanical manual override.

For a description see chapter [“15.2 Actuating the valve mechanically”](#).

12.4 büS service interface

The büS service interface can be used for quick service.

- Configuration of the device, e.g. the base setting for start-up with the PC software Bürkert Communicator. It requires the USB büS interface set available as an accessory.
- Configuration of the büS network.
The büS service interface has a direct internal connection to the büS network.
- Parameterising of operation parameters
- Error diagnostics
- Software update

Only connect the matching CAN adapter to the büS service interface. This CAN adapter is part of USB büS interface set available as an accessory.

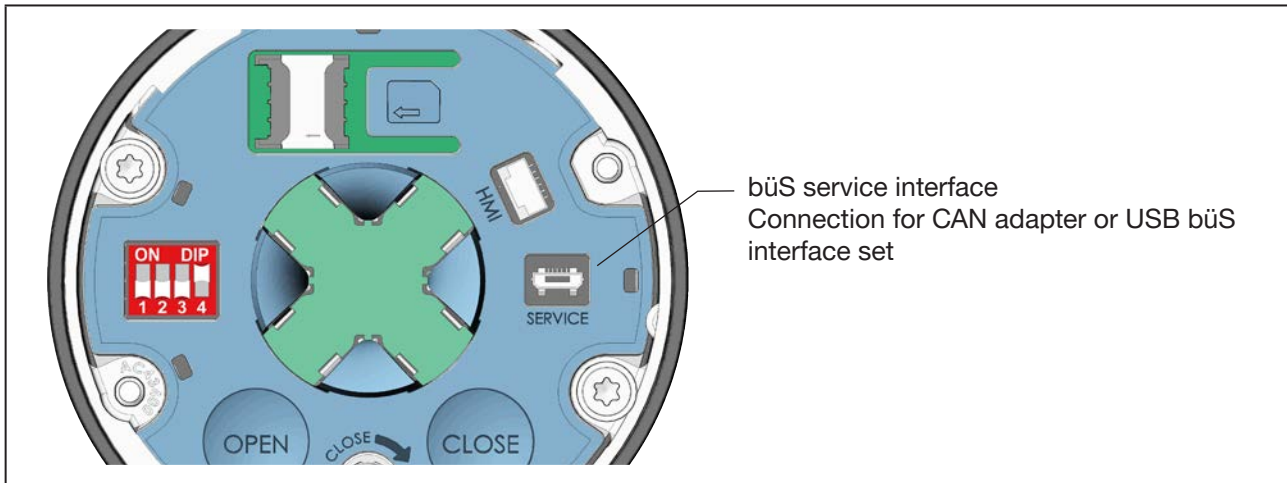

Image 25: büS service interface



For devices with EtherNet/IP, the büS service interface is inside the fieldbus gateway (see chapter “12.4 büS service interface” on page 54)

12.5 SIM card – acquire and save data (option)

The optional SIM card can be used to store device-specific values and user settings and transfer them to another device.

The SIM card is detected when the device starts and is checked for available data. This data will be transferred or overwritten accordingly:

- The SIM card does not contain any data.
The existing device-specific values and user settings are saved to the SIM card.
- The SIM card contains data compatible with the device.
The data on the SIM card are transferred by the device. The existing device-specific values and user settings are overwritten.
- The SIM card contains data that are not compatible with the device.
The device overwrites the data on the SIM card with its own device-specific values and user settings.

NOTE!

Do not use a standard SIM card for the device.

The SIM card used is a special industrial version that offers additional durability and temperature-resistance.

Only purchase the SIM card for the electromotive valves from your Bürkert sales department. See chapter “22 Accessories, replacement parts”.

Do not remove the SIM card during operation.

During operation, parameter changes are immediately saved to the SIM card.

If the SIM card is removed during operation, data may be lost and the SIM card damaged.



The SIM card can be inserted during operation.

A restart is required to ensure that the device detects the SIM card.

Inserting the SIM card:

- Place the SIM card on the surface with the SIM card symbol. The position must correspond to that shown on the symbol.
- Gently push the SIM card to the left into the holder until it stops.
- Restart the device.
The new data are transmitted.

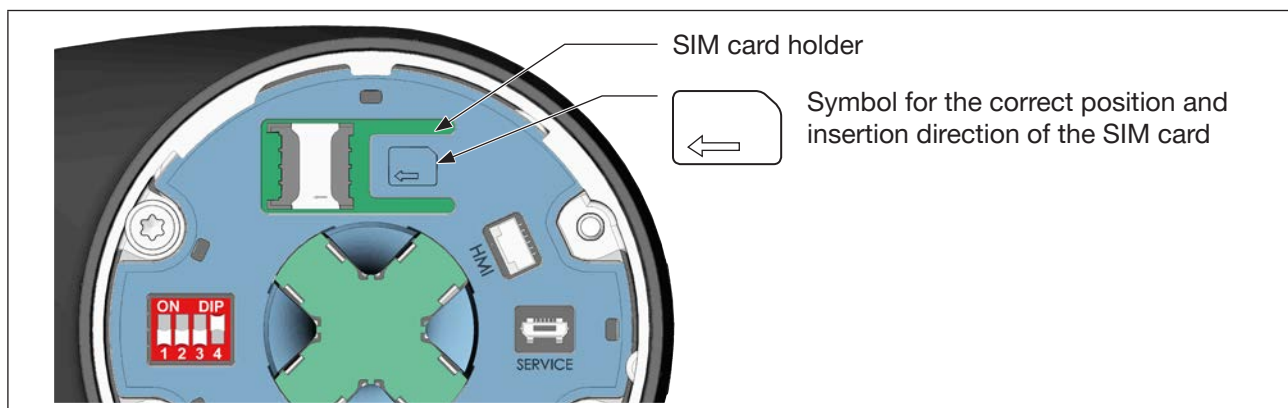

Image 26: Using the SIM card

12.6 User interface of the Bürkert Communicator PC software

Configuration area view:

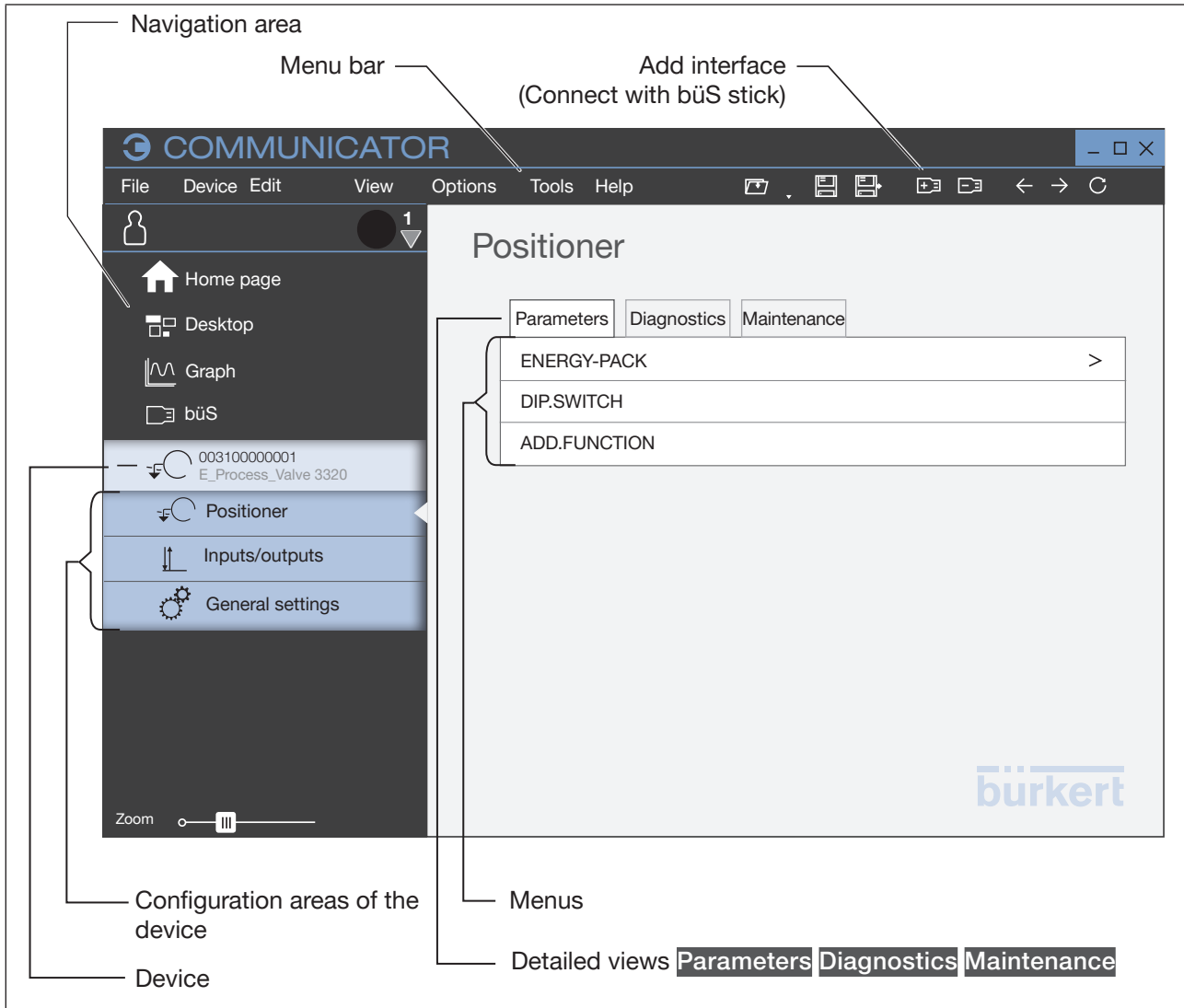

Image 27: Bürkert Communicator, configuration area view

View of the application area:

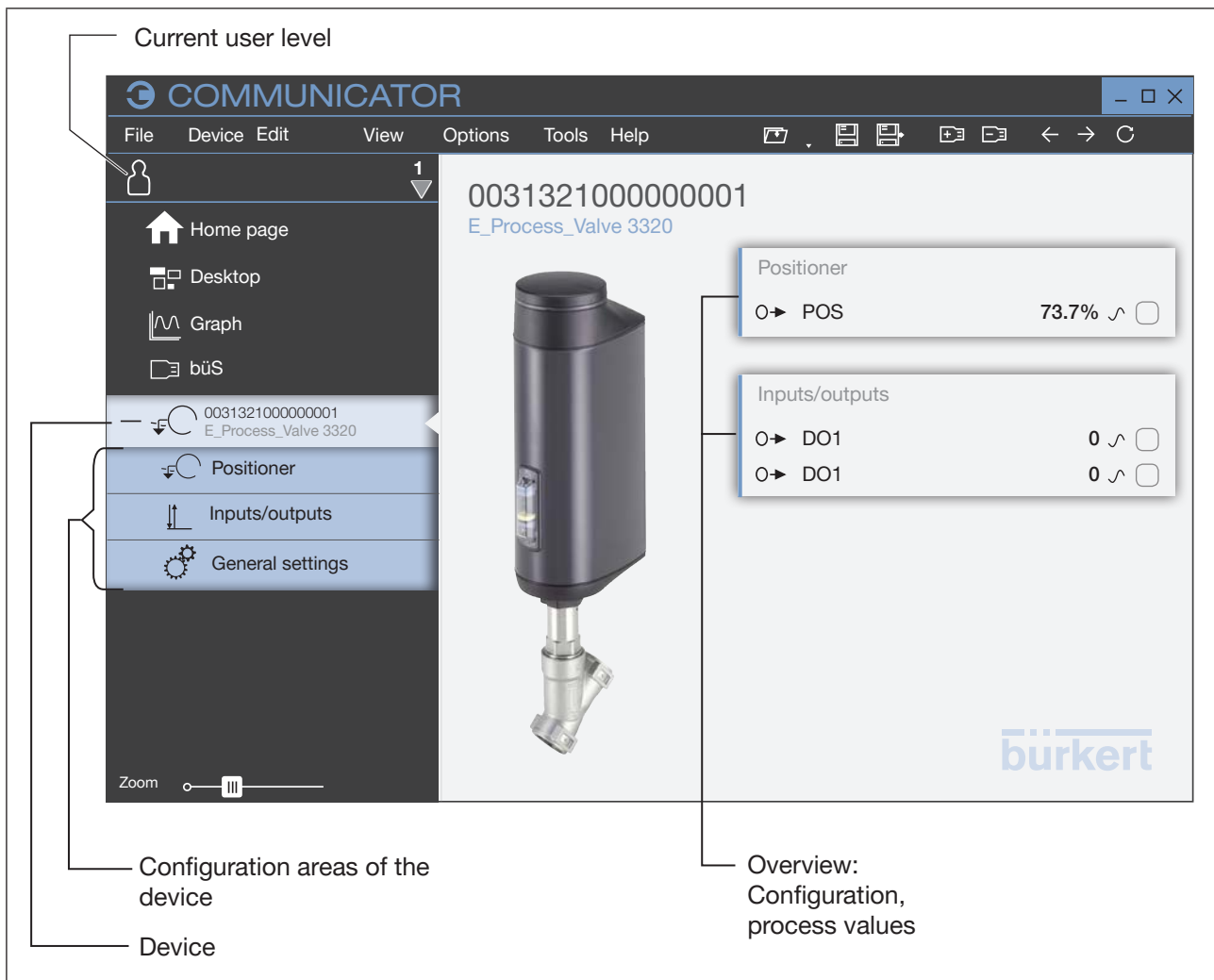



Image 28: Bürkert Communicator, "Application area" view

12.7 Establish the connection between device and Bürkert Communicator

- Install the Bürkert Communicator software on the PC.
- Use the büS stick to establish the connection between device and PC.
- Open Bürkert Communicator.
- In the menu bar, click the icon  for **Add interface**.
- Select **büS stick** or **büS via the network**.
- ✔ You have established the connection between the device or network and Bürkert Communicator. The device or devices in the network are displayed in the navigation area.

13 BASIC FUNCTIONS

The basic functions are set using the DIP switch position.

DIP switch	Basic function
1	Enable or disable safety position
2	Set safety position and effective direction (NC and NO)
3	Not used
4	Switch between AUTOMATIC and MANUAL operating state.

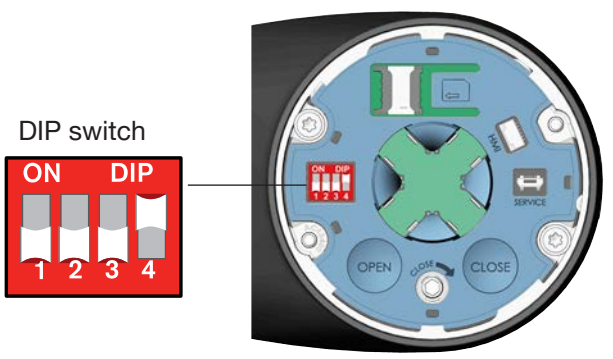

Table 20: Overview of basic functions

13.1 Changing the operating state, AUTOMATIC, MANUAL

Factory setting: Devices in their factory default state have their operating state preset to MANUAL.

DIP switch 4, which is located under the blind cover, is used to change operating state.

→ To unlock the blind cover, turn it counterclockwise and remove.



Devices with ATEX approval or IECEx approval are secured with a magnetic lock.

The removal of the cover is described in the supplementary instructions for the electromotive control valves with ATEX approval and IECEx approval.

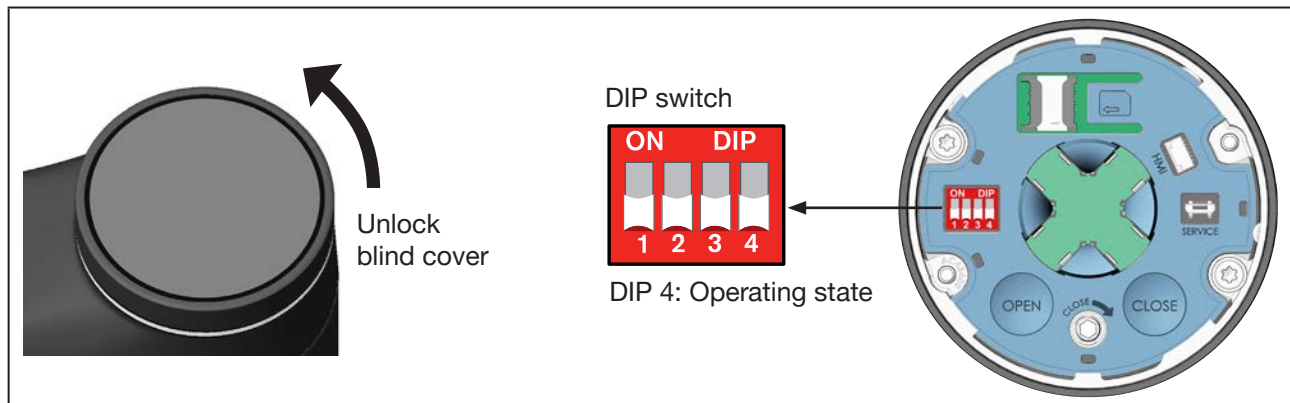
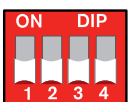

Image 29: Setting the operating state

→ Set the operating state with DIP switch 4.

	Operating state	
	AUTOMATIC: DIP 4 → down	MANUAL: DIP 4 → up (ON)

→ Close the blind cover.

13.2 Set safety position and effective direction

The effective direction and safety position are set using DIP switches 1 and 2.

Effective direction	DIP switch 2		DIP switch 1		
	Switch position	Set-point value		Switch position (safety position enabled/disabled)	Safety position
		(0...5 V) Log 0	(10...30 V) Log 1		
NC	OFF	Valve closed	Valve open	ON	Valve closed
				OFF	none (actuator stops)
NO	ON	Valve open	Valve closed	ON	Valve open
				OFF	none (actuator stops)

Table 21: Set safety position and effective direction

14 ADVANCED FUNCTIONS

14.1 X.TIME – limitation of control speed

This auxiliary function can be used to set the opening and closing times for the entire stroke, and thus limit the control speeds.



When performing the *X.TUNE* function, the minimum opening and closing time are entered for the entire stroke for *Open* and *Close*. This facilitates movement at maximum speed.

Factory setting: factory-set values through the *X.TUNE* function

If the control speed is to be reduced, values can be entered for *Open* and *Close* which lie between the minimal values to be determined by *X.TUNE* and 60 s.

Effect of a limitation of the opening speed in the event of a spike in set-point value

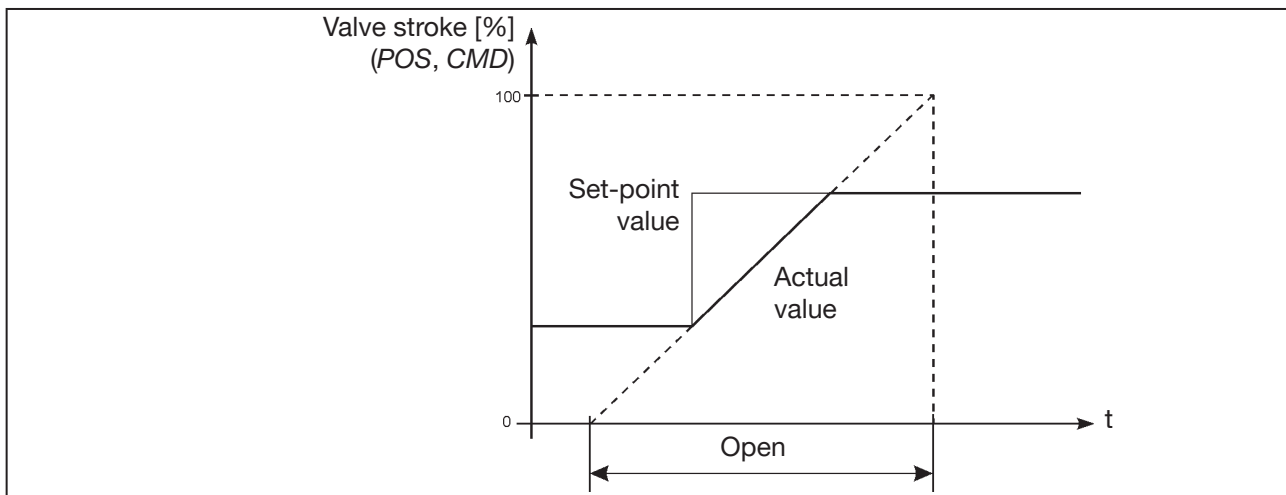

Image 30: Diagram X.TIME

Configuration using the Bürkert Communicator software on PC:



The Bürkert Communicator PC software can be downloaded free of charge from the Bürkert website.
It requires the USB bÜS interface set available as an accessory.
Communication is performed via the device's bÜS service interface.

The setting is made in the detailed view "Parameter for positioner".

How to enable the control time limit:

→ Select **Positioner**.

→ Select **ADD.FUNCTION**.

→ Select **X.TIME**.

✓ The control time limit is enabled and the menu **X.TIME** for configuration is now available.

How to configure the control time limit:

→ Select **X.TIME** in the "Parameter" detailed view.

→ Select **Opening time**.

→ Enter and confirm the lower limit value.

→ Select **Closing time**.

→ Enter and confirm the upper limit value.

✓ You have enabled and configured the control time limit.

14.2 X.LIMIT – mechanical stroke range limit

This auxiliary function limits the (physical) stroke to defined per cent values (minimum and maximum). The stroke range of the limited stroke is thereby set to 100%.

If the limited stroke range is left during operation, negative POS values or POS values greater than 100% are displayed.

Factory setting: *Min = 0%*, *Max = 100%*

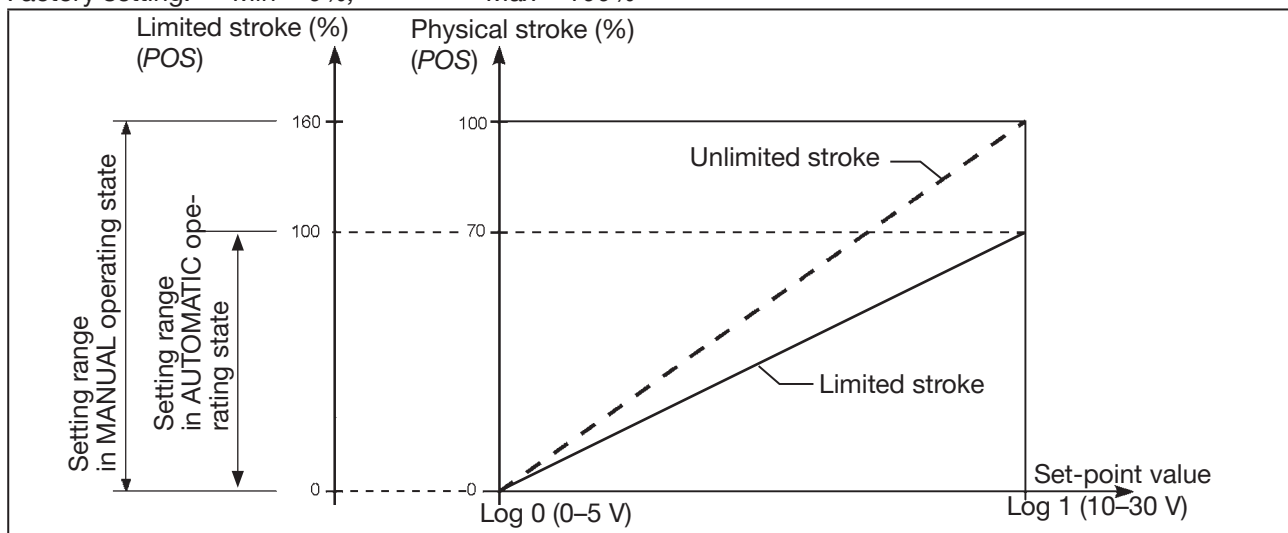

Image 31: Diagram X.LIMIT

NOTE!

The safety position (closed or open) is located at the end positions of the physical stroke.

Configuration using the Bürkert Communicator software on PC:



The Bürkert Communicator PC software can be downloaded free of charge from the Bürkert website. It requires the USB büS interface set available as an accessory. Communication is performed via the device's büS service interface.

The setting is made in the detailed view "Parameter for positioner".

How to switch to detailed view:

→ Select **Positioner**.

✓ You are now in the "Parameter" detailed view.

How to enable the mechanical stroke limit:

→ Select **ADD.FUNCTION**.

→ Select **X.LIMIT**.

✔ The mechanical stroke limit is enabled and the menu **X.LIMIT** for configuration is now available.

How to configure the mechanical stroke limit:

→ Select **X.LIMIT** in the detailed view “Parameter”.

→ Select **Maximum**.

→ Enter and confirm the upper limit value.

✔ You have enabled and configured the mechanical stroke limit.

14.3 Set LED operation mode

Configuration using the Bürkert Communicator software on PC:



The Bürkert Communicator PC software can be downloaded free of charge from the Bürkert website.

It requires the USB bÜS interface set available as an accessory.

Communication is performed via the device’s bÜS service interface.

The setting is made in the detailed view “Parameter for general settings”.

How to switch to detailed view:

→ Select **General settings**.

✔ You are now in the “Parameter” detailed view.

How to set LED operation mode:

→ Select **Status LED**.

→ Select **Operation mode**.

The following LED operation modes are available:

NAMUR operation mode

Valve mode

Valve mode + warnings

LED off

✔ You have set the LED operation mode.

14.4 Setting the colours for indicating valve position

The colours on the LED light ring that indicate the valve positions can be set individually.

Configuration using the Bürkert Communicator software on PC:



The Bürkert Communicator PC software can be downloaded free of charge from the Bürkert website.

It requires the USB bÜS interface set available as an accessory.

Communication is performed via the device's bÜS service interface.

The setting is made in the detailed view "Parameter for general settings".

How to switch to detailed view:

→ **Select General settings.**

✔ You are now in the "Parameter" detailed view.

How to set the colour for the valve position.

→ **Select Status LED.**

→ Select **Valve mode** or **Valve mode + warnings**.

→ In the submenus **"Valve opened"** and **"Valve closed"**, select the colour for the respective valve position.

✔ You have set the colours that are used to indicate the valve positions on the LED light ring.

15 MANUAL OVERRIDE OF VALVE

The actuation of the valve can be manually overridden by electrical or mechanical means. Electrical manual override is usually used to manually open and close the valve.

The valve must be opened and closed via mechanical manual override if there is a power failure. The valve must only be manually overridden while in a de-energised state.

15.1 Enable valve electrically

The valve can be manually enabled electrically or using two buttons located on the LED & storage module under the blind cover.

To actuate the valve, the device must be in MANUAL operating state.

The 2 buttons for opening and closing the valve are under the blind cover.

! Devices with ATEX approval or IECEx approval are secured with a magnetic lock.
The removal of the cover is described in the supplementary instructions for the electromotive control valves with ATEX approval and IECEx approval.

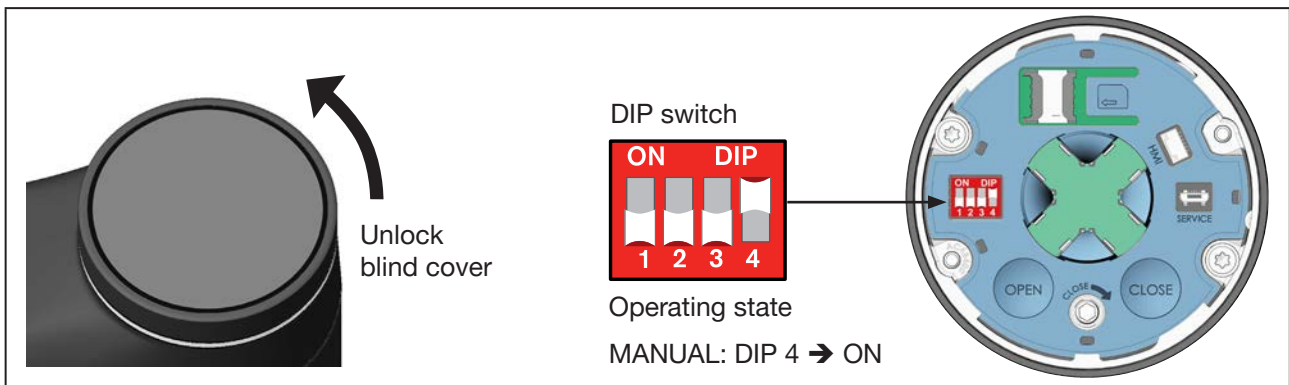

Image 32: Setting MANUAL operating state

→ To unlock the blind cover, turn it counterclockwise and remove.

→ Set DIP switch 4 to ON. The device is in MANUAL operating state (see “Image 32”).

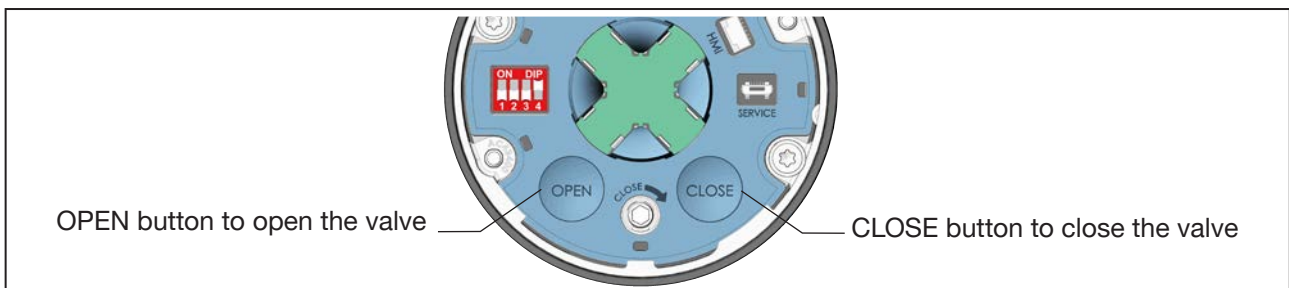

Image 33: Electrical manual override for devices

→ Open and close the valve using the OPEN and CLOSE button (see “Image 33”).

→ Push DIP switch 4 back. The device is back in AUTOMATIC operating state.

→ Close the blind cover.

15.2 Actuating the valve mechanically

If there is no supply voltage, e.g. during installation or in the event of a power failure, the valve can be opened or closed using the mechanical manual override.

NOTE!

The mechanical manual override may be used only when it is de-energised, otherwise the device may be damaged.



Devices with ATEX approval or IECEx approval are secured with a magnetic lock.

The removal of the cover is described in the supplementary instructions for the electromotive control valves with ATEX approval and IECEx approval.

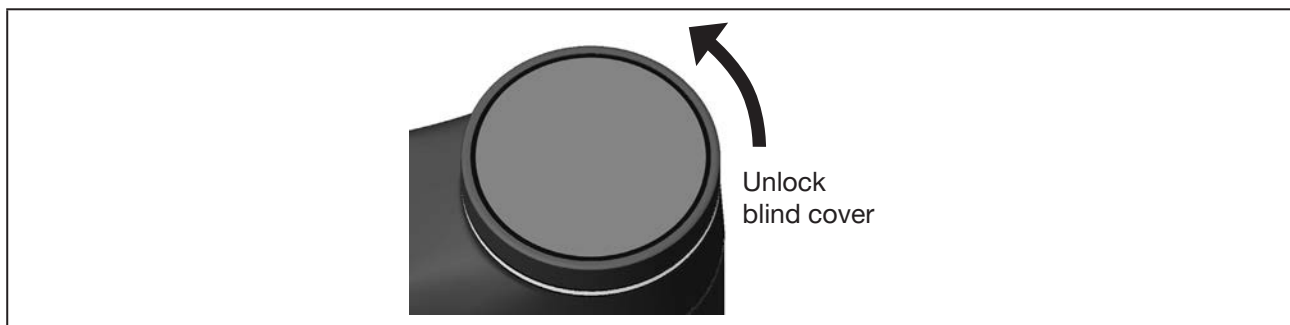

Image 34: Remove the blind cover from the actuator housing

→ To unlock the blind cover, turn it counterclockwise and remove.

→ To adjust the valve, use an Allen key with 3 mm AF.

NOTE!

Maximum torque 2 Nm.
Exceeding this torque value upon reaching the end position of the valve may damage the mechanical manual override mechanism.

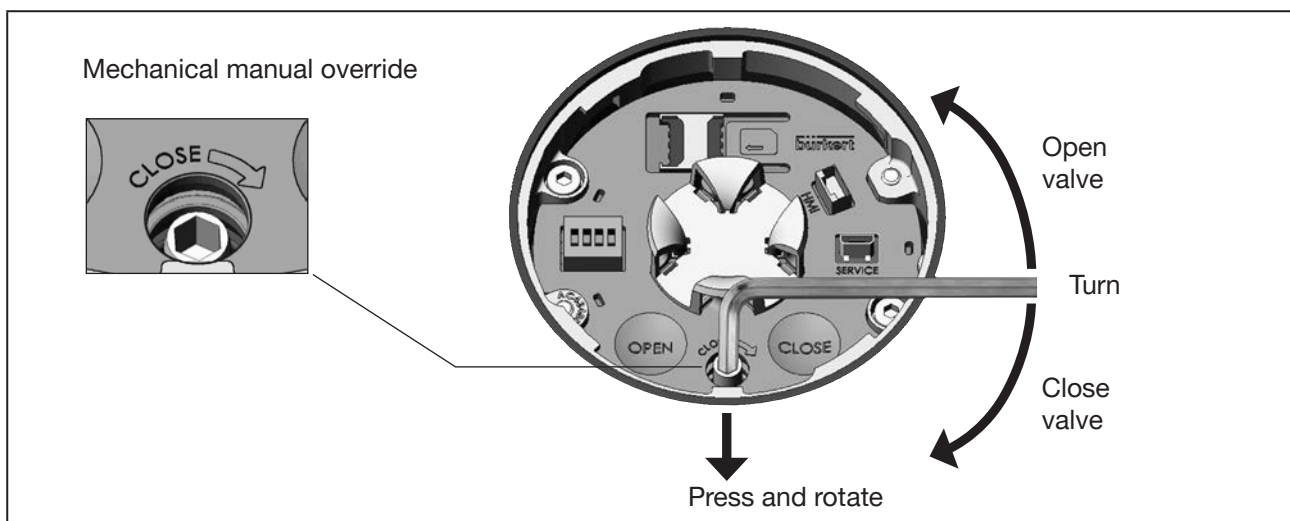

Image 35: Mechanical manual override

→ Apply light pressure to lock the mechanical manual override mechanism into place while turning the Allen key at the same time (see “Image 35”).

→ Move the valve to the desired position.

⚠ Maximum torque 2 Nm.

Open (turn counterclockwise), close (turn clockwise).

The position indicator shows that the valve end positions have been reached (see “Image 36”).

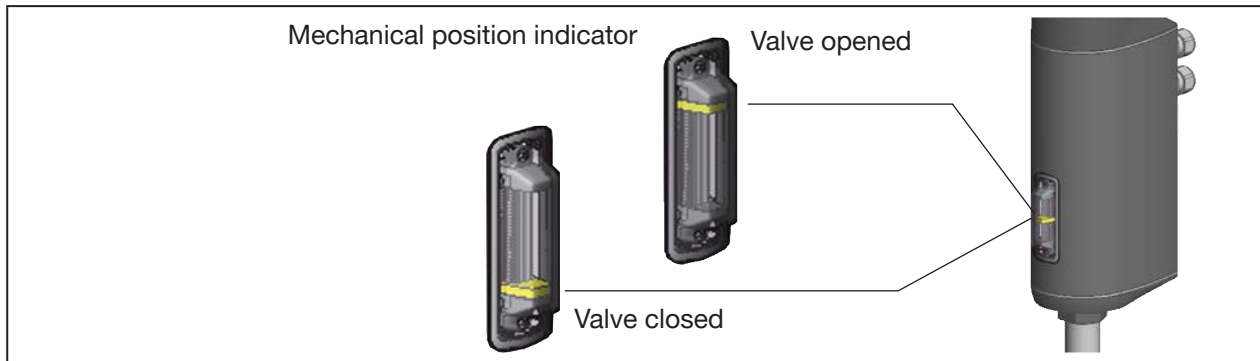

Image 36: Mechanical position indicator

→ Once the desired valve position is achieved, remove the Allen key.

The mechanical manual override mechanism will disengage automatically.

16 OPERATING STRUCTURE AND FACTORY SETTING

The factory default settings are depicted in blue in the operating structure to the right of the menu.

- Examples: / Factory-enabled or selected menu options
 / Factory-disabled or unselected menu options
 2%, 10 sec, ... Factory-set values

16.1 Operating structure of the configuration area

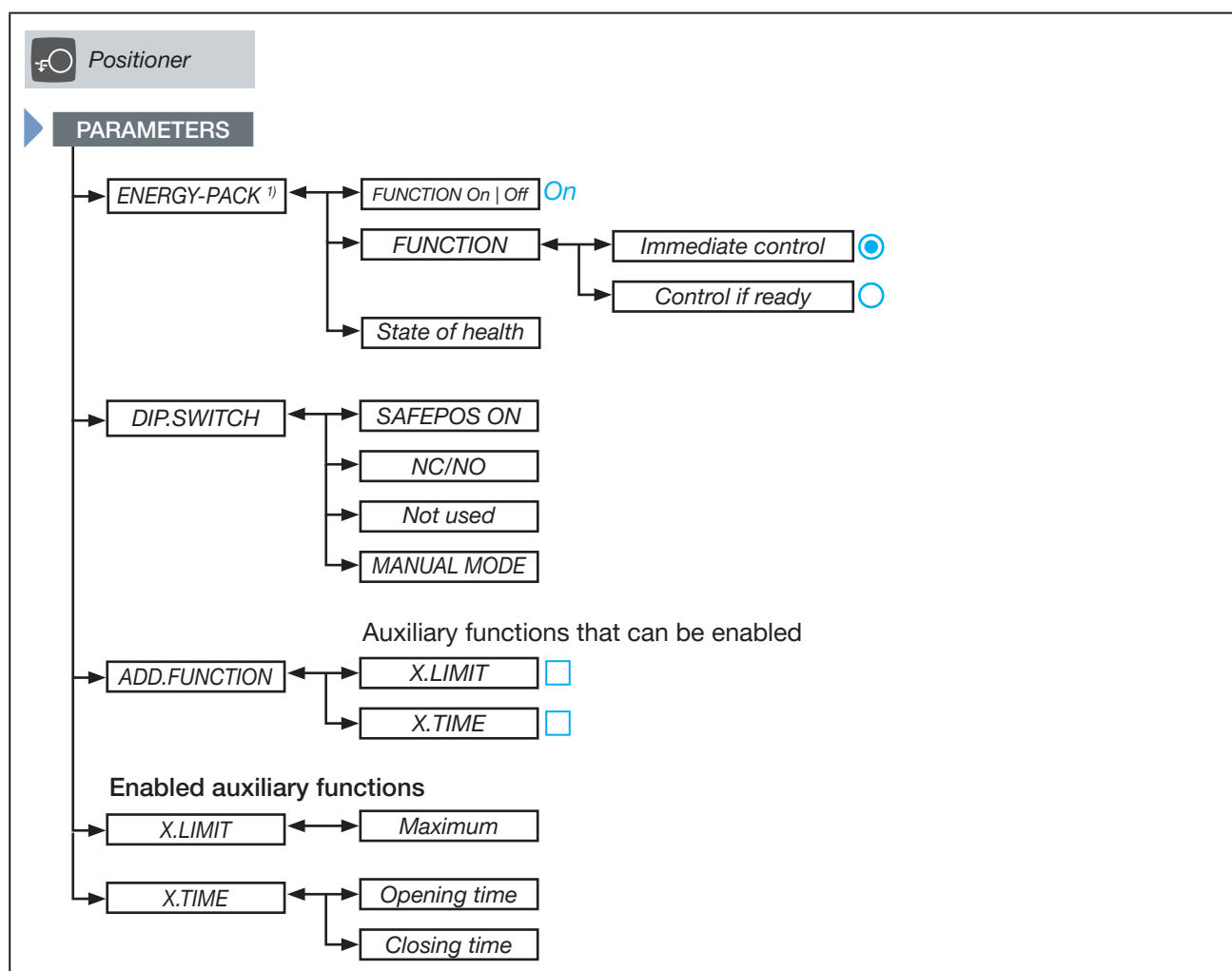

Image 37: Operating structure – 1-a, "Positioner" configuration area

1) Only available in devices with energy storage system SAFEPOS energy-pack (option).

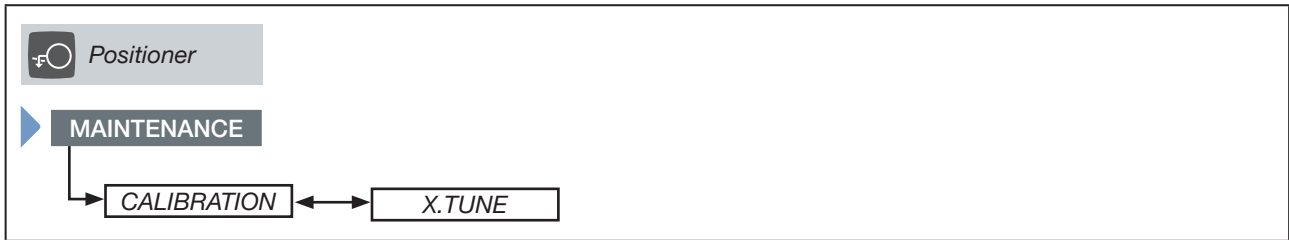

Image 38: Operating structure – 1-b, positioner maintenance

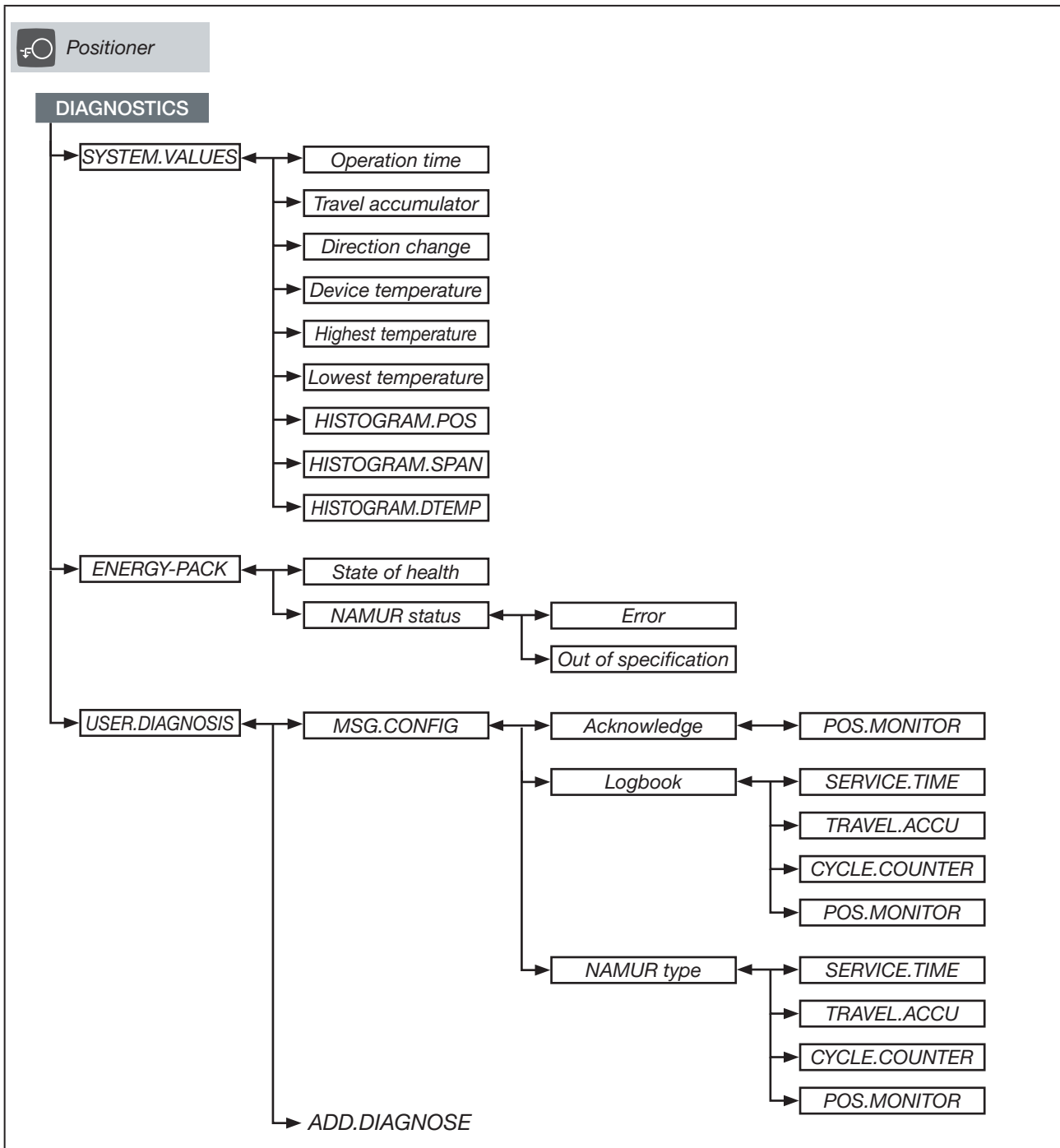

Image 39: Operating structure – 1-c, positioner diagnostics

MAN 1000295593 EN Version: H Status: RL (released | freigegeben) printed: 06.08.2021

MAN 1000295593 EN Version: H Status: RL (released | freigegeben) printed: 06.08.2021

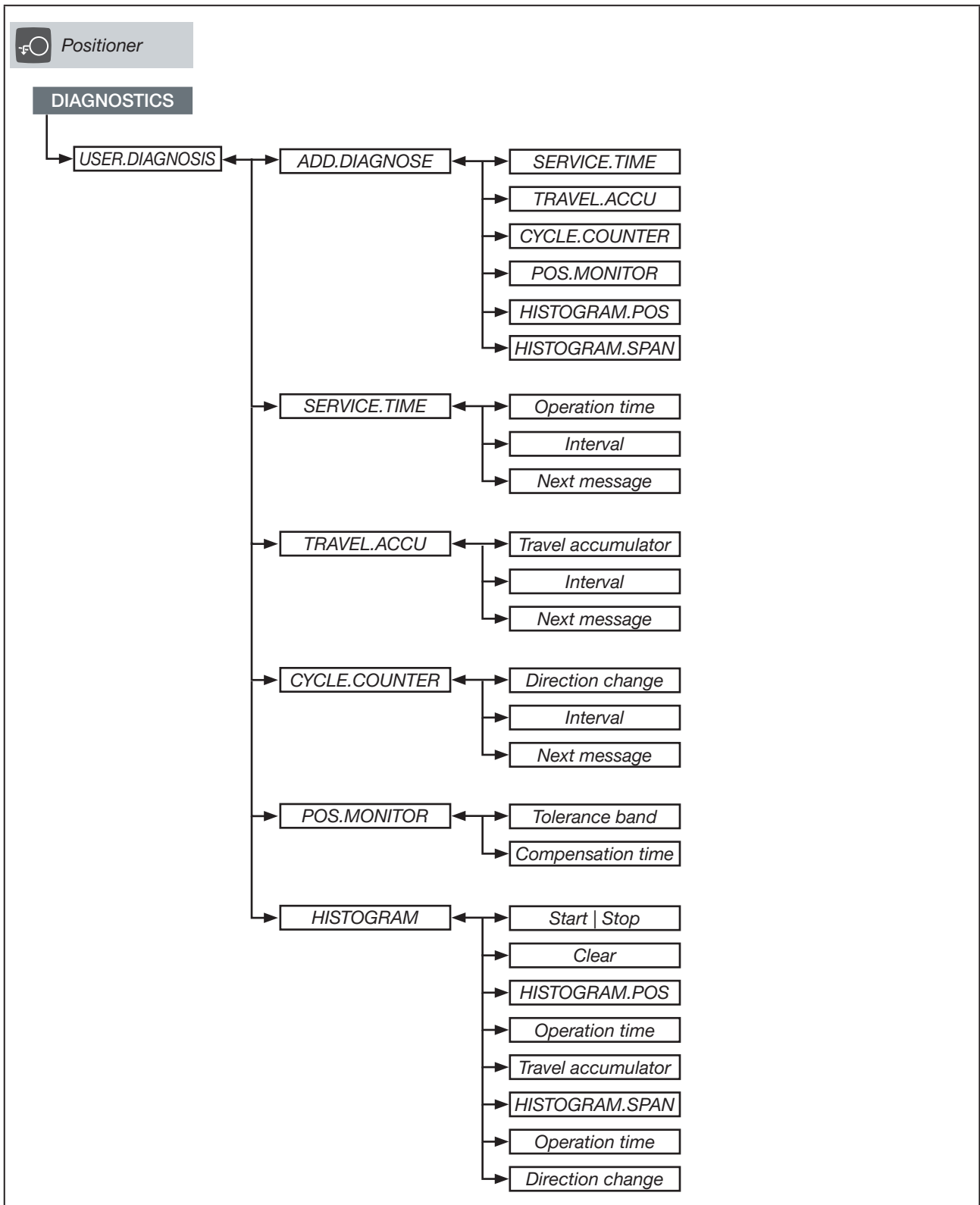

Image 40: Operating structure – 1-d, positioner diagnostics

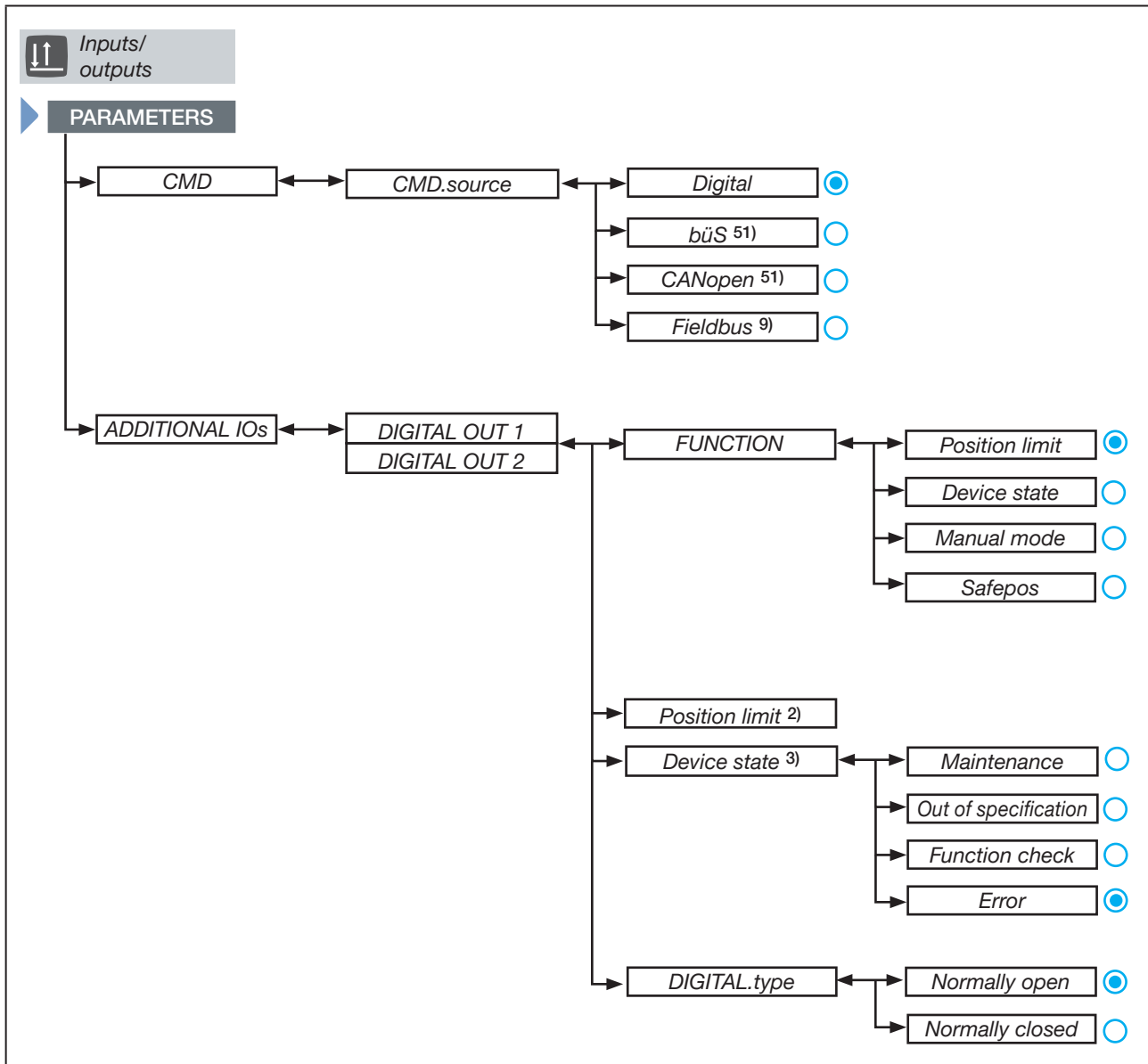

Image 41: Operating structure – 2-a, “Inputs/outputs” configuration area

2) Only available when selected in submenu **Source** → **Internal** and in **FUNCTION** → **Position limit**.

3) Only available when selected in submenu **Source** → **Internal** and in **FUNCTION** → **Device state**.

9) Only available in devices with gateway option.

51) Only available in devices with corresponding protocol

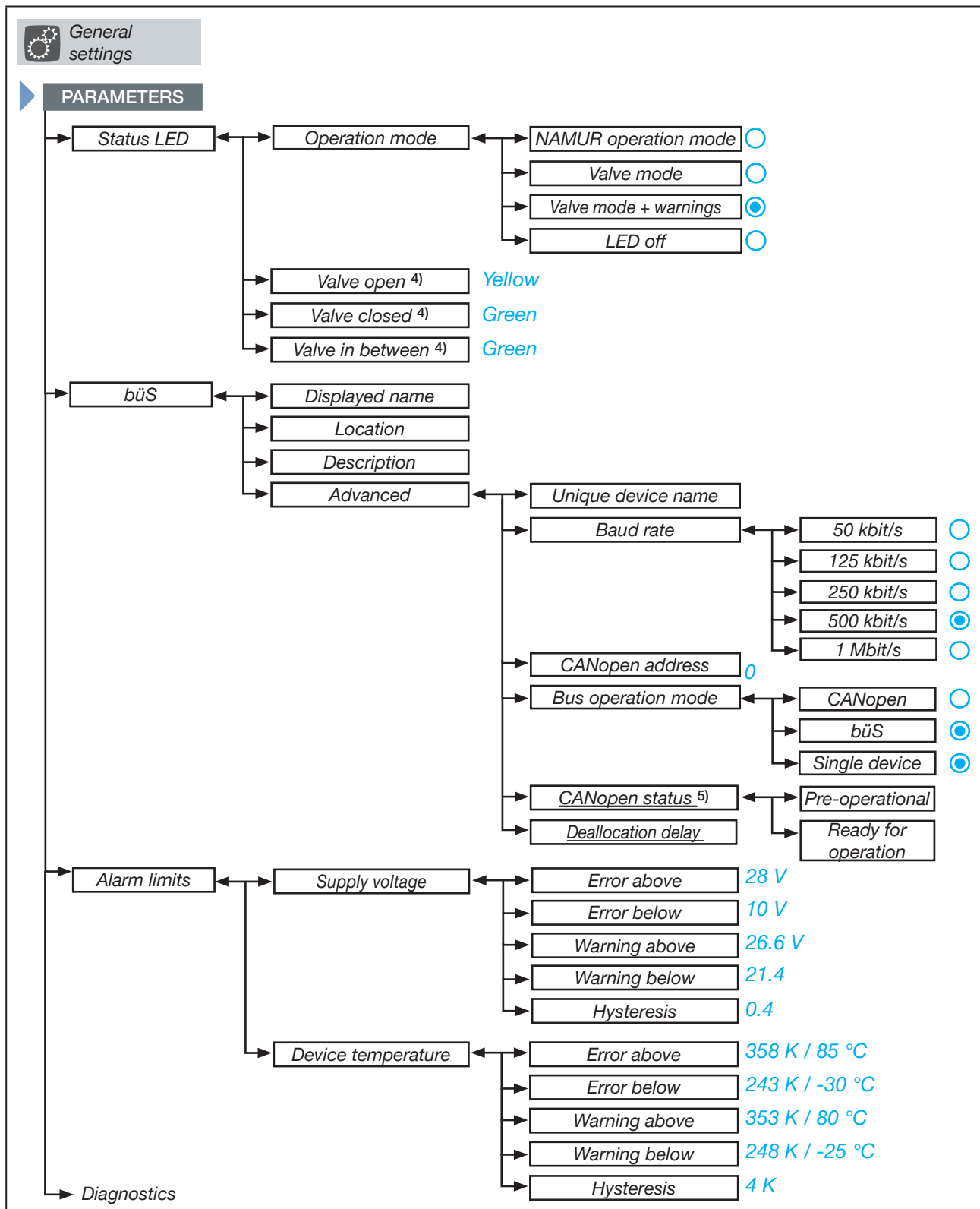

Image 42: Operating structure – 3-a, configuration area “General settings”

4) Only available if selected in the menu **Operation mode** → **Valve mode** or **Valve mode+warnings**.5) Only available if selected in the menu **Bus operation mode** → **CANopen**.

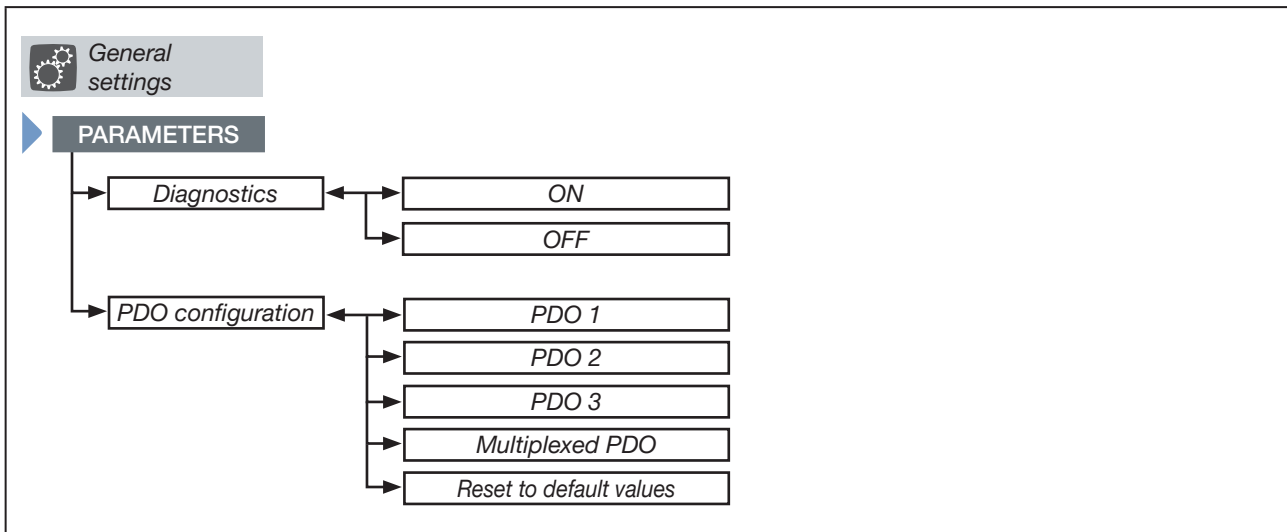

Image 43: Operating structure – 3-b, configuration area “General settings”

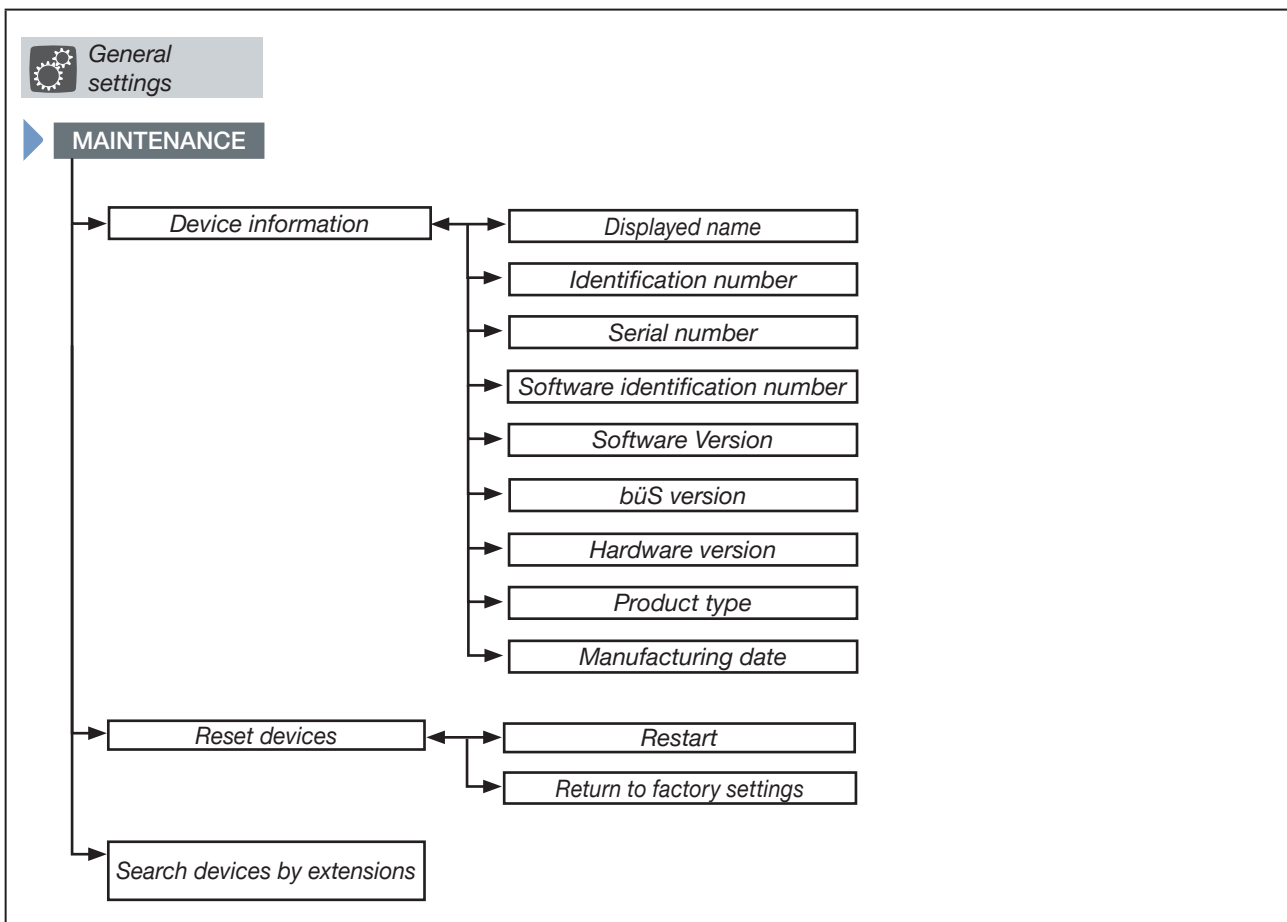

Image 44: Operating structure – 3-c, general settings maintenance

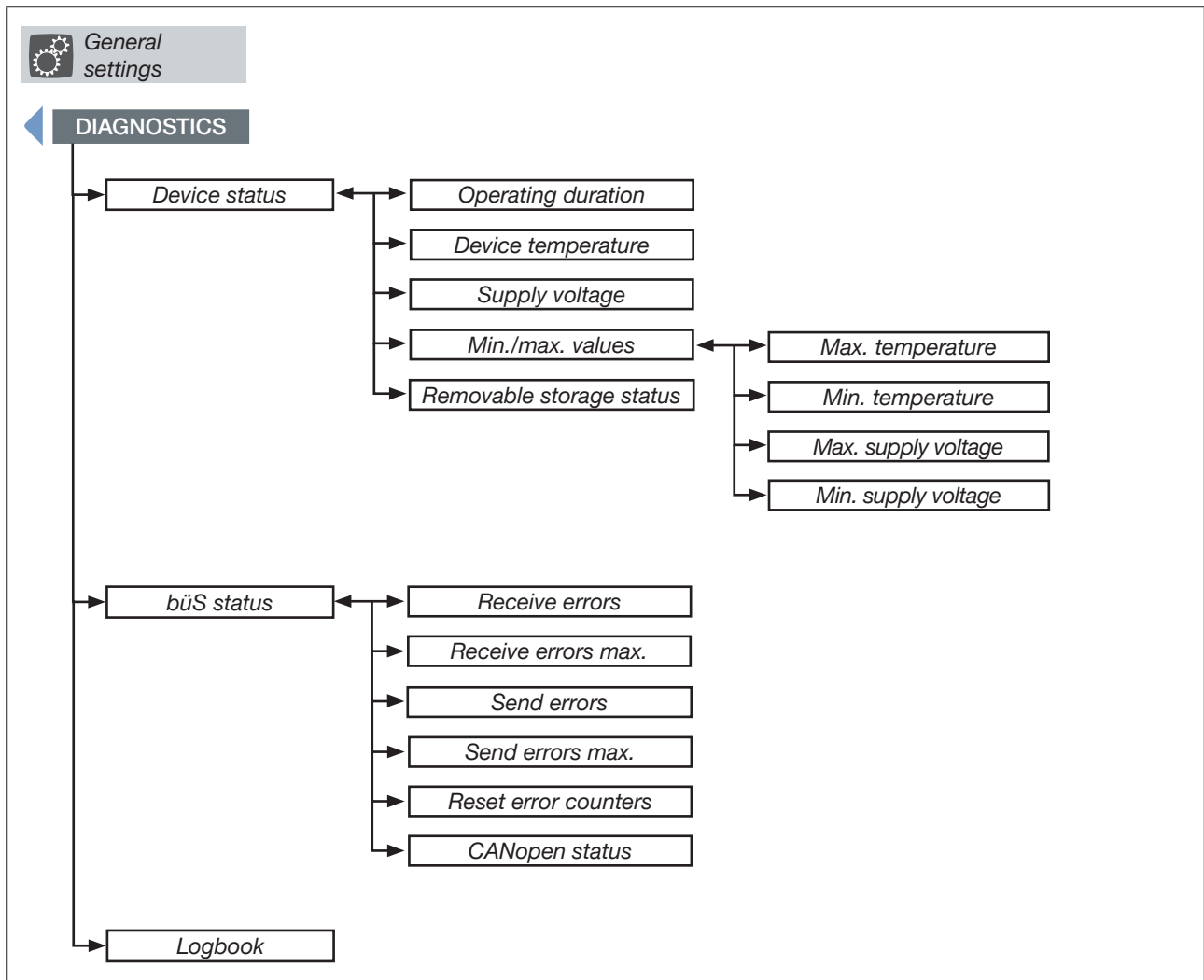

Image 45: Operating structure – 3-d, general settings diagnostics

17 INDUSTRIAL ETHERNET

To allow connection to an Ethernet network, the electromotive valve with integrated fieldbus gateway is optionally available.

Supported fieldbus protocols: Ethernet/IP, PROFINET, Modbus TCP.

17.1 Fieldbus gateway description

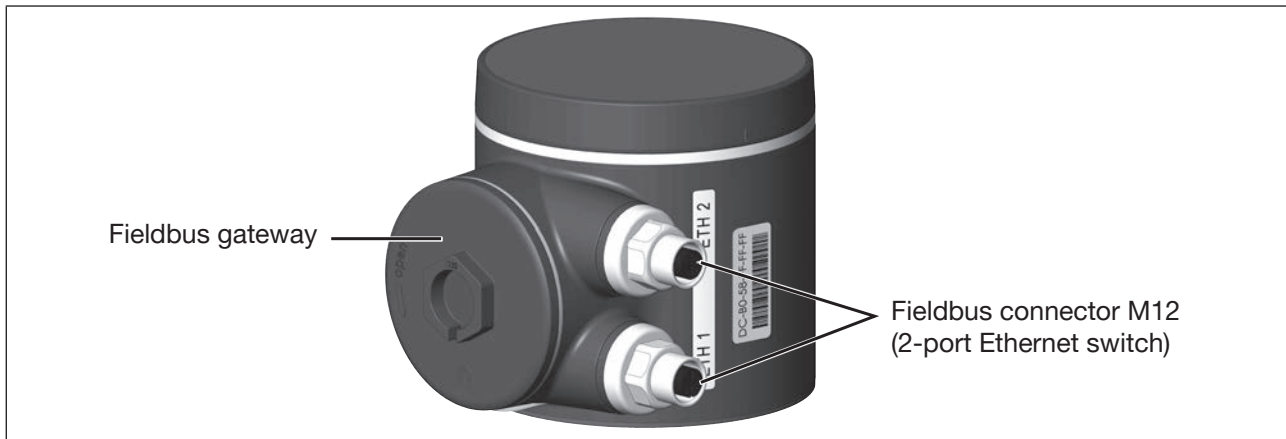

Image 46: *Fieldbus gateway*

17.1.1 Access to büS service interface

The büS service interface is located inside the Fieldbus gateway.

To access it, turn the cover counterclockwise.

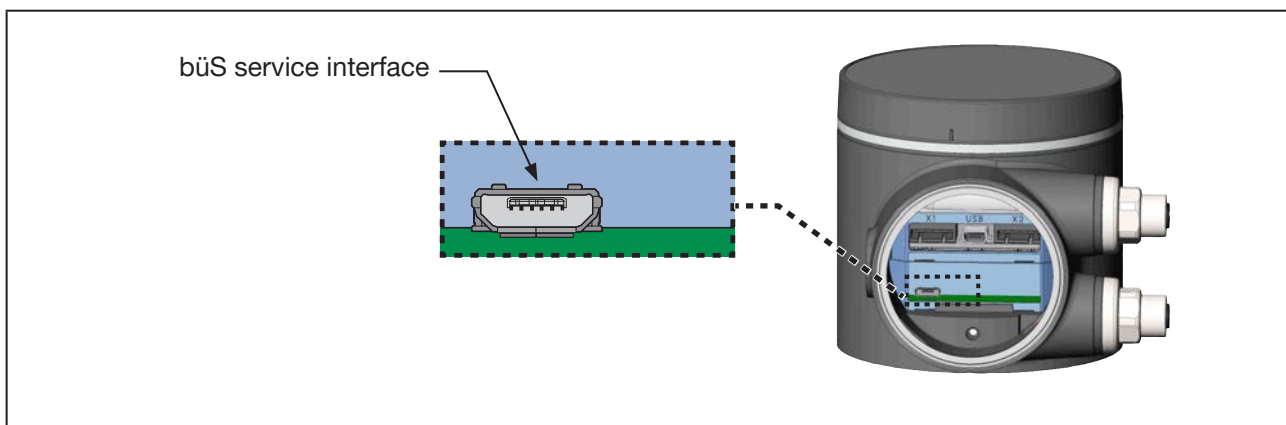

Image 47: *büS service interface with Fieldbus gateway variant*



For electrical connection of Fieldbus gateway:
see chapter [10.3](#) in manual [3360/61](#).

17.1.2 LEDs for indicating network connection status

The LEDs for indicating network connection status are located inside the fieldbus gateway.

To access it, turn the cover counterclockwise.

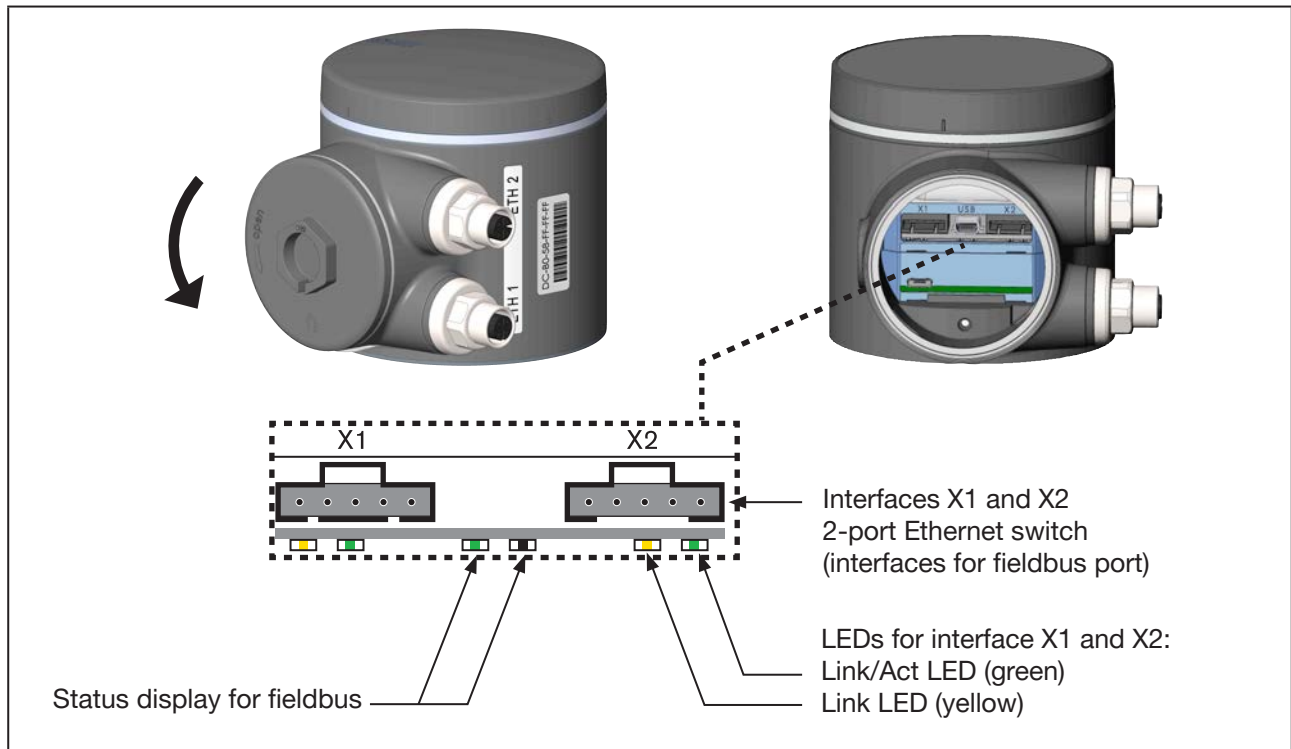

Image 48: LEDs for indicating network connection status

LED status		Fault description/cause	Measure
Link/Act LED (green)	Active	Rapid flashing: Connection with overriding protocol layer EtherNet/IP has been established. Data are being transmitted. Slow flashing: There is no connection to the protocol layer. This is normally the case for approx. 20 seconds after restarting.	
	Not active	No connection to the network available.	Check cable.
Link LED (yellow)	Active	Connection to network active.	-
	Not active	No connection to the network available.	Check cable.

Table 22: LED status indicators of interfaces X1 and X2 for EtherNet/IP (fieldbus port)

17.2 Technical data Industrial Ethernet

17.2.1 PROFINET IO specifications

Topology recognition	LLDP, SNMP V1, MIB2, Physical Device
Minimum cycle time	10 ms
IRT	not supported
MRP media redundancy	MRP client is supported
Other supported functions	DCP, VLAN Priority Tagging, Shared Device
Transmission speed	100 MBit/s
Data transport layer	Ethernet II, IEEE 802.3
PROFINET IO specification	V2.3
(AR) Application Relations	The device can simultaneously process up to 2 IO-ARs, 1 Supervisor AR and 1 Supervisor-DA AR.

17.2.2 EtherNet/IP specifications

Pre-defined standard objects	Identity Object (0x01) Message Router Object (0x02) Assembly Object (0x04) Connection Manager (0x06) DLR Object (0x47) QoS Object (0x48) TCP/IP Interface Object (0xF5) Ethernet Link Object (0xF6)
DHCP	supported
BOOTP	supported
Transmission speed	10 and 100 MBit/s
Duplex modes	Half duplex, full duplex, auto-negotiation
MDI modes	MDI, MDI-X, Auto-MDIX
Data transport layer	Ethernet II, IEEE 802.3
Address Conflict Detection (ACD)	supported
DLR (ring topology)	supported
Integrated switch	supported
CIP reset service	Identity Object Reset Service types 0 and 1

17.2.3 Modbus TCP specifications

Modbus function codes	1, 2, 3, 4, 6, 15, 16, 23
Operation mode	Message mode: Server
Transmission speed	10 and 100 MBit/s
Data transport layer	Ethernet II, IEEE 802.3

17.3 Projecting via fieldbus

For project planning, you need the suitable start-up file for the respective fieldbus protocol.

Fieldbus	Start-up file
EtherNet/IP	EDS file
PROFINET	GSDML file
Modbus TCP	not required

The start-up files required for the respective project planning software and their description are available on the Internet.



Download at:

www.burkert.com / Type 3320, 3321 / Downloads "Software" / Initiation Files

Please refer to the documentation of your project design software for instructions regarding the installation of the start-up files.

17.3.1 Setting the Ethernet parameters for EtherNet/IP, PROFINET, Modbus TCP



With Modbus TCP, it is essential to set the Ethernet parameters.



Setting option:

with the Bürkert Communicator software or with the web server.

Settings are created on the PC using the bÜS service interface and the Bürkert Communicator software. It requires the USB bÜS interface set available as an accessory.

To set the Ethernet parameters, you must switch to the detailed view "Parameters for Industrial Communication".

How to switch to detailed view:

→ For setting with Bürkert Communicator, select **Industrial Communication** in the navigation area.

✓ You are now in the "Parameter" detailed view.



The Ethernet parameters can only be set when the corresponding fieldbus protocol has been selected. **Parameter** → **Protocol settings** → **Protocol** → Select protocol.

Setting the Ethernet parameters:

→ **Select Protocol settings.**

→ Select **Protocol** and set the desired fieldbus protocol.

Settings:

→ **Select IP settings** and create settings.

- **DNS compatible name** can only be set with PROFINET. Factory default setting: do not discard
- **Static IP address** Factory default setting: 192.168.0.100

- **Network mask** Factory default setting: 255.255.255.0
- **Standard gateway** Factory default setting: 192.168.0.1.



With PROFINET, the factory default setting for the standard gateway is 0.0.0.0.

Setting for EtherNet/IP fieldbus protocol:

→ **Select IP settings.**

→ Select **IP operation mode** and set the desired operation mode. Factory default setting: **Static IP address.**

✓ You have set the Ethernet parameters to connect the device to the PLC network.

The complete Industrial Communication menu is described in the separate software manual.



Download at:

www.burkert.com / Type 3320, 3321 / Downloads "Operating instructions" / Software manual Type 3320...

17.4 Web server

The configuration of the Ethernet participant, required to connect to the network, can be run with a web server.

17.4.1 Connecting to the web server

→ Only with PROFINET: Assign IP addresses and DNS-compatible name with a suitable start-up tool for PROFINET attachments.

→ Set IP address in the PC network card.

IP address: 192.168.0.xxx

For xxx, enter any numerical value other than 100
(100 is occupied by the IP address of the Ethernet participant by default).

→ Connect the PC with a network cable to the Ethernet participant.

17.4.2 Access to the web server

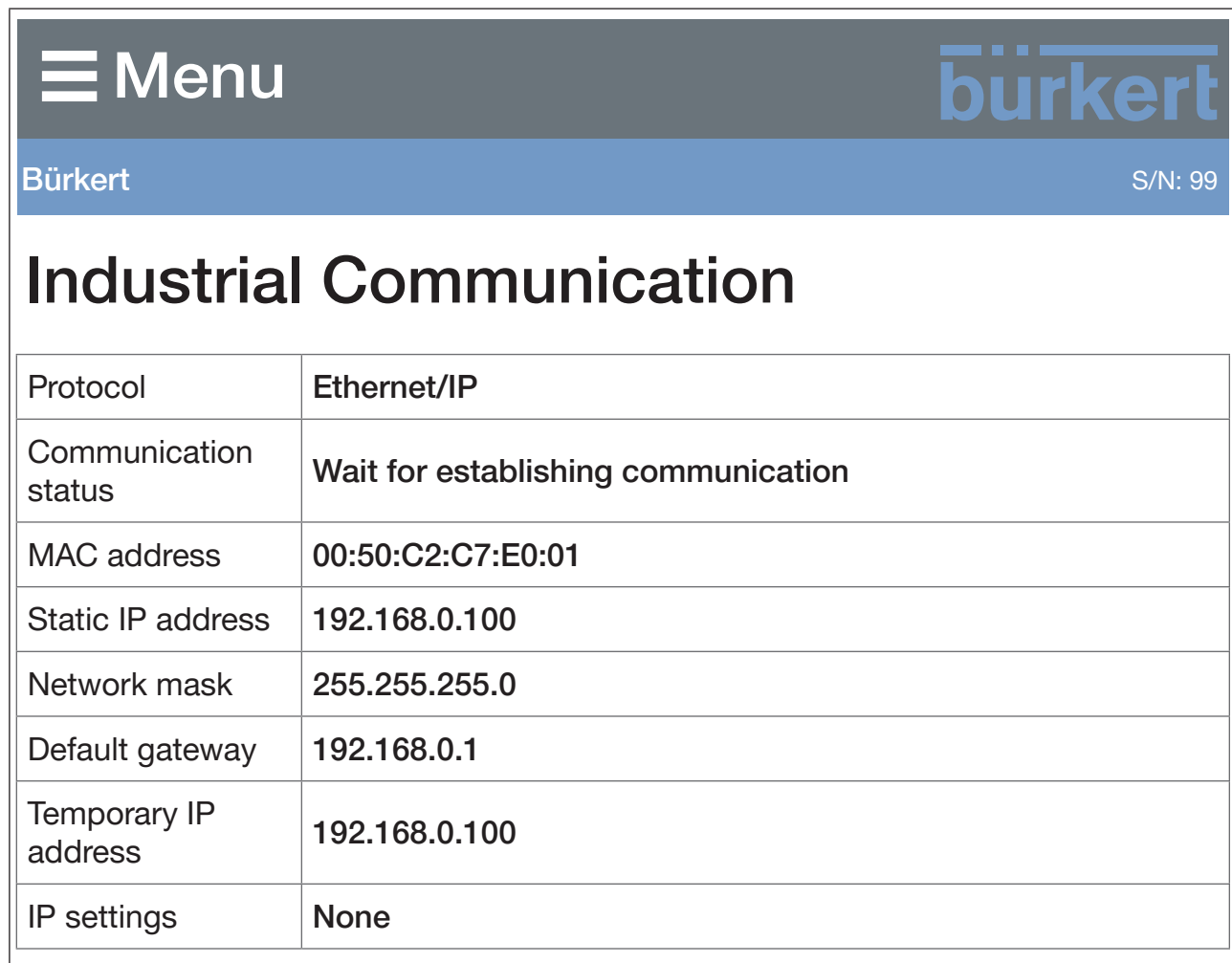

The screenshot shows a web browser interface for the Bürkert web server. At the top left is a 'Menu' button with a hamburger icon. At the top right is the 'bürkert' logo. Below the logo, the text 'Bürkert' is displayed on the left and 'S/N: 99' on the right. The main heading is 'Industrial Communication'. Below this is a table with the following data:

Protocol	Ethernet/IP
Communication status	Wait for establishing communication
MAC address	00:50:C2:C7:E0:01
Static IP address	192.168.0.100
Network mask	255.255.255.0
Default gateway	192.168.0.1
Temporary IP address	192.168.0.100
IP settings	None

Image 49: Access to the web server via the default IP

With EtherNet/IP, DHCP or BOOTP can also be set (NOT by default).
In this process, the IP address is acquired from a DHCP server.

→ Open an internet browser.

→ Enter default IP **192.168.0.100**.

(On EtherNet/IP devices, the IP address is assigned by a DHCP server. If no address is assigned via DHCP within 1 minute, the device uses the default IP 192.168.0.100.)

The software for configuring the Ethernet participant is now available on the PC.



Configuration of multiple devices:

On delivery, all devices have the same IP address (192.168.0.100 or 0.0.0.0 for PROFINET). So that the device can be identified for configuration, only 1 unconfigured device may be on the network.

- ▶ Successively connect the devices (Ethernet participants) to the network individually and configure them.

17.4.3 Configuring Ethernet participants

Logging onto the system:

→ Enter your user name and password .

Username: **admin**

Password: **admin**

☰

Menu



Bürkert
S/N: 99

User login

User name	admin
User password	admin x

Image 50: Logging onto the system

Configuration:

- Enter the device name and IP address for the Ethernet participant.
The device name assigned here is used later during project planning (e.g. under STEP 7).
- Confirm with **Commit changes**.
- Conduct a power reset of the Ethernet participant to incorporate the changed parameters.
- Restart the device with **Restart device**.

Menu		bürkert
Bürkert		S/N: 99
<h2>Network configuration</h2>		
Protocol	EtherNet/IP	▼
Static IP address	192.168.0.100	
Network mask	255.255.255.0	
Default gateway	192.168.0.1	
IP settings	None	▼
Commit changes		Restart device

Image 51: Configuring Ethernet participants

17.5 Advanced functionalities

17.5.1 Object route function

The object route function grants access to all objects in the system. Access requires the object, with index and sub-index, and the address of the device/module to be specified. Then the value can be read back.

The interface for this is described in the additional instructions.



Download at:
www.burkert.com / Type ME23 / Fieldbus description

The following objects allow additional control and monitoring.

17.5.2 Device Status NAMUR NE 107

Name		Description				Access type	
Device status NAMUR NE 107		Corresponds to device status of Type 3323, 3324, 3325				RO	
Bit 7	Bit 6	Bit 5	Bit 4	Bit 3	Bit 2	Bit 1	Bit 0
reserved	reserved	NAMUR operation mode: 0 – AUTOMATIC operating state 1 – MANUAL operating state 2 – flashing		NAMUR status: 0 – normal 1 – diagnostics active 2 – maintenance required 3 – outside of specification 4 – warning 5 – error			

Table 23: Device Status NAMUR NE 107

17.5.3 bÜS Control Object

Name	Description	Access type
Control mode*	Byte 0: defines device behaviour and communication with the connected devices. It can thus be determined when the device begins transmitting process data. Byte 1: defines device behaviour when a participant fails.	RW
Control Word**	Byte 0: Address of the device to be controlled. Byte 1: Note (device) management as per CANopen specification.	RW

*	Byte 1	Byte 0
	0: reserved	0: AUTOMATIC operating state (bÜS default)
	1: Do not remove assignment to missing participant	1: enter for operation with KOM 2: enter for operation with PLC
	Byte 3	Byte 2
	Reserved	Reserved
**	Byte 1	Byte 0
	0x81: Node reset (device restart)	0xFF: All participants
	Byte 3	Byte 2
	Reserved	Reserved

Table 24: bÜS Control Object

18 MAINTENANCE, TROUBLESHOOTING

18.1 Safety instructions



DANGER!

Risk of injury from high pressure in the device or system.

- ▶ Switch off the pressure before working on the device or system. Vent or empty the lines.

Risk of injury due to electric shock.

- ▶ Before working on the device or system, switch off the power supply. Secure it against reactivation.
- ▶ Observe the applicable accident prevention and safety regulations for electrical devices!



WARNING!

Risk of injury due to improper maintenance work.

- ▶ Maintenance may be carried out only by trained specialist technicians and with the appropriate tools.
- ▶ Secure the system to prevent unintentional activation.
- ▶ Ensure a controlled restart after maintenance is completed.

18.2 Maintenance

The maintenance work is described in the separate service instructions. These instructions can be found on our homepage at: country.burkert.com → Type 3320, 3321.

18.2.1 Actuator

When used in accordance with these operating instructions, the electromotive actuator is maintenance-free.

18.2.2 Wearing parts of the valve

Parts which are subject to natural wear are:

- Seals
- Swivel plate
- Valve seat

→ If there is a leak, replace the respective wearing part with a corresponding spare part. (For spare part sets and assembly tools see chapter “22.2 Spare parts”).

Replacement of the wearing parts is described in the separate service instructions.

These instructions can be found on our homepage at: country.burkert.com → Type 3320, 3321.

18.2.3 Visual inspection

According to the usage conditions, perform regular visual inspections:

- Check medium ports for tightness.
- Check relief bore on the pipe for leaks.

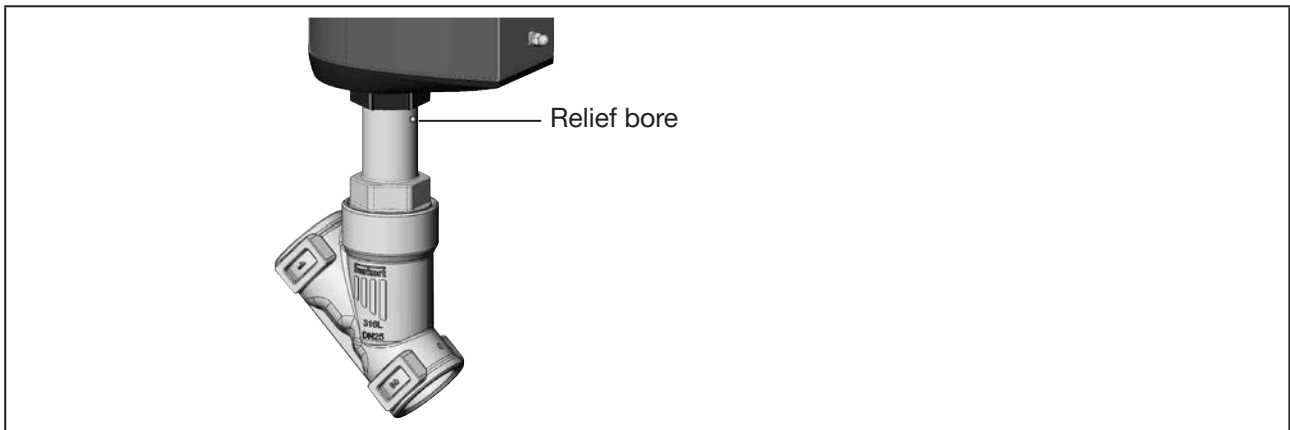

Image 52: Relief bore

18.2.4 Replacing the energy storage SAFEPOS energy-pack

Replacement of the SAFEPOS energy-pack is described in chapter [“7.2.3 Replacing the SAFEPOS energy-pack”](#).

18.2.5 Maintenance notifications

Maintenance notifications are displayed in the following LED operation modes:

- Valve mode + warnings (factory pre-set).
The LED light ring alternately flashes blue and the colour indicating the valve position.
- NAMUR operation mode.
The LED light ring glows blue.



If the LED operation mode is set to “valve mode”, maintenance notifications are not displayed.

Notification	Device behaviour	Measure
The remaining service life of the energy pack is around 25%! The energy pack needs to be replaced soon.	Maintenance notification.	The SAFEPOS energy-pack must be promptly replaced before the end of its service life.

Table 25: Maintenance notifications

18.3 Troubleshooting

18.3.1 Notifications on device status “Out of specification”

Notifications on device status “Out of specification” are displayed in the following LED operation modes:

- Valve mode + warnings (factory pre-set).
The LED light ring alternately flashes yellow and the colour indicating the valve position.
- NAMUR operation mode.
The LED light ring glows yellow.



In LED operation mode “valve mode”, notifications on the device status “Out of specification” are not displayed.

Notification	Description	Device behaviour	Measure
Motor temperature is high.	Increased friction in the actuator train.	Notification “Out of specification”	Contact Bürkert Service if problem persists.
Temperature warning limit exceeded.	Ambient temperature too high or increased friction in actuator train.	Notification “Out of specification”	Reduce ambient temperature. Contact Bürkert Service if problem persists.
Temperature warning limit undershot.	Ambient temperature is too low.	Notification “Out of specification”	Increase ambient temperature
Voltage warning limit exceeded.	Supply voltage is too high.	Notification “Out of specification”	Check supply voltage.
Voltage warning limit undershot.	Supply voltage is too low.		

Table 26: Notifications on device status “Out of specification”

18.3.2 Error notifications

Device error notifications are displayed as follows:

- Valve mode
The LED light ring alternately flashes red and the colour indicating the valve position.
- Valve mode + warnings (factory pre-set).
The LED light ring alternately flashes red and the colour indicating the valve position.
- NAMUR operation mode.
The LED light ring glows red.

Notification	Description	Device behaviour	Measure
Motor temperature is too high. Motor is moving to the safety position.	Too much friction in the actuator train for operation.	Error notification. Actuator is moving to the safety position.	Contact Bürkert service.
Motor temperature is too high. Motor is idling to prevent thermal damage.	Too much friction in the actuator train for operation.	Error notification. Motor switches off. Actuator remains in place. MANUAL operating state not possible.	Contact Bürkert service.
Excess temperature detected.	Device temperature too high for operation.	Error notification. Actuator is moving to the safety position. MANUAL operating state possible.	Reduce ambient temperature. Contact Bürkert Service if problem persists.
Low temperature detected.	Device temperature too low for operation.	Error notification. Actuator is moving to the safety position. MANUAL operating state possible.	Increase ambient temperature.
Overtoltage detected.	Supply voltage too high for device operation.	Error notification. Actuator is moving to the safety position. MANUAL operating state possible.	Check supply voltage.
Undervoltage detected.	Supply voltage failure, or supply voltage too low for device operation.	Error notification. Actuator is moving to the safety position. MANUAL operating state not possible.	Check supply voltage. Contact Bürkert Service if problem persists.
Motor current too high.	Increased friction in the actuator train or incorrect detection of the end positions.	Error notification. Motor switches off. Actuator remains in place. MANUAL operating state not possible.	Carry out the X.TUNE function. Contact Bürkert Service if problem persists.
Motor peak current too high.	Increased friction in the actuator train or incorrect detection of the end positions.		

Notification	Description	Device behaviour	Measure
Internal error: Reverberation sensor signal failure.	Signal failure of the position sensor.	Error notification. Actuator is moving to safety position. MANUAL operating state not possible.	Contact Bürkert service.
Internal error: ...	Internal error in the device.	Error notification. Actuator is moving to the safety position.	Contact Bürkert service.
Persistent storage not usable: Defective or not available.	Reading or writing error of internal data storage EEPROM.	Error notification. Actuator is moving to the safety position	Restart the device. Contact Bürkert Service if problem persists.
BueS event: producer(s) not found.	Assigned external büS producer cannot be found.	Error notification. Actuator is moving to the safety position.	Check signal to büS partner.
BueS event: bus connection lost/not available.	büS network cannot be found.	Error notification. Actuator is moving to the safety position.	Check büS network.
BueS event: producer is not operational.	Producer not operational in this state.	Error notification. Actuator is moving to the safety position.	Check büS producer.
BueS event: a device is using the same address.	Another büS participant is using the same address.	Error notification. Actuator is moving to the safety position.	Assign a unique address to the device and büS participant.
External CMD not assigned.	"EXTERNAL" is set as the source of the input signal. Missing assignment of the external büS partner.	Error notification. Actuator is moving to the safety position.	Assign external büS partner or set "Internal" or "Gateway" as the source for the input signal. Setting the input signal: Select "Inputs/outputs" in the configuration area.
External ExtError not assigned.			
External DigitalOut1 not assigned.			
External DigitalOut2 not assigned.			
Energy storage must be replaced.	Storage capacity of the energy storage is too low. Assumption of the safety position cannot be guaranteed.	Error notification. Actuator is moving to the safety position.	Replace energy storage SAFEPOS energy-pack.
No energy storage available.	Energy storage SAFEPOS energy-pack not detected.	Error notification. Actuator is moving to the safety position.	Check whether the SAFEPOS energy-pack is correctly installed.

Table 27: Error notifications

19 CANopen



For electrical installation of devices with CANopen network: refer to chapter “[10.1.4 X3 – M12 circular plug, 4-pin or 5-pin, operating voltage and bÜS/ CANopen communication](#)” on page 40 for description.

19.1 Projecting via fieldbus

For project planning, you need an eds file as a start-up file for CANopen.
The eds file and the associated description are available on the Internet.



Download at:
www.burkert.com / Type 3360, 3361 / Downloads “Software” / Initiation Files

Please refer to the documentation of your project design software for instructions regarding the installation of the start-up files.

19.2 CANopen network configuration

Instructions for the network configuration based on the CANopen protocol are available on the Internet.



Download at:
www.burkert.com / Type 3360, 3361 / Downloads “Operating instructions” / “Software instructions | CANopen network configuration”

20 bÜS

Definition: The term “bÜS” (Bürkert system bus) stands for the communication bus developed by Bürkert, based on the CANopen protocol.



For electrical installation of devices with bÜS network: refer to chapter “[10.1.4 X3 – M12 circular plug, 4-pin or 5-pin, operating voltage and bÜS/ CANopen communication](#)” on page 40 for description.

20.1 Cabling of bÜS networks



Additional information about cabling for bÜS networks is available at manual „Cabling Guide for bÜS/EDIP“ at country.burkert.com

20.2 Configuration of bÜS networks

Additional information about the configuration of bÜS networks can be found on the Internet.



Download at:
www.burkert.com / Type 8922 / Downloads / User Manuals / Software instructions Typ8922, MExx | Software of f(x) configuration

21 CLEANING

The use of alkaline cleaning agents is not permitted for cleaning the surface of the device.

22 ACCESSORIES, REPLACEMENT PARTS



CAUTION!

Risk of injury and/or damage due to incorrect parts.

Incorrect accessories and unsuitable spare parts may cause injuries and damage the device and the area around it.

- ▶ Use only original accessories and original spare parts from Bürkert.



Additional information about cabling for bÜS networks is available at manual „Cabling Guide for bÜS/EDIP“ at country.burkert.com

Accessories	Order number
Connection cable with M12 circular socket, 4-pin, (length 5 m) for operating voltage (without communication)	918038
Connection cable with M12 circular socket, 8-pin, (length 2 m) for input and output signals	919061
USB bÜS interface set:	
USB bÜS interface set 1 (includes power supply unit, bÜS stick, terminating resistor, Y-distributor, 0.7 m cable with M12 plug)	772426
USB bÜS interface set 2 (includes bÜS stick, terminating resistor, Y-distributor, 0.7 m cable with M12 plug)	772551
bÜS adapter for bÜS service interface (M12 to micro-USB bÜS service interface)	773254
bÜS cable extensions of M12 circular plug to M12 circular socket	
Connection line, length 1 m	772404
Connection line, length 3 m	772405
Connection line, length 5 m	772406
Connection line, length 10 m	772407
Bürkert Communicator	Info at https://country.burkert.com/
SIM card	291773
Holding device for port connection DN15–DN20	693770
Holding device for port connection DN25–DN50	693771

Table 28: Accessories

22.1 Communication software

The PC software Bürkert Communicator is designed for communication with Bürkert devices.



A detailed description of the installation and operation of the PC software can be found in the associated operating instructions.

Download the software from: country.burkert.com

22.1.1 USB Interface

To communicate with the devices the PC requires a USB interface and the USB büS interface set available as an accessory (see “[Table 28: Accessories](#)”).

22.2 Spare parts

22.2.1 Spare parts for valves of Types 3320 and 3321

Spare parts for Type 3320 and 3321		Order number
SAFEPOS energy-pack		285834
Plastic blind cover		277881
Seal set for packing gland	Spindle ø 10 mm, DN15–DN40	309618
	Spindle ø 14 mm, DN50	309621
Seal set for packing gland (high-temperature variant up to +230 °C)	Spindle ø 10 mm, DN15–DN40	384013
	Spindle ø 14 mm, DN50	384015

Table 29: Spare parts for Type 3320 and 3321

22.2.2 Spare parts for angle seat valve Type 3320

Swivel plate set for Type 3320		
Includes: swivel plate, spring-type straight pin, graphite seal		
DN	Order number	
	PEEK	PTFE
15	On request	011134
20	On request	011171
25	On request	160737
32	On request	011208
40	On request	011209
50	On request	216431

Table 30: Swivel plate set for Type 3320

22.2.3 Spare parts for globe valve Type 3321

Swivel plate set for Type 3321		
Includes: swivel plate, spring-type straight pin, graphite seal		
DN	Order number	
	PEEK	PTFE
15	On request	149606
20	On request	011171
25	On request	160737
32	On request	011208
40	On request	011209

Swivel plate set for Type 3321		
Includes: swivel plate, spring-type straight pin, graphite seal		
DN	Order number	
	PEEK	PTFE
50	On request	216431

Table 31: Swivel plate set for Type 3321

22.2.4 Spare parts for valve seat set Type 3321

Valve seat set for Type 3321	
Includes: valve seat, graphite seal	
DN	Order number
15	262152
20	262157
25	262170
32	262174
40	262177
50	262179

Table 32: Valve seat set for Type 3321

22.3 Assembly tools

22.3.1 Installation tools for valves of Types 3320 and 3321

Modified socket wrench for packing gland (series-production status as of April 2012)			
Spindle \varnothing [mm]	Body DN	Width across flats	Order number
10	15...40	SW16	683221
14	50	SW24	683223

Table 33: Installation tools for Types 3320 and 3321

22.3.2 Accessories for Type 3321

Installation tool for replacing valve seat Type 3321	
DN	Order number
15	652604
20	652605
25	652606
32	652607
40	652608
50	652609

Table 34: Accessories for Type 3321

23 DISASSEMBLY

23.1 Safety instructions



DANGER!

Risk of injury due to high pressure and escaping medium.

If the device is pressurised while being disassembled, there is a risk of injury due to sudden depressurisation and medium discharge.

- ▶ Turn off the pressure before dismantling the device. Vent or empty the lines.



CAUTION!

Risk of injury due to heavy device.

During transportation or installation work, the device may fall down and cause injuries.

- ▶ Transport, install and remove heavy device with the aid of a second person only.
- ▶ Use suitable tools.

→ Disconnect the electrical connection.

→ Dismantle the device.

24 PACKAGING AND TRANSPORT



CAUTION!

Risk of injury due to heavy device.

During transportation or installation work, the device may fall down and cause injuries.

- ▶ Transport, install and remove heavy device with the aid of a second person only.
- ▶ Use suitable tools.

NOTE!

Transport damage.

Inadequately protected devices may be damaged during transport.

- Protect the device against moisture and dirt in shock-resistant packaging during transportation.
- Avoid exceeding or undercutting the permitted storage temperature.

25 STORAGE

NOTE!

Incorrect storage may damage the device.

- Store the device in a dry and dust-free location.
- Storage temperature: -40... +70 °C.

26 DISPOSAL

NOTE!

Damage to the environment caused by parts contaminated with media.

- Dispose of the device and packaging in an environmentally-friendly manner.
- Observe applicable disposal and environmental regulations.



Observe the national waste disposal regulations.

