



Pneumatically operated 2/2 way angle seat valve with stainless steel actuator

- Flow optimised stainless steel body with various line connections
- Trusted components for the longest life time
- Stainless steel actuator suitable for demanding environments
- Modular accessory program with stroke limitation and position feedback available

Product variants described in the data sheet may differ from the product presentation and description.

Can be combined with



Type 8640 ▶
Customized Pneumatic Systems Solutions for the Processing Industries



Type 8644 ▶
Remote Process Actuation Control System AirLINE



Type 8697 ▶
Pneumatic control for decentralised automation of ELEMENT process valves

Type description

The pneumatically operated angle seat valve with stainless steel actuators fulfils the demands of tough process environments. Unrivalled life time and sealing integrity is guaranteed by the trusted self-adjusting spindle sealing. The stainless steel actuator has been designed for tough applications. Laser welding ensures it is both cleanable and robust. With a ducted exhaust air port, the actuator can be operated isolated from the environment to guarantee an optimum life time and hygiene. High flow rates are attained with the optimised stainless steel angle seat body. As part of the Bürkert process valve range a large accessory program is available. All wetted parts comply with the EC Directive 1935/2004, variants with FDA conformity are available on request, also explosion proof variants are available.

Table of contents

1. General technical data	3
2. Circuit functions	4
3. Approvals	4
4. Materials	5
4.1. Chemical Resistance Chart – Bürkert resistApp.....	5
4.2. Material specifications	5
5. Dimensions	7
5.1. Angle seat valve Type 2060	7
5.2. Valve system On/Off ELEMENT Type 8801-YV.....	8
5.3. Body with threaded connection.....	9
5.4. Body with welded connection	10
5.5. Body with clamp connection	11
6. Performance specifications	12
6.1. Fluidic data	12
Overview of fluidic data for flow below seat (for gases, steam and liquids).....	12
Pilot pressure diagram with flow direction below seat (control function B, seat seal PTFE).....	13
Overview of fluidic data with flow above seat (for gases and steam).....	14
Pilot pressure diagram with flow direction above seat (control function A).....	14
6.2. Operating limits.....	15
Operating limits for medium temperature and operating pressure.....	15
Operating limits for ambient and medium temperature.....	16
Operating limits for optional versions	16
7. Product accessories	17
8. Networking and combination with other Bürkert products	18
9. Ordering information	19
9.1. Bürkert eShop – Easy ordering and quick delivery.....	19
9.2. Bürkert product filter.....	19
9.3. Ordering chart welded connection	19
Valve with flow direction below seat.....	19
Valves with flow direction above seat.....	22
9.4. Ordering chart accessories.....	22

1. General technical data

Product properties	
Dimensions	More detailed information can be found in the chapter “5. Dimensions” on page 7.
Material	More detailed information can be found in the chapter “4. Materials” on page 5.
Design	Angle seat valve
Port connection size	DN10...80; NPS ¾...NPS 3
Safety setting in case of power failure	Normally closed (control function A), normally open (control function B)
Flow direction	Flow to open (below seat), Flow to close (above seat)
Performance data	
Operating pressure	0...25 bar(g), Vacuum up to -0.9 bar (g) (option), see
Nominal pressure	PN25 (DIN EN 1333), Class 150 (DIN EN 1759)
Pilot pressure	2...10.5 bar(g), see “6.1. Fluidic data” on page 12
K_v value	3.8...140 m ³ /h
Media data	
Medium	Steam, water, neutral gases, alcohol, oils, fuels, hydraulic fluids, salt solution, alkali solutions, organic solvents
Medium temperature	-40...230 °C, see “6.2. Operating limits” on page 15
Viscosity	Max. 600 mm ² /s
Control medium	Air, neutral gases
Process/Port connection & communication	
Port Connections¹⁾	
Threaded connection	G (DIN ISO 228 - 1) NPT (ASME B 1.20.1) Rc (ISO 7 - 1)
Welded connection	DIN EN ISO 1127/ISO 4200/DIN 11866 B DIN 11850 2/DIN 11866 A ASME BPE/DIN 11866 C SMS 3008
Clamp connection	DIN 32676 B (pipe ISO 4200) DIN 32676 A (pipe DIN 11850 2) ASME BPE
Pilot air port	
Actuator size Ø 50(D)...130(P)	Thread G ½
Actuator size Ø 32 (B)	Thread M5
Approvals and certificates	
Conformity	Food contact 1935/2004(EG), FDA Drinking water Pressure Equipment Directive Machinery Directive
Approvals	Explosion proof ATEX / IECex
Material certificate	2.2, 3.1
Environment and installation	
Ambient temperature	-10...130 °C, see “Operating limits for ambient and medium temperature” on page 16
Degree of protection	IP65/67
Installation position	As required, preferably with actuator upright

2. Circuit functions

CAUTION

Risk of damage due to bursting pipes and bursting equipment when the flow is above the seat. In the case of liquid mediums, water hammer can occur causing pipes and the device to burst.
Do not use valves with flow above the seat for liquid mediums..

Control function (CF)	Description	
Flow direction below seat for liquids, steam and gases		
	CF: A, pneumatically operated on/off valve 2/2 way Flow direction below seat Normally closed by spring force	
	CF: B, pneumatically operated on/off valve 2/2 way Flow direction below seat Normally open by spring force	
Flow direction above seat for steam and gases		
	CF: A, pneumatically operated on/off valve 2/2 way Flow direction above seat Normally closed by spring force	

3. Approvals

Approvals	Description
	Food contact Materials in contact with the medium conform to EC Regulation 1935/2004 (option) Materials in contact with the medium conform to FDA (option)
	Drinking water Suitable for use with drinking water with medium temperature up to 85 °C according to KTW, W270 (option)
 	Explosion proof As category 2 device suitable for zone 1/21 and zone 2/22 (option) ATEX II 2G Ex h IIC T4 Gb II 2D Ex h IIIC T135 °C Db IECEX Ex h IIC T4 Gb Ex h IIIC T135 °C Db

4. Materials

4.1. Chemical Resistance Chart – Bürkert resistApp

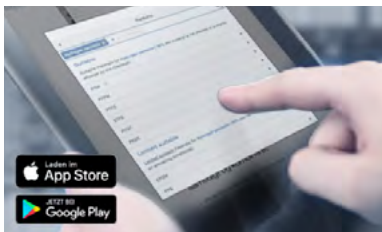

Bürkert resistApp – Chemical Resistance Chart

You want to ensure the reliability and durability of the materials in your individual application case? Verify your combination of media and materials on our website or in our resistApp.

[Start Chemical Resistance Check](#)

4.2. Material specifications

Actuator size 50(D), 70(M), 90(N), 130(P)

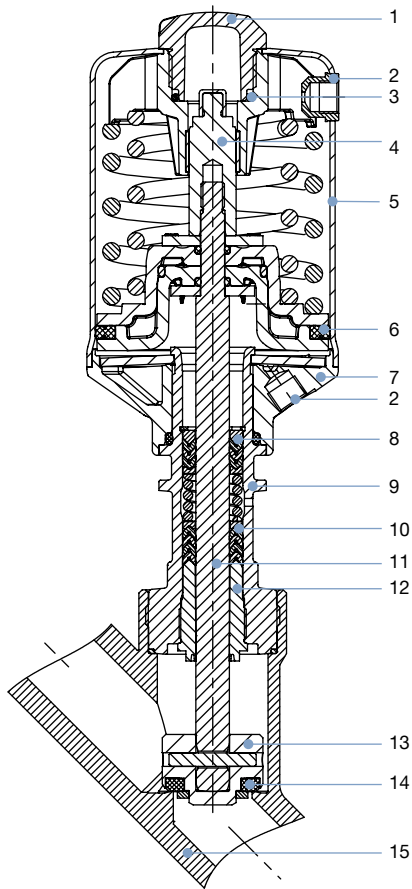

No.	Element	Material
1	Transparent cover	Optical position indicator Polysulfone PSU
2	Pilot air ports	Threaded bushing G 1/8" Stainless steel 1.4404 (316L)
3	Spring support	Stainless steel 1.4308
4	Spindle extension	Stainless steel 1.4104
5	Actuator cover	Stainless steel 1.4404 (316L)
6	Piston seal	FKM
7	Actuator base (interface)	Stainless steel 1.4308
8	Spring	Stainless steel 1.4310
9	Pipe	Stainless steel 1.4401 (316)/1.4404 (316L)
10	Spindle sealing	PTFE V-Rings (filled), with spring compensation
11	Spindle	Stainless steel 1.4401 (316)/1.4404 (316L)
12	Spindle guide	PTFE (filled) for actuator size 50(D)/PEEK for actuator size 70(M), 90(N), 130(P)
13	Swivel plate	Stainless steel 1.4401 (316)/1.4404 (316L)
14	Seat seal	PTFE, PEEK (optional), NBR (optional), FKM (optional)
15	Valve body	Stainless steel CF3M

Actuator size 32(B)

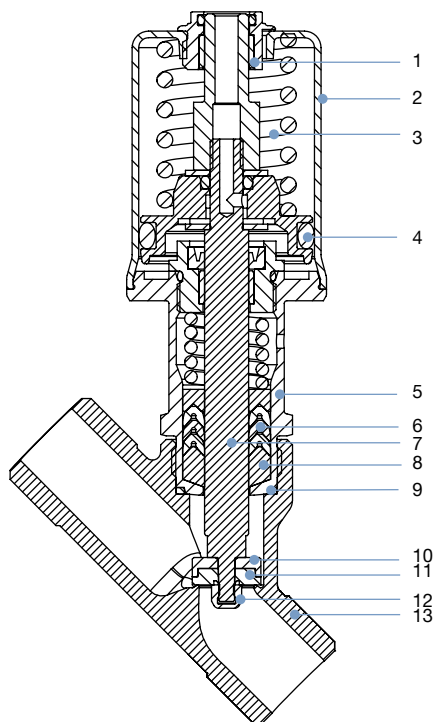

No.	Element	Material
1	Optical position indicator/ Pilot air ports	Stainless steel 1.4104/ Thread M5
2	Actuator cover	Stainless steel 1.4404
3	Spring	1.4310
4	Piston seal	FPM
5	Pipe	Stainless steel 1.4404
6	Spindle seal	PTFE V-Rings (filled) with spring compen- sation
7	Spindle	Stainless steel 1.4404
8	Wiper	PTFE (filled)
9	Body seal	Graphite
10	Seal holder	Stainless steel 1.4404
11	Seat seal	PTFE
12	Dome nut	Stainless steel 1.4404
13	Body	Stainless steel CF3M

DTS 1000290884 EN Version: F Status: RL (released | freigegeben | valide) printed: 28.01.2021

5. Dimensions

5.1. Angle seat valve Type 2060

Note:

Dimensions in mm

Actuator size 50(D)...130(P)

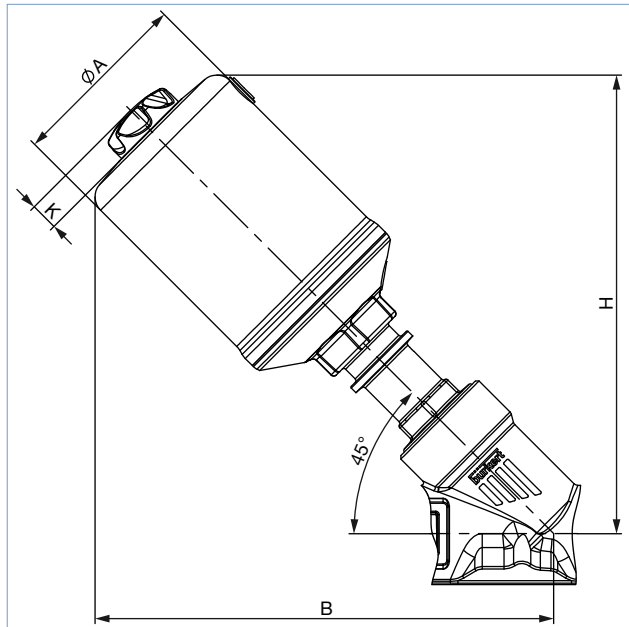

Actuator size 32(B)

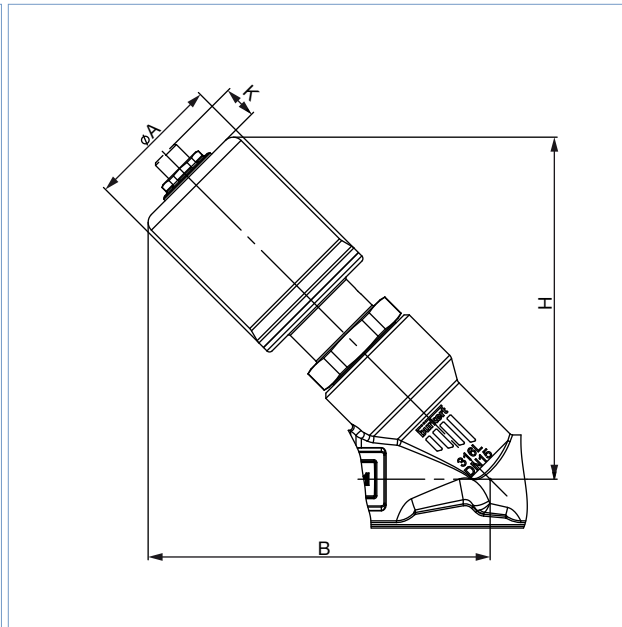

Nominal diameter (pipe)	Actuator size Ø	Ø A	B/H ^{1.)}	K ^{1.)}	P	
DN	NPS					
10	3/8	32 (B)	36.4	87	9.1	M5
		50 (D)	55	154	11	G 1/8
		70 (M)	75	174	11	G 1/8
15	1/2	32 (B)	36.4	98	9.1	M5
		50 (D)	55	154	11	G 1/8
		70 (M)	75	174	11	G 1/8
20	3/4	50 (D)	55	157	11	G 1/8
		70 (M)	75	180	11	G 1/8
25	1	50 (D)	55	169	11	G 1/8
		70 (M)	75	184	11	G 1/8
		90 (N)	96	233	14	G 1/8
32	1 1/4	70 (M)	75	193	11	G 1/8
		90 (N)	96	238	14	G 1/8
		130 (P)	137	283	14	G 1/8
40	1 1/2	70 (M)	75	196	11	G 1/8
		90 (N)	96	242	14	G 1/8
		130 (P)	137	286	14	G 1/8
50	2	70 (M)	75	214	11	G 1/8
		90 (N)	96	257	14	G 1/8
		130 (P)	137	301	14	G 1/8
65	2 1/2	90 (N)	96	269	11	G 1/8
		130 (P)	137	314	14	G 1/8
80	3	130 (P)	137	334	14	G 1/8

1.) Dimensions for B, H and K are maximum dimensions and can be up to 6 mm smaller depending on the nominal diameter and port connection.

5.2. Valve system On/Off ELEMENT Type 8801-YV

Note:
Dimensions in mm

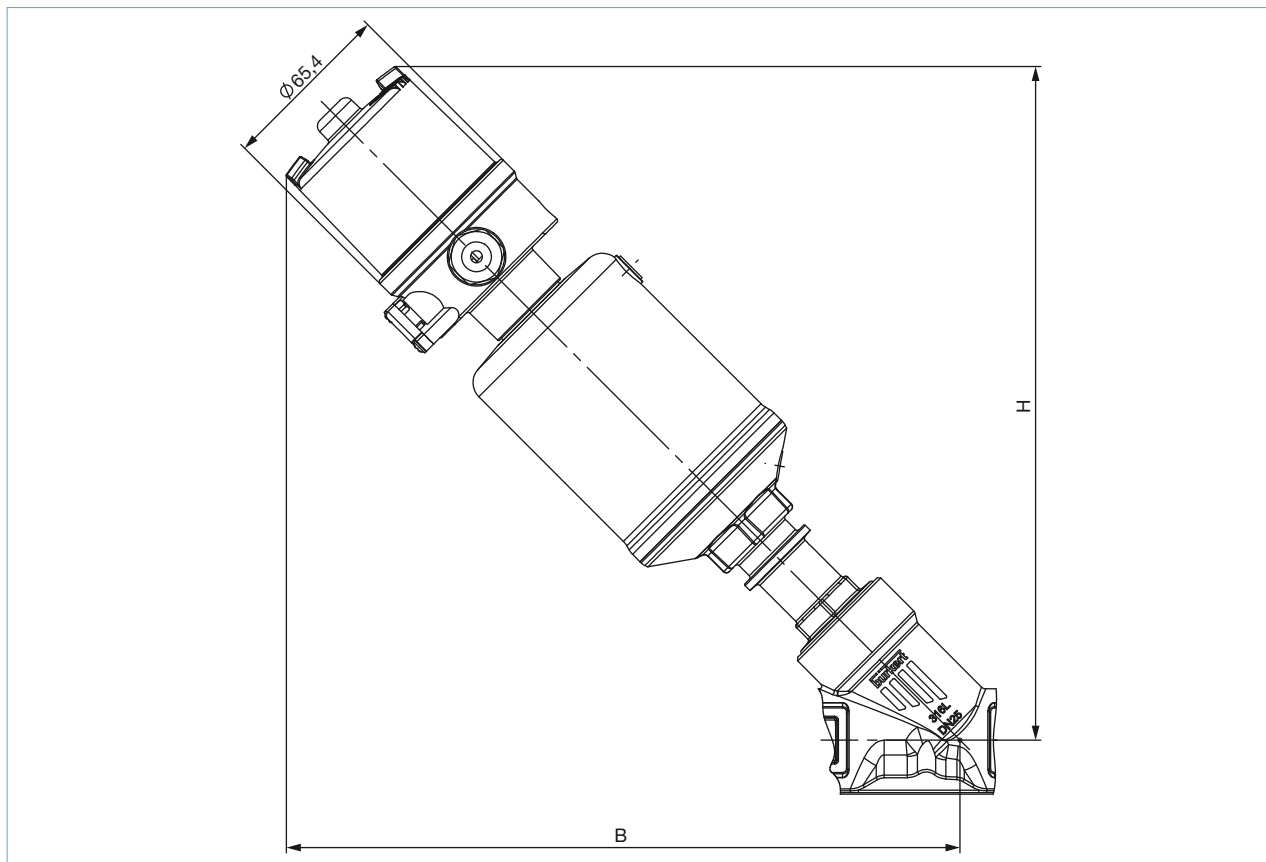

Nominal diameter		Actuator size \varnothing	B/H ^{1.)}
DN	NPS		
10	3/8	50 (D)	230
		70 (M)	244
15	1/2	50 (D)	230
		70 (M)	244
20	3/4	50 (D)	233
		70 (M)	250
25	1	50 (D)	245
		70 (M)	254
		90 (N)	287
32	1 1/4	70 (M)	263
		90 (N)	301
		130 (P)	332
40	1 1/2	70 (M)	266
		90 (N)	305
		130 (P)	335
50	2	70 (M)	284
		90 (N)	320
		130 (P)	350
65	2 1/2	90 (N)	332
		130 (P)	363
80	3	130 (P)	383

1.) Dimensions for B and H are maximum dimensions and can be up to 6 mm smaller depending on the nominal diameter and port connection.

5.3. Body with threaded connection

Note:

Dimensions in mm

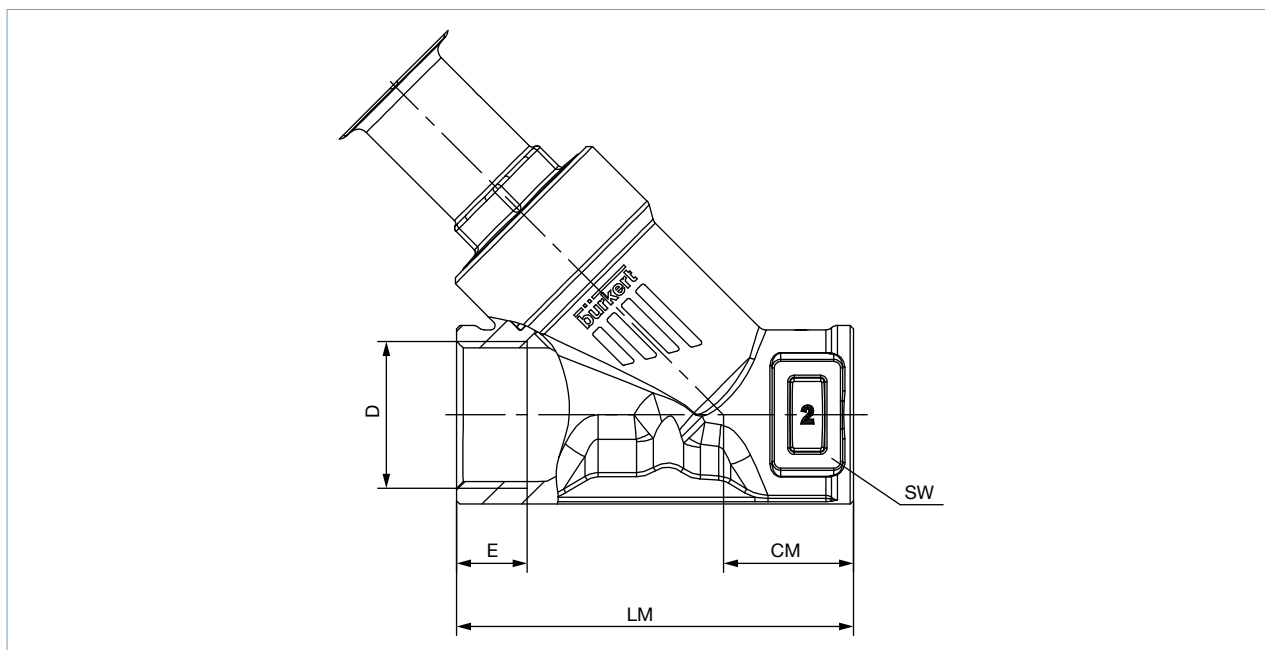

Nominal diameter (pipe)	G, Rc, NPT (EN ISO 228-1, ISO 7/1/DIN EN 10226-2, ASME B 1.20.1)				CM	LM	SW
	D	E					
[DN]	[NPS]	[G]	[NPT]	[Rc]			
15	½	14	13.7	13.2	24	65	27
20	¾	16	14.0	14.5	27	75	34
25	1	18	16.8	16.8	29.5	90	41
32	1¼	16	17.3	19.1	36	110	50
40	1½	18	17.3	19.1	35	120	55
50	2	24	17.6	23.4	45	150	70
65	2½	26	23.7	26.7	57	185	85
80	3	28	–	–	71	220	100

5.4. Body with welded connection

Note:

Dimensions in mm

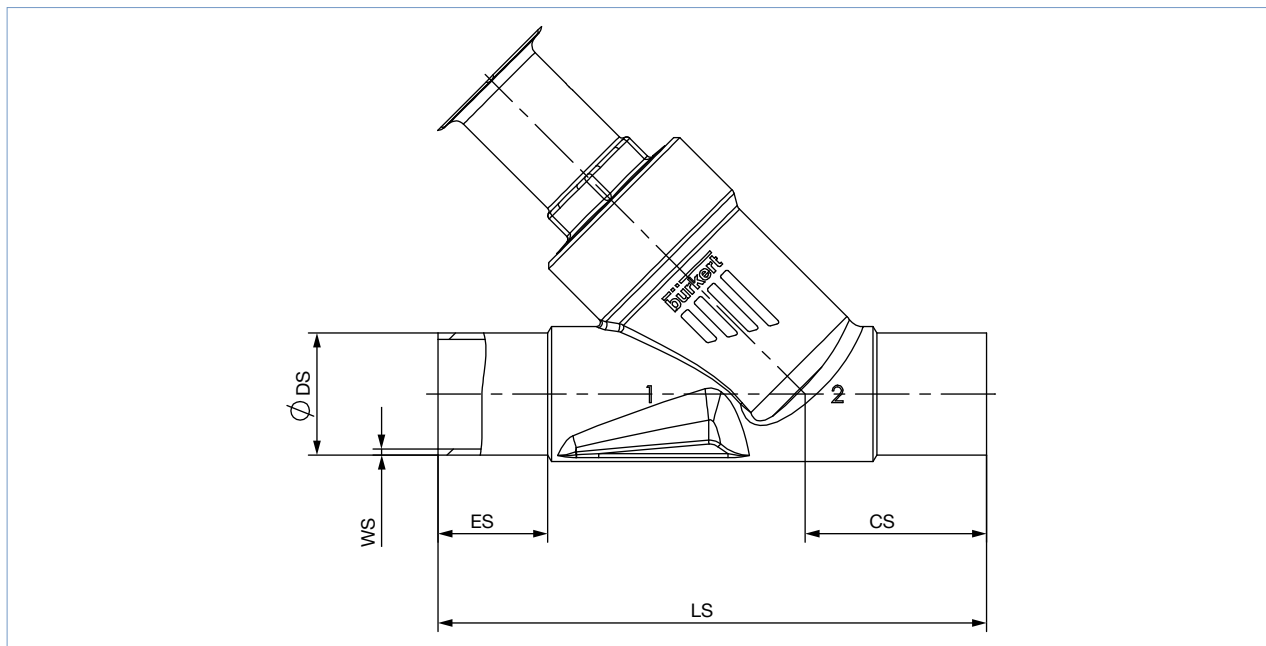

Nominal diameter (pipe)	DIN EN ISO 1127 ISO 4200 DIN 11866 B					DIN 11850 2 DIN 11866 A				
	ES	CS	LS	ØDS	WS	ES	CS	LS	ØDS	WS
15	19	34	100	21.3	1.6	19	34	100	19	1.5
20	20	39	115	26.9	1.6	20	39	115	23	1.5
25	26	43	130	33.7	2.0	26	43	130	29	1.5
32	26	45	145	42.4	2.0	26	45	145	35	1.5
40	26	49	160	48.3	2.0	26	49	160	41	1.5
50	26	50	175	60.3	2.0	26	50	175	53	1.5
65	26	50	210	76.1	2.3	26	50	210	70	2

Nominal diameter (pipe)	ASME BPE DIN 11866 C				
[NPS]	ES	CS	LS	ØDS	WS
½	30	46	135	12.7	1.65
¾	30	52	145	19.05	1.65
1	30	51	152	25.4	1.65
1½	30	60	182	38.1	1.65
2	30	64	210	50.8	1.65
2½	26	56	230	63.5	1.65

DTS 1000290884 EN Version: F Status: RL (released | freigegeben | valide) printed: 28.01.2021

5.5. Body with clamp connection

Note:

Dimensions in mm

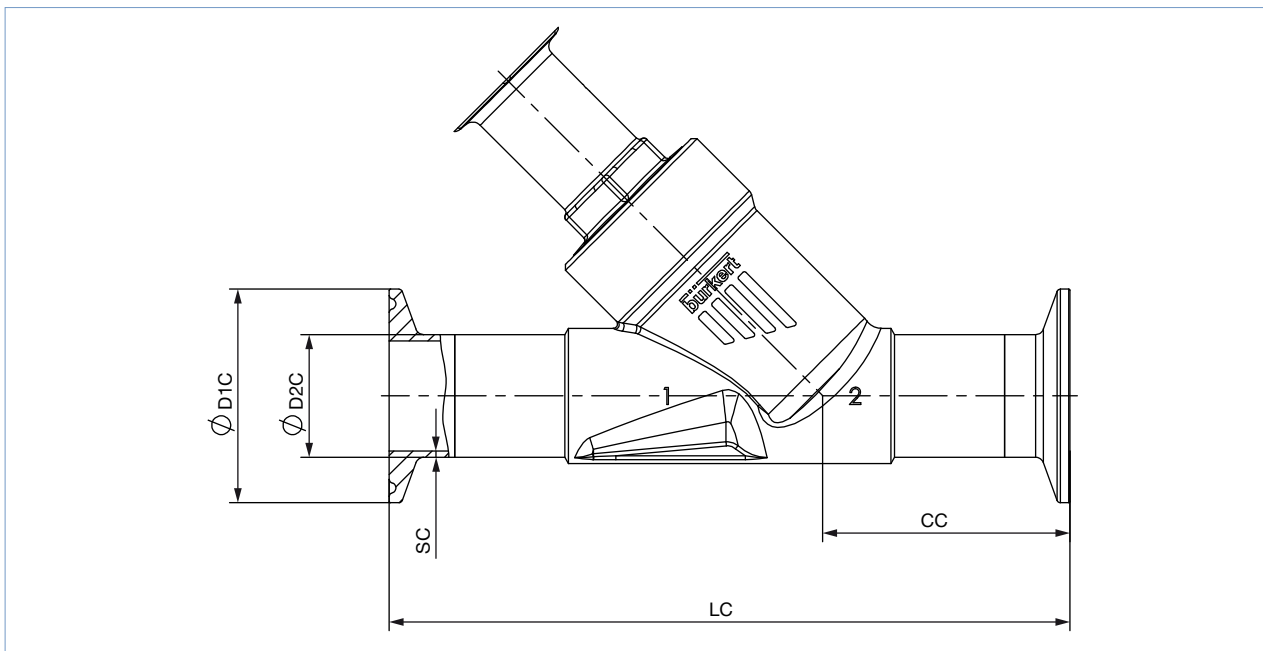

Nominal diameter (pipe)	Clamp: DIN 32676 B					Clamp: DIN 32676 A				
	Pipe: EN ISO 1127 1 ISO 4200 DIN 11866 B					Pipe: DIN 11850 2 DIN 11866 A				
[DN]	LC	CC	ØDC1	ØDC2	SC	LC	CC	ØDC1	ØDC2	SC
15	156	49.0	50.5	21.3	1.6	130	49.5	19	34.0	1.5
20	150	56.5	50.5	26.9	1.6	150	57.0	23	34.0	1.5
25	160	58.0	50.5	33.7	2.0	160	58.5	29	50.5	1.5
32	200	57.5	50.5	42.4	2.0	180	58.0	35	50.5	1.5
40	200	69.0	64.0	48.3	2.0	200	69.5	41	50.5	1.5
50	230	77.5	77.5	60.3	2.6	230	78.0	53	64.0	1.5

Nominal diameter (pipe)	Clamp: ASME BPE				
	Pipe: ASME BPE DIN 11866 C				
[NPS]	LC	CC	ØDC1	ØDC2	SC
½	130	49.0	25.0	12.7	1.65
¾	150	56.5	25.0	19.05	1.65
1	160	58.0	50.5	25.4	1.65
1½	200	69.0	50.5	38.1	1.65
2	230	77.5	64.0	50.8	1.65

DTS 1000290884 EN Version: F Status: RL (released | freigegeben | valide) printed: 28.01.2021

6. Performance specifications

6.1. Fluidic data

Overview of fluidic data for flow below seat (for gases, steam and liquids)

Note:

- K_v value [m^3/h]: Measured with water at +20 °C, 1 bar pressure at valve inlet and free outlet
- Pressure data [bar]: Overpressure to atmospheric pressure

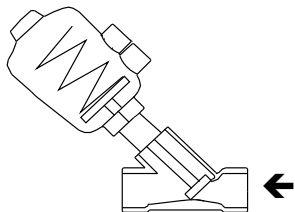

Nominal diameter		Actuator size Ø	K_v value	Pilot pressure min.	Max. operating pressure		
					CF: A	CF: A	CF: B
					Seat seal		
					PTFE	PEEK	PTFE
DN	NPS	[mm]	[m^3/h]	[bar(g)]	[bar(g)]	[bar(g)]	[bar(g)]
10	3/8	32 (B)	2.4	5.5	16	–	16
		50(D)	4.2	4.1	16	–	16
		70(M)	4.8	4.8	25	25	25
15	1/2	32 (B)	4	5.5	11	–	–
		50(D)	4.2	4.1	16	–	16
		70(M)	5	4.8	25	25	25
20	3/4	50(D)	8	4.1	11	8.5	16
		70(M)	11	4.8	25	25	25
25	1	50(D)	14	4.1	5.2	–	16
		70(M)	18	4.8	16	13.5	25
		90 (N)	18	5	25	25	25
32	1 1/4	70(M)	27	4.8	8.5	–	25
		90 (N)	28	5	25	19.5	25
		130(P)	28	5	–	25	–
40	1 1/2	70(M)	38	4.8	6	–	25
		90 (N)	40	5	16	13.5	25
		130(P)	42	5	25	25	25
50	2	90 (N)	55	5	10	–	25
		130(P)	62	5	25 (20 ^{1.)})	23 (20 ^{1.)})	25 (20 ^{1.)})
65	2 1/2	90 (N)	85	5	5	–	11
		130(P)	95	5.6	16	12.5	17 (15 ^{1.)})
80	3	130(P)	140	5.6	10	8	11

1.) According to pressure equipment directive 2014/68/EU for compressible fluids of group 1 (dangerous gases and vapours according to article 4, paragraph (1), c), i), first indent)

Pilot pressure diagram with flow direction below seat (control function B, seat seal PTFE)

Actuator size: Ø32(B)

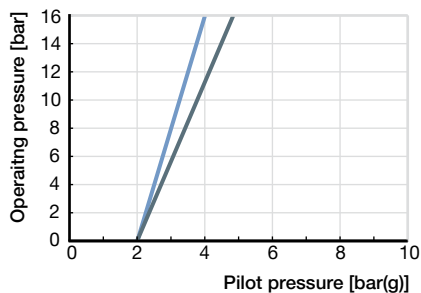

Orifice:
 DN10 — (blue)
 DN15 — (grey)

Actuator size: Ø50(D)

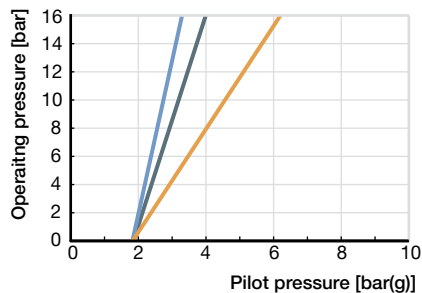

Orifice:
 DN15 — (blue)
 DN20 — (grey)
 DN25 — (orange)

Actuator size: Ø70(M)

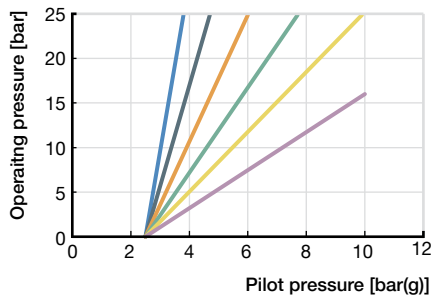

Orifice:
 DN15 — (blue) DN32 — (green)
 DN20 — (grey) DN40 — (yellow)
 DN25 — (orange) DN50 — (purple)

Actuator size: Ø90(N)

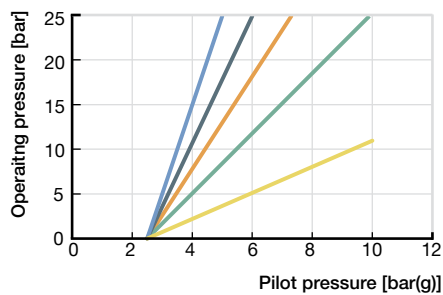

Orifice:
 DN25 — (blue) DN50 — (green)
 DN32 — (grey) DN65 — (yellow)
 DN40 — (orange)

Actuator size: Ø130(P)

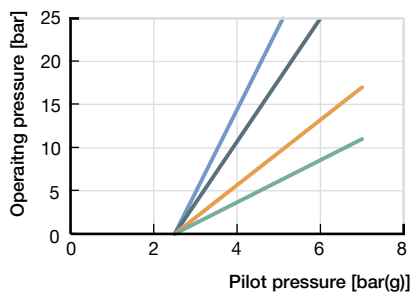

Orifice:
 DN40 — (blue) DN65 — (orange)
 DN50 — (grey) DN80 — (green)

DTS 1000290884 EN Version: F Status: RL (released | freigegeben | valide) printed: 28.01.2021

Overview of fluidic data with flow above seat (for gases and steam)

Note:

- K_v value [m^3/h]: Measured with water at +20 °C, 1 bar pressure at valve inlet and free outlet
- Pressure data [bar]: Overpressure to atmospheric pressure

CAUTION

Risk of damage due to bursting pipes and bursting equipment when the flow is above the seat. In the case of liquid mediums, water hammer can occur causing pipes and the device to burst.

Do not use valves with flow above the seat for liquid mediums..

Nominal diameter/ Orifice		Actuator size [mm]	K_v value water [m^3/h]	Max. operating pressure bis + 185 °C
[mm]	[inch]			CF: A [bar]
15	1/2"	50(D)	4.2	16
20	3/4"	50(D)	8	16
25	1"	50(D)	14	16
32	1 1/4"	70(M)	28	16
40	1 1/2"	70(M)	38	16
50	2"	70(M)	50	12
		90(N)	55	15

Pilot pressure diagram with flow direction above seat (control function A)

Actuator size: Ø50(D)

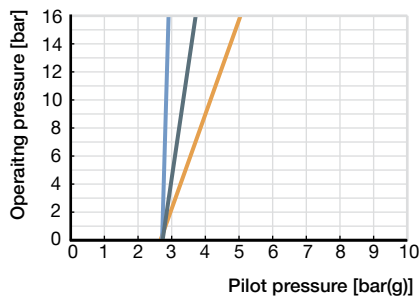

Orifice:
 DN15 — (blue line)
 DN20 — (grey line)
 DN25 — (orange line)

Actuator size: Ø70(M)

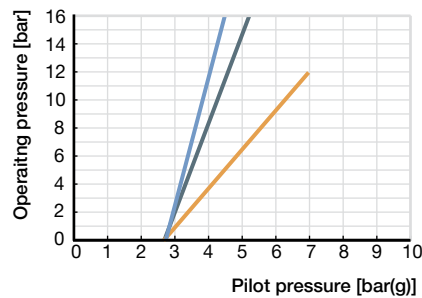

Orifice:
 DN32 — (blue line)
 DN40 — (grey line)
 DN50 — (orange line)

Actuator size: Ø90(N)

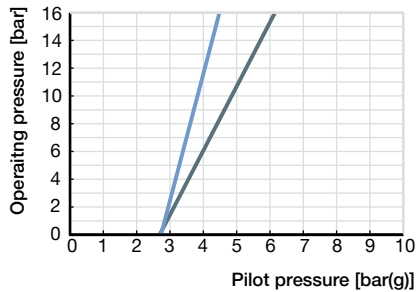

Orifice:
 DN40 — (blue line)
 DN50 — (grey line)

DTS 1000290884 EN Version: F Status: RL (released | freigegeben | validé) printed: 28.01.2021

6.2. Operating limits

Operating limits for medium temperature and operating pressure

The operating range of Bürkert process valves is in addition to the maximum operating pressures limited by the nominal pressure according to the relevant standard.

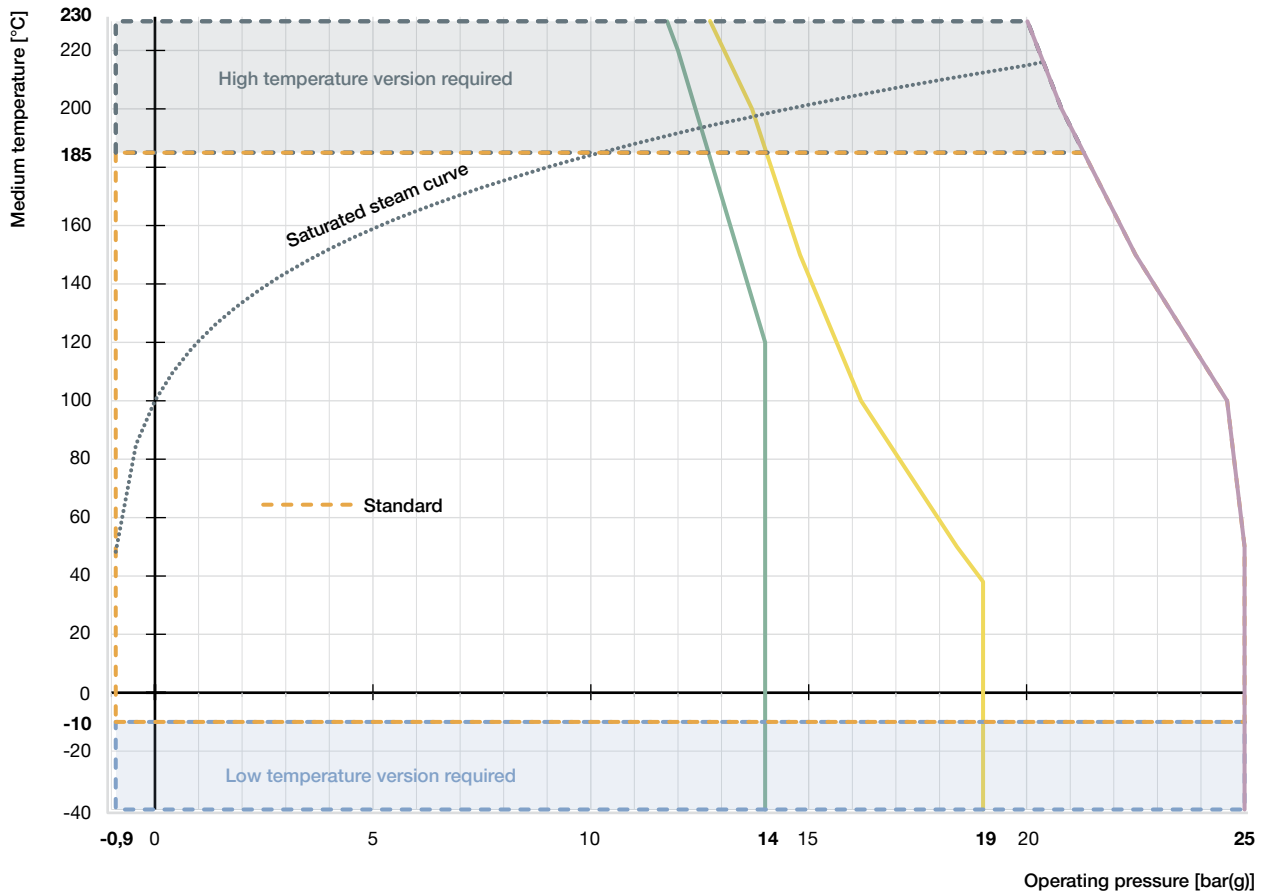

- Operating limits for PN25 acc. to DIN EN 12516-1
- Operating limits for flange 10K acc. to JIS B 2220
- Operating limits for Class 150 acc. to ASME B16.34
- ⋯ Saturated steam curve for water

Operating limits for ambient and medium temperature

Stainless steel actuator

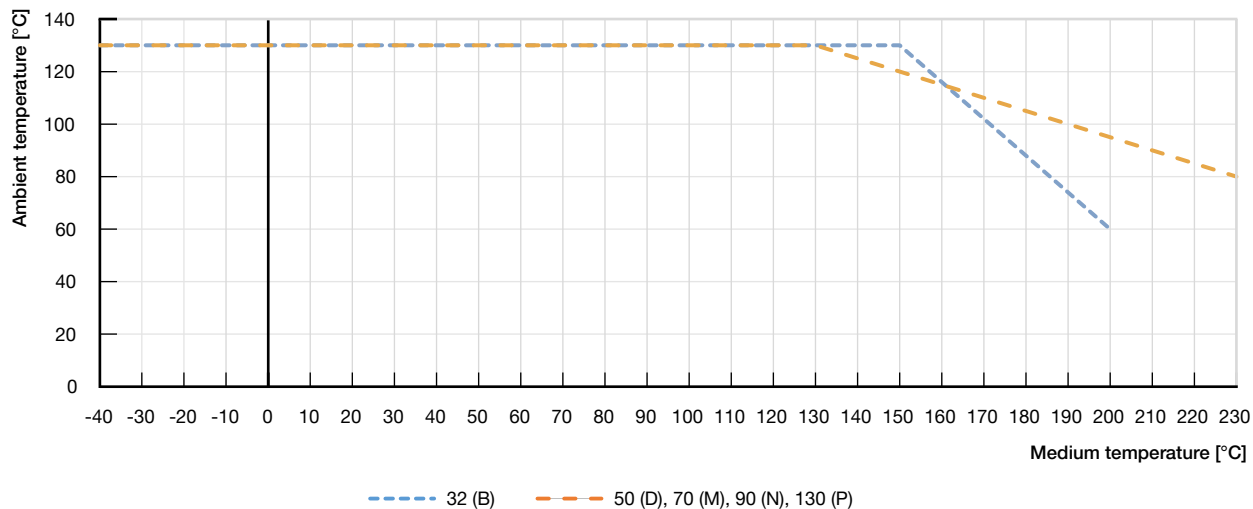

Operating limits for optional versions

High temperature version

By adapting the spindle sealing and seat seal in PEEK, this version is suitable for applications with steam, neutral gases and other heat transfer mediums up to 230 °C.

Hot water version

For applications with hot water up to 200 °C a special configuration of the spindle seal increases the lifetime significantly. It is recommended for water temperatures starting at 85 °C.

Vacuum version

Without leakage bore, this design is suitable down to -0.9 bar(g).

Low temperature version

Suitable for minimum medium temperatures down to -40 °C

7. Product accessories

Electric position feedback sensor	
Type 8697 ▶ Actuator size 50(D) ... 130(P)	Description The position feedback Type 8697 is designed for integrated mounting on CLASSIC series 20XX process valves suiting the requirements of hygienic process environment Mechanical or inductive limit switches register the position of the valve Features <ul style="list-style-type: none"> • Compact design • LED position indicator • Mechanical or inductive limit switches for end position registering • Easy to clean chemically resistant housing featuring IP65/IP67, 4X Rating • Optional intrinsically safe version acc. to ATEX Customer benefits <ul style="list-style-type: none"> • Easy and quick installation • High level of signal reliability thanks to self adjusting limit switches • Minimised space requirement in the plant piping for more flexibility in plant design
	
Adaptation for proximity switch	
Type 2xxx ▶	Description Various options for the use of inductive proximity switches are available for the actuators of the CLASSIC series: <ul style="list-style-type: none"> • Nipple • Support bracket, 1-fold • Support bracket, 2-fold
Stroke limiter	
Type 2xxx ▶	Description Stroke limitations can be used to limit the minimum (min.) and maximum (max.) flow rate of the valves. Different versions are available: <ul style="list-style-type: none"> • Max. Stroke Limitation • Max. and min. stroke limitation with optical position indicator

8. Networking and combination with other Bürkert products

The angled seat valve Type 2060 can be combined with the feedback positioner Type 8697 to form the valve system On/Off Type 8801-YV.

Note:

- For the configuration of further valve systems please use the product enquiry form at the end of this document.
- You order two components and receive a completely assembled and tested valve.

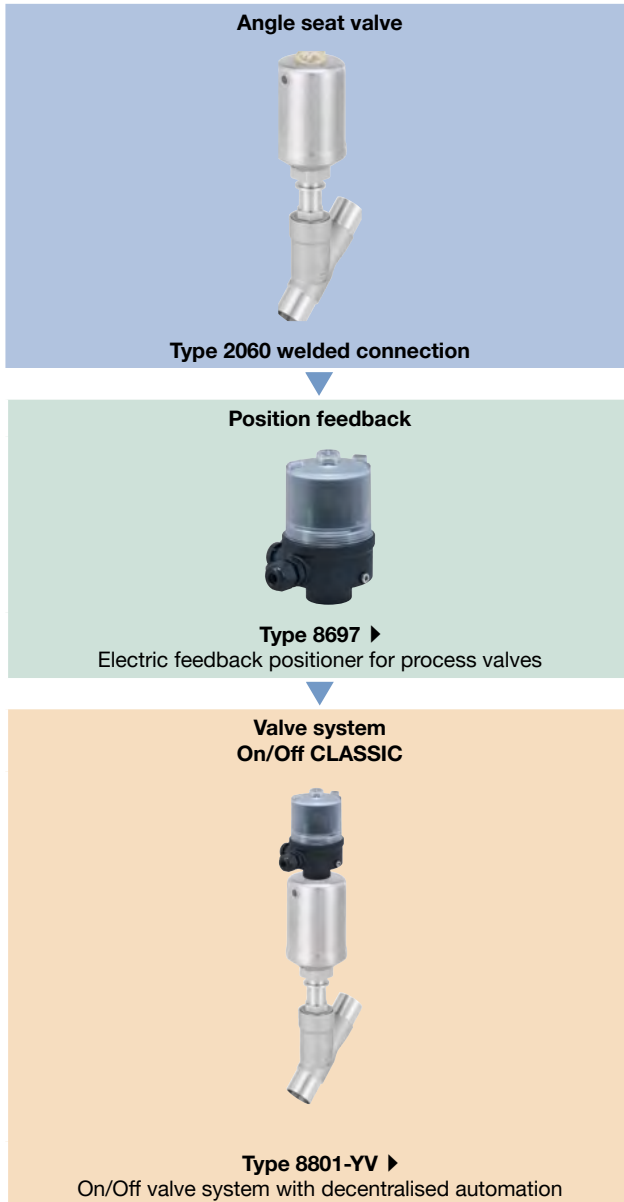

DTS 1000290884 EN Version: F Status: RL (released | freigegeben | validé) printed: 28.01.2021

9. Ordering information

9.1. Bürkert eShop – Easy ordering and quick delivery



Bürkert eShop – Easy ordering and fast delivery

You want to find your desired Bürkert product or spare part quickly and order directly? Our online shop is available for you 24/7. Sign up and enjoy all the benefits.

[Order online now](#)

9.2. Bürkert product filter



Bürkert product filter – Get quickly to the right product

You want to select products comfortably based on your technical requirements? Use the Bürkert product filter and find suitable articles for your application quickly and easily.

[Try out our product filter](#)

9.3. Ordering chart welded connection

Valve with flow direction below seat





Control function	Nominal diameter/ Orifice		Port connection pipe-Ø x wall thick- ness	Actuator size	Pilot pres- sure	Operating pressure bis + 185 °C	Article no.
	[mm]	[inch]					
EN ISO 1127/ISO 4200/DIN 11866 series B							
CF: A, pneumatically operated on/off valve ¹⁾	10	¾	17.2 x 1.6	32(B)	5.5...10	16	387585
	15	½	21.3 x 1.6	32(B)	5.5...10	11	387629
				50(D)	4.1...10.5	16	285215
	20	¾	26.9 x 1.6	50(D)	4.1...10.5	11	285217
				70(M)	4.8...10.5	25	285218
	25	1	33.7 x 2.0	50(D)	4.1...10.5	5.2	285219
				70(M)	4.8...10.5	16	285220
	32	1¼	42.4 x 2.0	70(M)	4.8...10.5	8.5	285221
				90(N)	5.0...10.5	25	285222
	40	1½	48.3 x 2.0	70(M)	4.8...10.5	6	285223
				90(N)	5.0...10.5	16	285224
	50	2	60.3 x 2.0	90(N)	5.0...10.5	10	285515
130(P)				5.0...7.5	25	285705	
65	2½	76.1 x 2.3	90(N)	5.0...10.5	5	285227	
			130(P)	5.6...7.5	12	285228	

Control function	Nominal diameter/ Orifice		Port connection pipe-Ø x wall thick- ness	Actuator size	Pilot pres- sure	Operating pressure bis + 185 °C	Article no.
	[mm]	[inch]					
CF: B, pneumatically operated on/off valve ^{1.)}	10	3/8	17.2 x 1.6	32 (B)	5.5...10	16	387647
	15	1/2	21.3 x 1.6	32 (B)	5.5...10	16	387651
				50(D)	See diagram for valves with Flow direction below seat ^{2.)}	16	285500
	70(M)	25	287565				
	20	3/4	26.9 x 1.6	50(D)		16	285501
				70(M)		25	287566
	25	1	33.7 x 2.0	70(M)	25	285503	
	32	1 1/4	42.4 x 2.0	70(M)	25	285504	
	40	1 1/2	48.3 x 2.0	70(M)	25	285505	
	50	2	60.3 x 2.0	70(M)	16	287567	
65	2 1/2	76.1 x 2.3	90(N)	11	285511		
DIN 11850 series 2/DIN 11866 series A/DIN EN 10357 series A							
CF: A, pneumatically operated on/off valve ^{1.)}	10	3/8	13.0 x 1.5	32 (B)	5.5...10	16	387605
	15	1/2	19.0 x 1.5	32 (B)	5.5...10	11	387596
				50(D)	4.1...10.5	16	285201
	20	3/4	23.0 x 1.5	50(D)	4.1...10.5	11	285203
				70(M)	4.8...10.5	25	285204
	25	1	29.0 x 1.5	50(D)	4.1...10.5	5.2	285205
				70(M)	4.8...10.5	16	285206
	32	1 1/4	35.0 x 1.5	70(M)	4.8...10.5	8.5	285207
				90(N)	5.0...10.5	25	285208
	40	1 1/2	41.0 x 1.5	70(M)	4.8...10.5	6	285209
				90(N)	5.0...10.5	16	285210
	50	2	53.0 x 1.5	90(N)	5.0...10.5	10	285211
				130(P)	5.0...7.5	25	285212
	65	2 1/2	70.0 x 2.0	90(N)	5.0...10.5	5	285213
130(P)				5.6...7.5	12	285214	
CF: B, pneumatically operated on/off valve ^{1.)}	10	3/8	13.0 x 1.5	32 (B)	5.5...10	16	387633
	15	1/2	19.0 x 1.5	32 (B)	5.5...10	16	387623
				50(D)	See diagram for valves with Flow direction below seat ^{2.)}	16	287555
	70(M)	25	287556				
	20	3/4	23.0 x 1.5	50(D)		16	287557
				70(M)		25	287558
	25	1	29.0 x 1.5	70(M)	25	287559	
	32	1 1/4	35.0 x 1.5	70(M)	25	287560	
	40	1 1/2	41.0 x 1.5	70(M)	25	287561	
	50	2	53.0 x 1.5	90(N)	16	287562	
65	2 1/2	70.0 x 2.0	90(N)	11	287563		

Control function	Nominal diameter/ Orifice		Port connection pipe-Ø x wall thick- ness	Actuator size	Pilot pres- sure	Operating pressure bis + 185 °C	Article no.
	[mm]	[inch]					
ASME BPE/DIN 11866 series C							
CF: A, pneumatically operated on/off valve ^{1.)}	10	3/8	12.7 x 1.65	32 (B)	5.5...10	16	387603
	15	1/2	12.7 x 1.65	32 (B)	5.5...10	11	387637
				50(D)	4.1...10.5	16	285189
	20	3/4	19.05 x 1.65	50(D)	4.1...10.5	11	285191
				70(M)	4.8...10.5	25	285192
	25	1	25.4 x 1.65	50(D)	4.1...10.5	5.2	285193
				70(M)	4.8...10.5	16	285194
	40	1 1/2	38.1 x 1.65	70(M)	4.8...10.5	6	285195
				90(N)	5.0...10.5	25	285196
	50	2	50.8 x 1.65	90(N)	5.0...10.5	10	285197
				130(P)	5.0...7.5	25	285198
	65	2 1/2	63.5 x 1.65	90(N)	5.0...10.5	5	285199
				130(P)	5.6...7.5	12	285200
	CF: B, pneumatically operated on/off valve ^{1.)}	10	3/8	12.7 x 1.65	32 (B)	5.5...10	16
15		1/2	12.7 x 1.65	32 (B)	5.5...10	16	On request
				50(D)	See diagram for valves with Flow direction below seat ^{2.)}	16	285499
20		3/4	19.05 x 1.65	70(M)		25	287548
				50(D)	16	287549	
25		1	25.4 x 1.65	70(M)	25	287550	
				70(M)	25	287551	
40		1 1/2	38.1 x 1.65	70(M)	25	287552	
50		2	50.8 x 1.65	70(M)	16	285509	
65		2 1/2	63.5 x 1.65	90(N)	11	287553	

1.) Further information in chapter "2. Circuit functions" on page 4

2.) See diagram in chapter "Pilot pressure diagram with flow direction below seat (control function B, seat seal PTFE)" on page 13

Further versions on request	
 Approval Drinking water, explosion protection	 Pressure Other versions for operating pressures up to 25 bar(g) Vacuum version down to -0.9 bar(g)
 Temperature High temperature version up to 230 °C Hot water version up to 200 °C Low temperature version down to -40 °C	 Process connection Threaded/Clamp

Valves with flow direction above seat

Control function	Nominal diameter/ Orifice		Port connection pipe-Ø x wall thick- ness	Actuator size	Pilot pres- sure	Operating pressure bis+ 185 °C	Article no.
	[mm]	[inch]					
EN ISO 1127/ISO 4200/DIN 11866 series B							
CF: A, pneumatically operated on/off valve ^{1.)}	15	½	21.3 × 1.6	50(D)	See diagram for valves with Flow direction above seat ^{2.)}	16	287541
	20	¾	26.9 × 1.6	50(D)		16	287542
	25	1	33.7 × 2.0	50(D)		16	287543
	32	1¼	42.4 × 2.0	70(M)		16	287544
	40	1½	48.3 × 2.0	70(M)		16	287545
	50	2	60.3 × 2.0	70(M)		16	287546
				90(N)		16	287547
DIN 11850 series 2/DIN 11866 series A/DIN EN 10357 series A							
CF: A, pneumatically operated on/off valve ^{1.)}	15	½	19.0 × 1.5	50(D)	See diagram for valves with Flow direction above seat ^{2.)}	16	287534
	20	¾	23.0 × 1.5	50(D)		16	287535
	25	1	29.0 × 1.5	50(D)		16	287536
	32	1¼	35.0 × 1.5	70(M)		16	287537
	40	1½	41.0 × 1.5	70(M)		16	287538
	50	2	53.0 × 1.5	70(M)		12	287539
				90(N)		16	287540
ASME BPE/DIN 11866 series C							
CF: A, pneumatically operated on/off valve ^{1.)}	15	½	12.7 × 1.65	50(D)	See diagram for valves with Flow direction above seat ^{2.)}	16	287528
	20	¾	19.05 × 1.65	50(D)		16	287529
	25	1	25.4 × 1.65	50(D)		16	287530
	40	1½	38.1 × 1.65	70(M)		16	287531
	50	2	50.8 × 1.65	70(M)		12	287532
				90(N)		16	287533

1.) Further information in chapter "2. Circuit functions" on page 4

2.) See diagram in chapter "Pilot pressure diagram with flow direction above seat (control function A)" on page 14

9.4. Ordering chart accessories

Note:

- For further accessories see separate data sheet, Accessories **Type 2XXX** ▶, for the complete range of accessories.
- Accessories must be ordered separately

Accessories	For actuator size	Article no.
Stainless steel silencer set (St. st. silencer incl. PTFE sealing ring)	Universal	696931
Max. stroke limitation	Ø50(D), Ø70(M)	699550
	Ø90(N), Ø130(P)	699994
Min./Max. stroke limitation	Ø50(D), Ø70(M)	699986
	Ø90(N), Ø130(P)	699998
Proximity switch (single)	Ø50(D), Ø70(M)	699989
	Ø90(N), Ø130(P)	699991
Proximity switch (double)	Ø50(D), Ø70(M)	699990
	Ø90(N), Ø130(P)	699992
Adaption set Type 8697	Ø50(D), Ø70(M)	699551
	Ø90(N), Ø130(P)	580000
Type 8697	Universal	Depending on version
Angled screw-in connector 45° - M5...Ø 4 mm	Ø32(B)	903383
Angled screw-in connector 45° - M5...Ø 6 mm	Ø32(B)	771077

Bürkert – Close to You

For up-to-date addresses
please visit us at
www.burkert.com

DTS 1000290884 EN Version: F Status: RL (released | freigegeben | validé) printed: 28.01.2021



Product Enquiry Form - Pneumatic Shut-off Valves

Thank you for your interest in our products! In order to provide you with optimum advice, please fill out the following form and send it to your **Bürkert representative** or e-mail address: info@burkert.com. All information submitted will of course be kept strictly confidential.

Please fill in the required fields! *

*Note: The interactive functions of this PDF may be restricted depending on the PDF reader used.

Personal Information				
Company			Contact person	
Customer no.			Department	
Street			Postcode / Town	
Telephone no.			Email	

Delivery	
Quantity	Required delivery date

Operating data				
Function <small>(Function of the control valve in the process / process description)</small>				
Pipeline	DN			PN
Operating medium				
Type of medium	Fluid	Steam	Gas	
Operating pressure			Unit	
Medium temperature			°C /	°F
Ambient temperature			°C /	°F

Valve body				
Construction	Angle seat valve		Globe valve	
Actuator material	Stainless steel/PPS		Stainless steel	PPS PA
Housing material	Stainless steel		Gunmetal	
Seat seal	PTFE EPDM		NBR Other	PEEK FKM
DN / Nominal pressure	DN		PN	
Flow coefficient	K_v	m^3/h	C_v	GPM(US)
Connection	Flange	DIN EN 1092-1		ANSI B16.5 JIS 10K
	Thread	G		NPT RC
	Weld	DIN EN ISO 1127 / ISO 4200		DIN 11850 2 / DIN 11866 A ASME BPE
	Clamp	ASME BPE		DIN 32676 A (tube ISO 4200) DIN 32676 B (tube DIN 11850)
	Other			

Valve data	
Circuit Function	A: Normally closed B: Normally open I: Double acting
Control pressure	Min. Max.

DTS 1000290884 EN Version: F Status: RL (released | freigegeben | validé) printed: 28.01.2021

Approvals / Conformities

For use with food (conform to EG regulation no. 1935/2004)
For use with food (conform to FDA)
Explosion protection in accordance with ATEX II 2GD mech. / IECEx
European Gas Appliances Directive (EU) 2016/426, DVGW DIN EN 161 and DIN EN 16678
For potable water according to KTW/W270
Certificate for the fulfilment of the order EN-ISO 10204 2.1 (Article no. 440788)
Test report EN-ISO 10204 2.2 (Article no. 803722)
Conformity certification for raw material EN-ISO 10204 3.1 (included)

Additional Requirements / Comment

Automation unit features

For actuator size ø40 to 225 mm

Electrical position feedback Type 8697 ▶				
	<ul style="list-style-type: none"> • Optical position indicator • Mechanical or inductive limit switches for end position registering • Optional intrinsically safe version acc. to ATEX / IECEx 			
	Electrical connection		Number of end position feedback switches	
Cable gland		M12 connector ^{1.)}	2x Micro – or inductive	
Approvals				
ATEX cat. 3GD, IECEx		ATEX cat. 2DG, IECEx	Without	
Position feedback switch				
Micro switch 24 V DC		Micro switch 50...225 V DC/AC	Inductive switch 3-wire PNP	
Inductive switch 2-wire NAMUR		Inductive switch 2-wire 24 V DC	Without	

1.) Applicable only with inductive switch 3-wire PNP

DTS 1000290884 EN Version: F Status: RL (released | freigegeben | validé) printed: 28.01.2021