

PROVU™ PD6060 Dual Analog Input Process Meter

Instruction Manual



PROVU
SERIES



MeterView Pro

USB Install

- 1/8 DIN Digital Panel Meter with NEMA 4X, IP65 Front
- Dual 0-20 mA, 4-20 mA, 0-5 V, 1-5 V, and ± 10 V Inputs with Math Functions
- Addition, Difference, Average, Multiplication, Div, Min, Max, Ratio, & More
- Dual-Line 6-Digit Display, 0.6" (15 mm) & 0.46" (12 mm)
- Isolated 24 VDC @ 200 mA Transmitter Power Supply
- Easy Field Scaling in Engineering Units without Applying an Input
- 2 or 4 Relays with Interlocking Capability + Isolated 4-20 mA Output Options
- Free PC-Based, On-Board, MeterView Pro USB Programming Software
- No Assembly Required
- Optional SunBright Display Models for Outdoor Applications
- Operating Temperature Range: -40 to 65°C (-40 to 149°F)
- UL & C-UL Listed. E160849; 508 Industrial Control Equipment
- Input Power Options: 85-265 VAC / 90-265 VDC or 12-24 VDC / 12-24 VAC
- Display Input in Two Different Scales Simultaneously - Great for Level Applications
- Multi-Pump Alternation Control
- Round Horizontal Tank Function; Just Enter Diameter & Length
- 32-Point Linearization, Square Root Extraction and Programmable Exponent Function
- Programmable Display, Function Keys & Digital Input
- External 4-Relay, Dual 4-20 mA Outputs & Digital I/O Expansion Modules
- Password Protection
- RS-232 & RS-485 Serial Communication Options with Modbus RTU
- Wide Assortment of NEMA 4X Enclosures for up to Ten Meters
- Light / Horn & Reset Button Accessory
- Control Station Accessory for Remote Operation of PROVU
- 3-Year Warranty

PRECISION DIGITAL CORPORATION

233 South Street • Hopkinton MA 01748 USA
Tel (800) 343-1001 • Fax (508) 655-8990

www.predig.com

**PRECISION
DIGITAL**

Disclaimer

The information contained in this document is subject to change without notice. Precision Digital makes no representations or warranties with respect to the contents hereof and specifically disclaims any implied warranties of merchantability or fitness for a particular purpose. See Warranty Information and Terms & Conditions on www.predig.com for complete details.

CAUTION

- Read complete instructions prior to installation and operation of the meter.

WARNINGS

- Risk of electric shock or personal injury.
- This product is not recommended for life support applications or applications where malfunctioning could result in personal injury or property loss. Anyone using this product for such applications does so at his/her own risk. Precision Digital Corporation shall not be held liable for damages resulting from such improper use.

WARNING

Cancer and Reproductive Harm - www.P65Warnings.ca.gov

Limited Warranty

Precision Digital Corporation warrants this product against defects in material or workmanship for the specified period under "Specifications" from the date of shipment from the factory. Precision Digital's liability under this limited warranty shall not exceed the purchase value, repair, or replacement of the defective unit. See Warranty Information and Terms & Conditions on www.predig.com for complete details.

Registered Trademarks

All trademarks mentioned in this document are the property of their respective owners.

© 2020 Precision Digital Corporation.
All rights reserved.

FREE MeterView Pro Programming Software



*The meter can be powered from the Micro USB connection. When using the Micro USB connection, **DO NOT** apply AC or DC power to the meter.*

The easiest and quickest way to program your PROVu meter is to use the FREE MeterView Pro programming software. This software is loaded into the meter and connects and installs directly to your PC with a USB cable. We recommend that the first thing you do after taking the meter out of the box is connect the PROVu to your PC with the provided USB cable – do not use a different cable. **DO NOT** apply AC or DC power to the meter while your PC is connected to the meter as it will disrupt the USB connection. You don't even have to apply an input signal.

MeterView Pro programming software is intuitive, and most customers can get their meter programmed as they like without even looking in the manual.

Watch MeterView Pro Software Video at www.predig.com/meterviewpro

In addition to programming, the software may be used for:

- Monitoring
- Datalogging using your PC
- Generating and saving programming files for later use

Once your meter is programmed the way you want it, you can wire it up for your application per the instructions in this manual and install it. If you find that you need to make adjustments to the programming after the meter is installed, you can use the front panel buttons and the instructions in this manual to do so.

Table of Contents

- Introduction6
- Ordering Information6
- Specifications.....7
 - General7
 - Dual Process Input8
 - Relays9
 - Isolated 4-20 mA Transmitter Output9
 - USB Connection10
 - On-Board Digital Input (F4).....10
 - Modbus® RTU Serial Communications.....10
 - MeterView Pro.....10
- Compliance Information.....11
 - Safety11
 - Electromagnetic Compatibility11
- Safety Information11
- Installation11
 - Unpacking11
 - Panel Mounting Instructions12
 - Mounting Dimensions.....12
 - Installation Overview.....13
 - MeterView Pro Software.....13
 - MeterView Pro Installation.....13
 - Transmitter Supply Voltage Selection (P+, P-)14
 - Connections.....14
 - Connectors Labeling14
 - Power Connections15
 - Signal Connections15
 - Modbus RTU Serial Communications15
 - Relay Connections15
 - Switching Inductive Loads.....16
 - F4 Digital Input Connections16
 - 4-20 mA Output Connections.....16
 - Analog Output Power Supply16
 - External Relay, Analog Output, & Digital I/O Connections.....17
 - Interlock Relay Feature17
- Setup and Programming18
 - Overview.....18
 - Front Panel Buttons and Status LED Indicators18
 - Display Functions & Messages.....19
 - Main Menu21
 - Setting Numeric Values21
 - Setting Up the Meter (SEtUP)21
 - Setting the Input Signal (InPUt).....22
 - Setting the Display Units or Custom Tags (uNITS)22
 - Setting the Decimal Point (dEc Pt).....23
 - Programming the Meter (PrOG)23
 - Setting the Display Parameter & Intensity (dSPLRy)25
 - Display Intensity (d-IntY).....25
 - Setting the Relay Operation (rELAY).....26
 - Setting the Relay Assignment (R55, r5n).....26
 - Setting the Relay Action.....26
 - Programming Set and Reset Points27
 - Setting Fail-Safe Operation.....27
 - Programming Time Delay.....27
 - Relay Action for Loss of 4-20 mA Input (Loop Break)27
 - Relay and Alarm Operation Diagrams27
 - High Alarm Operation (Set > Reset)27
 - Low Alarm Operation (Set < Reset)28
 - High Alarm with Fail-Safe Operation (Set > Reset).....28

- Low Alarm with Fail-Safe Operation (Set < Reset)28
- Time Delay Operation28
- Pump Alternation Control Operation29
- Relay Sampling Operation29
- Relay Operation Details30**
 - Overview30
 - Relays Auto Initialization30
 - Fail-Safe Operation30
 - Front Panel LEDs30
 - Latching and Non-Latching Relay Operation30
 - Non-Latching Relay (Rout)31
 - Non-Latching Relay with Manual Reset (R-nRn)31
 - Latching Relay (LRcH)31
 - Latching Relay with Clear (Lc-Lr)31
 - Acknowledging Relays31
 - Pump Alternation Control Applications (RLtErn)32
 - Setting Up the Interlock Relay (Force On) Feature32
- Scaling the 4-20 mA Analog Output (Rout)33**
- Reset Menu (rESEt)33**
- Manual Control Menu (Control)33**
- Setting Up the Password (PR55)34**
 - Protecting or Locking the Meter34
 - Making Changes to a Password Protected Meter34
 - Disabling Password Protection34
- Advanced Features Menu35**
 - Advanced Features Menu & Display Messages35
 - Noise Filter (FiltEr)36
 - Noise Filter Bypass (bYP55)36
 - Rounding Feature (round)37
 - Modbus RTU Serial Communications (5Er RL)37
 - Select Menu (5EL EcE)37
 - Input Signal Conditioning (FuncEtn)37
 - Multi-Point Linearization (LnErR)38
 - Math Function (nRtEh)39
 - Math Constants (ConSt)39
 - Low-Flow Cutoff (LwFF)39
 - Analog Output Programming (RoutPr)39
 - Programmable Function Keys User Menu (u5Er)40
 - Tare (tRrE R, tRrE b)41
 - Internal Calibration (iERL)41
- Meter Operation42**
 - Front Panel Buttons Operation42**
 - Function Keys Operation42**
 - F4 Operation42**
 - Maximum/Minimum Readings42**
- Troubleshooting43**
 - Diagnostics Menu (dRd)43**
 - Determining Software Version43
 - Reset Meter to Factory Defaults43**
 - Factory Defaults & User Settings43
 - Troubleshooting Tips45**
- EU Declaration of Conformity46**

Table of Figures

Figure 1. 1/8 DIN Panel Cutout Dimensions	12
Figure 2. Panel Mounting Details	12
Figure 3. Meter Dimensions - Side View	12
Figure 4. Meter Dimensions - Top View	12
Figure 5. Transmitter Supply Voltage Selection	14
Figure 6. PD6060-##0 Connectors Label	14
Figure 7. PD6060-##2 Connectors Label	14
Figure 8. PD6060-##3 Connectors Label	14
Figure 9. PD6060-##4 Connectors Label	14
Figure 10. PD6060-##5 Connectors Label	14
Figure 11. PD6060-##7 Connectors Label	14
Figure 12. Power Connections	15
Figure 13. Transmitters Powered by Internal Supply	15
Figure 14. Transmitter Powered by Ext. Supply or Self-Powered	15
Figure 15. Voltage Input Connections	15
Figure 16. Relay Connections.....	15
Figure 17. AC and DC Loads Protection.....	16
Figure 18. Low Voltage DC Loads Protection	16
Figure 19. F4 Digital Input Connections	16
Figure 20. 4-20 mA Output Connections	16
Figure 21. Analog Output Supply Powering Other Devices.....	16
Figure 22. Expansion Module & DIN Rail Mounting Kit.....	17
Figure 23. External Relays Module Connections.....	17
Figure 24. Digital I/O Module Connections.....	17
Figure 25. Dual 4-20 mA Output Module Connections.....	17
Figure 26. Interlock Connections	17

Introduction

The ProVu PD6060 is a multipurpose, easy to use digital dual-input process meter ideal for level, flow rate, temperature transmitter, or pressure transmitter applications. Its superluminous LED digits make it easily readable in smoke, dust, fog, and, with the optional SunBright display, even direct sunlight. It accepts current and voltage signals (e.g. 4-20 mA, 0-10 V). Various math functions may be applied to the inputs including addition, difference, absolute difference, average, weighted average, multiplication, division, minimum, maximum, draw, ratio, and concentration. This is in addition to the input signal conditioning functions (linear, square root, programmable exponent, or round horizontal tank calculations).

The displays, relays, and the analog output may be assigned to input channels A or B, or math result channel C.

Three of the front panel buttons can be custom-programmed for a specific operation.

The basic model includes an isolated 24 VDC transmitter power supply that can be used to power the input transmitters or other devices. An additional isolated 24 VDC power supply is included with the 4-20 mA output option. A digital input is standard.

A fully loaded PD6060 meter has the following: four SPDT relays, 4-20 mA output, and two 24 VDC power supplies. The PD6060 capabilities may be enhanced by adding the following external expansion modules: four SPST relays –creating an eight-relay dual-input process meter, two digital I/O modules with four inputs and four outputs each, serial communication adapters for use with MeterView Pro or Modbus RTU, and a dual 4-20 mA output expansion module.

Ordering Information

Standard Models

85-265 VAC Model	12-24 VDC Model	Options Installed
PD6060-6R0	PD6060-7R0	No options
PD6060-6R2	PD6060-7R2	2 relays
PD6060-6R3	PD6060-7R3	4-20 mA output
PD6060-6R4	PD6060-7R4	4 relays
PD6060-6R5	PD6060-7R5	2 relays & 4-20 mA output
PD6060-6R7	PD6060-7R7	4 relays & 4-20 mA output

SunBright Display Models

85-265 VAC Model	12-24 VDC Model	Options Installed
PD6060-6H0	PD6060-7H0	No options
PD6060-6H2	PD6060-7H2	2 relays
PD6060-6H3	PD6060-7H3	4-20 mA output
PD6060-6H4	PD6060-7H4	4 relays
PD6060-6H5	PD6060-7H5	2 relays & 4-20 mA output
PD6060-6H7	PD6060-7H7	4 relays & 4-20 mA output

Accessories

Model	Description
PDA1002	DIN rail mounting kit for two devices
PDA1004	4 SPST (Form A) relays
PDA1011	Dual isolated analog output
PDA1044	4 digital inputs & 4 digital outputs
PDA1232	RS-232 serial adapter
PDA1485	RS-485 serial adapter
PDA7485-I	RS-232 to RS-485 isolated converter
PDA8008	USB Adapter
PDA8232-N	USB to RS-232 non-isolated converter
PDA8485-I	USB to RS-485 isolated converter
PDA-LH	Light / horn accessory
MOD-LH	Light / horn / enclosure modification
PD659	Signal isolators, splitters, & conditioners
PDA2360	Plastic control stations series
PD9501	Multi-function calibrator
PD9502	Low-cost signal generator
PDX6901	Snubber: 0.01 µF/470 Ω, 250 VAC

Enclosures

Series	Meters	Material
PDA2300	1-10	Plastic NEMA 4X
PDA2500	1-6	Plastic NEMA 4X
PDA2600	1-6	Stainless Steel NEMA 4X
PDA2700	1-6	Painted Steel NEMA 4
PDA2800	1-2	Plastic NEMA 4X
PDA3400	1-3	Plastic NEMA 4X

Need help selecting the right enclosure?
Go to www.predig.com/esu

Replacement Option Cards

Model	Options Installed
PD1102	2 relays
PD1103	4-20 mA output
PD1104	4 relays
PD1105	2 relays & 4-20 mA output
PD1107	4 relays & 4-20 mA output

Specifications

Except where noted all specifications apply to operation at +25°C.

General

Display	Line 1: 0.60" (15 mm) high, red LEDs Line 2: 0.46" (12 mm) high, red LEDs 6 digits each (-99999 to 999999), with lead zero blanking
Display Intensity	Eight user selectable intensity levels. Default value is six.
Display Update Rate	5/second (200 ms)
Overrange	Display flashes 99999
Underrange	Display flashes -99999
Display Assignment	Display lines 1 & 2 may be assigned to process values for Channels A (Ch-A), B (Ch-B), or C (Ch-C), toggle between (Ch-A & Ch-B, Ch-A & Ch-C, Ch-B & Ch-C, and Ch-A, Ch-B, & Ch-C), toggle between Channel & units, show channel gross value (no tare) or toggle net (tared) and gross values, show relay set points, max & min values, or Modbus input. Line 2 may also be set to show engineering units or be off, with no display.
Programming Methods	Four front panel buttons, digital inputs, PC and MeterView Pro software, or Modbus registers.
Noise Filter	Programmable from 2 to 199 (0 will disable filter)
Filter Bypass	Programmable from 0.1 to 99.9% of calibrated span
Recalibration	All ranges are calibrated at the factory. Recalibration is recommended at least every 12 months.
Max/Min Display	Max/min readings reached by the process are stored until reset by the user or until power to the meter is cycled.
Rounding	Select 1, 2, 5, 10, 20, 50, or 100 (e.g. rounding = 10, value = 123.45, display = 123.50).
Tare	Tare function zeros out the meter to accommodate for weight of a container. Tare function can be assigned to a function key, F4 terminal, or a digital input. There are two tare functions: Capture Tare for channel A and B, and Reset Tare. See <i>Tare (t Rr E R, t Rr E b)</i> on page 41 for details.
Reset Tare	Clears the tare function and returns the display to the value without tare (gross). Accessed via the Reset menu, function key, or digital input.
Password	Three programmable passwords restrict modification of programmed settings. Pass 1: Allows use of function keys and digital inputs Pass 2: Allows use of function keys, digital inputs and editing set/reset points Pass 3: Restricts all programming, function keys, and digital inputs.

Non-Volatile Memory	All programmed settings are stored in non-volatile memory for a minimum of ten years if power is lost.
Power Options	85-265 VAC 50/60 Hz; 90-265 VDC, 20 W max; 12-24 VDC, 12-24 VAC, 15 W max. Powered over USB for configuration only.
Fuse	Required external fuse: UL Recognized, 5 A max, slow blow; up to 6 meters may share one 5 A fuse
Normal Mode Rejection	Greater than 60 dB at 50/60 Hz
Isolation	4 kV input/output-to-power line 500 V input-to-output or output-to-P+ supply
Overvoltage Category	Installation Overvoltage Category II: Local level with smaller transient overvoltages than Installation Overvoltage Category III.
Environmental	Operating temperature range: -40 to 65°C Storage temperature range: -40 to 85°C Relative humidity: 0 to 90% non-condensing
Connections	Removable screw terminal blocks accept 12 to 22 AWG wire, RJ45 for external relays, digital I/O, and serial communication adapters.
Enclosure	1/8 DIN, high impact plastic, UL 94V-0, color: black
Front Panel	NEMA 4X, IP65
Mounting	1/8 DIN panel cutout required: 3.622" x 1.772" (92 mm x 45 mm) Two panel mounting bracket assemblies are provided.
Tightening Torque	Screw terminal connectors: 5 lb-in (0.56 Nm)
Overall Dimensions	4.68" x 2.45" x 5.64" (119 mm x 62 mm x 143 mm) (W x H x D)
Weight	9.5 oz. (269 g)
Warranty	3 years parts & labor. See Warranty Information and Terms & Conditions on www.predig.com for complete details.

Dual Process Input

Two Inputs	Two non-isolated inputs, independent, field selectable: 0-20 mA, 4-20 mA, ±10 V (0-5 V, 1-5 V, 0-10 V), Modbus PV (Slave)																																										
Isolated Transmitter Power Supply	Terminals P+ & P-: 24 VDC ±10%. All models selectable for 24, 10, or 5 VDC supply (internal jumper J4). 85-265 VAC models rated @ 200 mA max, 12-24 VDC powered models rated @ 100 mA max. 5 & 10 VDC supply rated @ 50 mA max. Refer to <i>Transmitter Supply Voltage Selection (P+, P-)</i> on page 14. When the Light / Horn is powered by the transmitter power supply, see MOD-LH Light / Horn's transmitter power supply specification in MOD-LH manual for additional details. Light / Horn power not available for 5 or 10 VDC supplies.																																										
Channels	Channel A, Channel B, Channel C (Math channel)																																										
Programmable Constants	Constant P (Adder): -99.999 to 999.999, default: 0.000 Constant F (Factor): 0.001 to 999.999, default: 1.000																																										
Math Functions	<table border="1"> <thead> <tr> <th>Name</th> <th>Function</th> <th>Setting</th> </tr> </thead> <tbody> <tr> <td>Addition</td> <td>$(A+B+P)*F$</td> <td>5000</td> </tr> <tr> <td>Difference</td> <td>$(A-B+P)*F$</td> <td>d i F</td> </tr> <tr> <td>Absolute diff.</td> <td>$((Abs(A-B))+P)*F$</td> <td>d i F R b 5</td> </tr> <tr> <td>Average</td> <td>$((A+B)/2+P)*F$</td> <td>R u 0</td> </tr> <tr> <td>Multiplication</td> <td>$(A*B+P)*F$</td> <td>n r u L t i</td> </tr> <tr> <td>Division</td> <td>$(A/B+P)*F$</td> <td>d i 0 d E</td> </tr> <tr> <td>Max of A or B</td> <td>$((AB-Hi)+P)*F$</td> <td>H i - R b</td> </tr> <tr> <td>Min of A or B</td> <td>$((AB-Lo)+P)*F$</td> <td>L o - R b</td> </tr> <tr> <td>Draw</td> <td>$(A/B)-1)*F$</td> <td>d r R u j</td> </tr> <tr> <td>Weighted avg.</td> <td>$((B-A)*F)+A$</td> <td>u j R u 0</td> </tr> <tr> <td>Ratio</td> <td>$(A/B)*F$</td> <td>r R t i o</td> </tr> <tr> <td>Ratio 2</td> <td>$((B-A)/A+P)*F$</td> <td>r R t i o 2</td> </tr> <tr> <td>Concentration</td> <td>$A/(A+B)*F$</td> <td>C o n c E n</td> </tr> </tbody> </table> <p><i>Note: The F constant can be any value from 0.001 to 999.999. If the value is less than 1, it will have the same effect as a divider (1/F). For example, the average could also be derived by using $(A+B)*0.5 F = (A+B)/2$</i></p>	Name	Function	Setting	Addition	$(A+B+P)*F$	5000	Difference	$(A-B+P)*F$	d i F	Absolute diff.	$((Abs(A-B))+P)*F$	d i F R b 5	Average	$((A+B)/2+P)*F$	R u 0	Multiplication	$(A*B+P)*F$	n r u L t i	Division	$(A/B+P)*F$	d i 0 d E	Max of A or B	$((AB-Hi)+P)*F$	H i - R b	Min of A or B	$((AB-Lo)+P)*F$	L o - R b	Draw	$(A/B)-1)*F$	d r R u j	Weighted avg.	$((B-A)*F)+A$	u j R u 0	Ratio	$(A/B)*F$	r R t i o	Ratio 2	$((B-A)/A+P)*F$	r R t i o 2	Concentration	$A/(A+B)*F$	C o n c E n
Name	Function	Setting																																									
Addition	$(A+B+P)*F$	5000																																									
Difference	$(A-B+P)*F$	d i F																																									
Absolute diff.	$((Abs(A-B))+P)*F$	d i F R b 5																																									
Average	$((A+B)/2+P)*F$	R u 0																																									
Multiplication	$(A*B+P)*F$	n r u L t i																																									
Division	$(A/B+P)*F$	d i 0 d E																																									
Max of A or B	$((AB-Hi)+P)*F$	H i - R b																																									
Min of A or B	$((AB-Lo)+P)*F$	L o - R b																																									
Draw	$(A/B)-1)*F$	d r R u j																																									
Weighted avg.	$((B-A)*F)+A$	u j R u 0																																									
Ratio	$(A/B)*F$	r R t i o																																									
Ratio 2	$((B-A)/A+P)*F$	r R t i o 2																																									
Concentration	$A/(A+B)*F$	C o n c E n																																									
Sequence of Operations for Input Programming	<ol style="list-style-type: none"> 1. Select Input for A and B 2. Set up the engineering units for A, B, and C 3. Set up decimal point for A, B, and C 4. Program A & B 5. Set up the displays for A, B, or C 6. Select the transfer function for A & B (e.g. Linear) 7. Select Math function for Channel C 8. Program constants for Factor (F) and Adder (P). 9. Program cutoff values for A and B 																																										
Accuracy	±0.03% of calibrated span ±1 count, square root & programmable exponent accuracy range: 10-100% of calibrated span																																										
Temperature Drift	0.005% of calibrated span/°C max from 0 to 65°C ambient, 0.01% of calibrated span/°C max from -40 to 0°C ambient																																										

Input Signal Conditioning	Linear, square root, programmable exponent, or round horizontal tank volume calculation						
Multi-Point Linearization	2 to 32 points for channel A and B						
Programmable Exponent	User selectable from 1.0001 to 2.9999 for open channel flow						
Low-Flow Cutoff	0.0 to 999,999.9 (0 disables cutoff function). Point below at which display always shows zero.						
Decimal Point	Up to five decimal places or none: d d d d d d, d d d d d, d d d d, d d d, d d, or d d d d d d						
Calibration Range	<table border="1"> <thead> <tr> <th>Input Range</th> <th>Minimum Span Input 1 & 2</th> </tr> </thead> <tbody> <tr> <td>4-20 mA</td> <td>0.15 mA</td> </tr> <tr> <td>±10 V</td> <td>0.10 V</td> </tr> </tbody> </table> <p>An error message will appear if the input 1 and input 2 signals are too close together.</p>	Input Range	Minimum Span Input 1 & 2	4-20 mA	0.15 mA	±10 V	0.10 V
Input Range	Minimum Span Input 1 & 2						
4-20 mA	0.15 mA						
±10 V	0.10 V						
Input Impedance	Voltage ranges: greater than 500 kΩ Current ranges: 50 - 100 Ω (depending on resettable fuse impedance)						
Input Overload	Current input protected by resettable fuse, 30 VDC max. Fuse resets automatically after fault is removed.						
HART Incompatible	<p>The meter can support ONLY one HART loop on either of the inputs. A signal isolator, such as the PD659 is required if two HART loops are being connected.</p> <p>Under the described conditions, the meter does not interfere with existing HART communications; it displays the 4-20 mA primary variable and it allows the HART communications to pass through without interruption. The meter is not affected if a HART communicator is connected to the loop. The meter does not display secondary HART variables.</p>						

Relays

Rating	2 or 4 SPDT (Form C) internal and/or 4 SPST (Form A) external; rated 3 A @ 30 VDC and 125/250 VAC resistive load; 1/14 HP (≈ 50 W) @ 125/250 VAC for inductive loads
Noise Suppression	Noise suppression is recommended for each relay contact switching inductive loads. See <i>Switching Inductive Loads</i> on page 15 for details.
Deadband	0-100% of span, user programmable
High or Low Alarm	User may program any alarm for high or low trip point. Unused alarm LEDs and relays may be disabled (turn off).
Relay Operation	<ul style="list-style-type: none"> • Automatic (non-latching) and/or manual reset • Latching (requires manual acknowledge) with or without clear • Pump alternation control (2-8 relays) • Sampling (based on set point and time) • Off (disable unused relays and enable Interlock feature) • Manual on/off control mode
Relay Reset	User selectable via front panel button, F4 terminal at back of meter, external contact closure on digital inputs, or through serial communications
Time Delay	0 to 999.9 seconds, on & off relay time delays. Programmable and independent for each relay
Fail-Safe Operation	Programmable and independent for each relay. <i>Note: Relay coil is energized in non-alarm condition. In case of power failure, relay will go to alarm state.</i>
Auto Initialization	When power is applied to the meter, relays will reflect the state of the input to the meter.
Additional Relays	An external module, model PDA1004 , is available to add 4 SPST 3 A relays to the meter.

Isolated 4-20 mA Transmitter Output

Output Source	Process channel A, B, or C, max or min for channel A, B, or highest or lowest of A and B, set points 1-8, Modbus input, or manual control mode									
Scaling Range	1.000 to 23.000 mA for any display range									
Calibration	Factory calibrated: 4.000 to 20.000 = 4-20 mA output									
Analog Out Programming	23.000 mA maximum for all parameters: Overrange, underrange, max, min, and break									
Accuracy	± 0.1% of span ± 0.004 mA									
Temperature Drift	0.4 µA/°C max from 0 to 65°C ambient, 0.8 µA/°C max from -40 to 0°C ambient <i>Note: Analog output drift is separate from input drift.</i>									
Isolated Transmitter Power Supply	Terminals I+ & R: 24 VDC ± 10%. May be used to power the 4-20 mA output or other devices. All models rated @ 40 mA max.									
External Loop Power Supply	35 VDC maximum									
Output Loop Resistance	<table border="1"> <thead> <tr> <th>Power supply</th> <th>Minimum</th> <th>Maximum</th> </tr> </thead> <tbody> <tr> <td>24 VDC</td> <td>10 Ω</td> <td>700 Ω</td> </tr> <tr> <td>35 VDC (external)</td> <td>100 Ω</td> <td>1200 Ω</td> </tr> </tbody> </table>	Power supply	Minimum	Maximum	24 VDC	10 Ω	700 Ω	35 VDC (external)	100 Ω	1200 Ω
Power supply	Minimum	Maximum								
24 VDC	10 Ω	700 Ω								
35 VDC (external)	100 Ω	1200 Ω								
0-10 VDC Output	The PD659-1MA-1V can convert the optional 4-20 mA output to a 0-10 VDC output									
Additional 4-20 mA Outputs	An external module, model PDA1011 , is available to add two 4-20 mA outputs to the meter.									

USB Connection

Function	Programming only
Compatibility	USB 2.0 Standard, Compliant
Connector Type	Micro-B receptacle
Cable	USB A Male to Micro-B Cable
Driver	Microsoft® Windows® XP/Vista/7/8/10
Power	USB port provides power to the meter. DO NOT apply AC or DC power to the meter while the USB port is in use.

On-Board Digital Input (F4)

Function	Remote operation of front-panel buttons, acknowledge/reset relays, reset max/min values. See <i>Function Keys & Digital I/O Available Settings</i> on page 40 for a complete list of capabilities.
Contacts	3.3 VDC on contact. Connect normally open contacts across F4 to COM
Logic Levels	Logic High: 3 to 5 VDC Logic Low: 0 to 1.25 VDC
Additional I/O	Up to 2 external modules, model PDA1044 with 4 digital inputs and 4 digital outputs each can be added.

Modbus® RTU Serial Communications

Slave Id	1 – 247 (Meter address)
Baud Rate	300 – 19,200 bps
Transmit Time Delay	Programmable between 0 and 199 ms
Data	8 bit (1 start bit, 1 or 2 stop bits)
Parity	Even, Odd, or None with 1 or 2 stop bits
Byte-To-Byte Timeout	0.01 – 2.54 second
Turn Around Delay	Less than 2 ms (fixed)

Note: Refer to the ProVu Modbus Register Tables located at www.predig.com for details.

MeterView Pro

Availability	Download directly from meter or from www.predig.com/download_software
System Requirements	Microsoft® Windows® XP/Vista/7/8/10
Communications	USB 2.0 (for programming only) (Standard USB A to Micro USB B) RS-232 adapter, RS-485 adapter and RS-485 to USB converter (programming, monitoring, and data logging)
Configuration	Configure meters one at a time
Power	USB port provides power to the meter. DO NOT apply AC or DC power to the meter while the USB port is in use.

Compliance Information

Safety

UL & c-UL Listed	USA & Canada UL 508 Industrial Control Equipment
UL File Number	E160849
Front Panel	UL Type 4X, NEMA 4X, IP65; panel gasket provided
Low Voltage Directive	EN 61010-1:2010 Safety requirements for measurement, control, and laboratory use

Electromagnetic Compatibility

Emissions	EN 55022:2010 Class A ITE emissions requirements
Radiated Emissions	Class A
AC Mains Conducted Emissions	Class A
Immunity	EN 61326-1:2013 Measurement, control, and laboratory equipment EN 61000-6-2:2005 EMC heavy industrial generic immunity standard
RFI - Amplitude Modulated	80 -1000 MHz 10 V/m 80% AM (1 kHz) 1.4 - 2.0 GHz 3 V/m 80% AM (1 kHz) 2.0 - 2.7 GHz 1 V/m 80% AM (1 kHz)
Electrical Fast Transients	±2kV AC mains, ±1kV other
Electrostatic Discharge	±4kV contact, ±8kV air
RFI - Conducted	10V, 0.15-80 MHz, 1kHz 80% AM
AC Surge	±2kV Common, ±1kV Differential
Surge	1KV (CM)
Power-Frequency Magnetic Field	30 A/m 70%V for 0.5 period
Voltage Dips	40%V for 5 & 50 periods 70%V for 25 periods
Voltage Interruptions	<5%V for 250 periods

Note:

Testing was conducted on meters installed through the covers of grounded metal enclosures with cable shields grounded at the point of entry representing installations designed to optimize EMC performance.

Safety Information

⚠ CAUTION

- Read complete instructions prior to installation and operation of the meter.

⚠ WARNINGS

- Risk of electric shock or personal injury.
- Hazardous voltages exist within enclosure. Installation and service should be performed only by trained service personnel.

Installation

There is no need to remove the meter from its case to complete the installation, wiring, and setup of the meter for most applications.

Instructions are provided for changing the transmitter power supply to output 5 or 10 VDC instead of 24 VDC. See *Figure 5. Transmitter Supply Voltage Selection* on page 14.

Unpacking

Remove the meter from box. Inspect the packaging and contents for damage. Report damages, if any, to the carrier.

If any part is missing or the meter malfunctions, please contact your supplier or the factory for assistance.

Panel Mounting Instructions

- Prepare a standard 1/8 DIN panel cutout - 3.622" x 1.772" (92 mm x 45 mm). Refer to Figure 1. 1/8 DIN Panel Cutout Dimensions below for more details.
- Clearance: allow at least 6.0" (152 mm) behind the panel for wiring.
- Panel thickness: 0.04" - 0.25" (1.0 mm - 6.4 mm). Recommended minimum panel thickness to maintain Type 4X rating: 0.06" (1.5 mm) steel panel, 0.16" (4.1 mm) plastic panel.
- Remove the two mounting brackets provided with the meter (back-off the two screws so that there is ¼" (6.4 mm) or less through the bracket. Slide the bracket toward the front of the case and remove).
- Insert meter into the panel cutout.
- Install mounting brackets and tighten the screws against the panel. To achieve a proper seal, tighten the mounting bracket screws evenly until meter is snug to the panel along its short side. DO NOT OVER TIGHTEN, as the rear of the panel may be damaged.

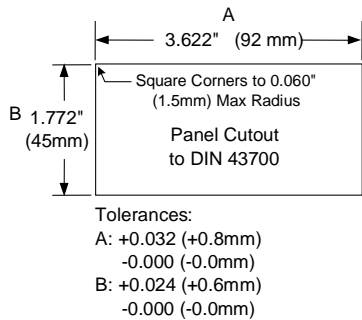
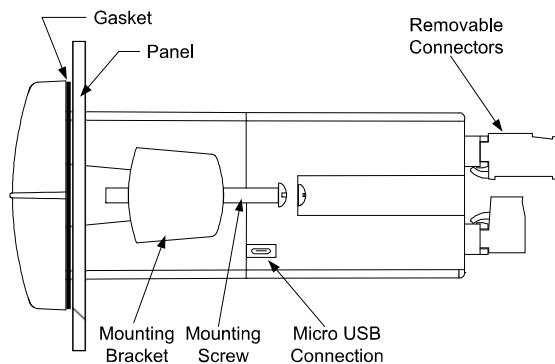

Figure 1. 1/8 DIN Panel Cutout Dimensions



DO NOT apply AC or DC power to the meter when using the Micro USB connection.

Figure 2. Panel Mounting Details

Mounting Dimensions

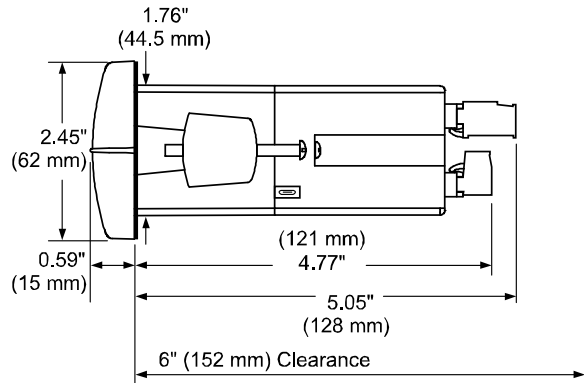

Figure 3. Meter Dimensions - Side View

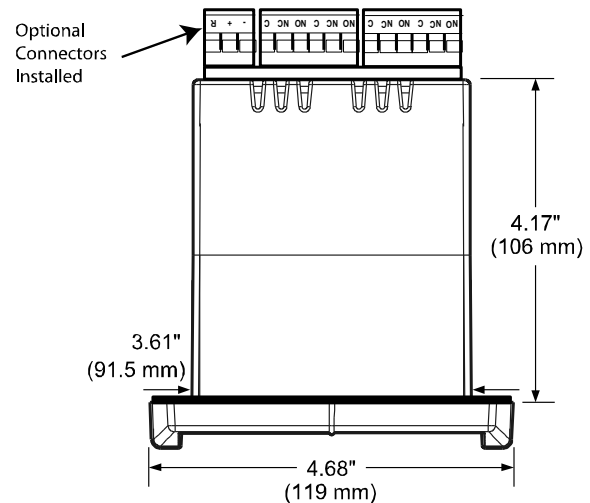

Figure 4. Meter Dimensions - Top View

ENCLOSURE CAD DIMENSIONAL DRAWINGS

Download free 3-D CAD files of these instruments to simplify your drawings!

predig.com/documentation-cad

Installation Overview

We recommend the following sequence for getting the meter into service:

1. **DO NOT** apply AC or DC power to the meter.
2. Connect the meter to the PC with the USB cable provided. **DO NOT** use a different USB cable.
3. If MeterView Pro (MVPro) is already installed in your computer, then the program will launch automatically in most systems. If the program does not start automatically, double-click on the MVPro icon.
4. If MVPro is not installed, follow the instructions provided below.
5. Use MVPro to configure the meter for your application.
6. Disconnect the USB cable from the meter.
7. Apply power and signal and check operation of the meter.
8. Install the meter and put into service.
9. Make any programming adjustments using the front panel buttons.

MeterView Pro Software

The easiest and quickest way to program your PROVu meter is to use the FREE MeterView Pro programming software. This software is loaded into the meter and connects and installs directly to your PC with the USB cable provided. **DO NOT** use a different USB cable. We recommend that the first thing you do after taking the meter out of the box is connect the PROVu to your PC with the provided USB cable. **DO NOT** apply AC or DC power to the meter while your PC is connected to the meter as it will disrupt the USB connection. It is not necessary to apply an input signal.

MeterView Pro programming software is intuitive, and most customers can get their meter programmed as they like without even looking in the manual.

Watch Meterview Pro Software Video at www.predig.com/meterviewpro

MeterView Pro Installation

1. Connect one end of the provided USB cable to the meter and the other end to the computer. The computer will automatically install the driver software it needs to talk to the meter. Follow the on-screen instructions and allow sufficient time for the process to complete. This can take a few minutes. If the process is interrupted, then it could leave the system in an unstable condition.

⚠ WARNINGS

- Only one meter may be connected at a time. Attaching multiple meters will cause a conflict with the meter software.
- **DO NOT** apply AC or DC power to the meter when using the Micro USB connection.

2. Once the driver is installed, an AutoPlay dialog should appear for the drive "MAINSTAL." Click "Open folder to view files."

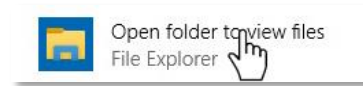

If the computer does not display an AutoPlay dialog for the drive "MAINSTAL," you should open My Computer and double-click on the drive labeled "MAINSTAL."

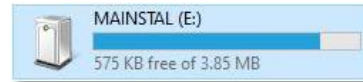

3. Double-click on the file named "MAStart." The program will open a few windows and install two programs on your computer. Simply follow the on-screen instructions until you see one of the dialogs below. If you receive a "User Account Control" warning, click "Yes."

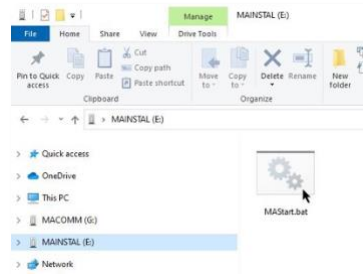

4. If there is an update available, click the "Update" button to install the new version. Otherwise, click "Configure" to begin programming your meter.

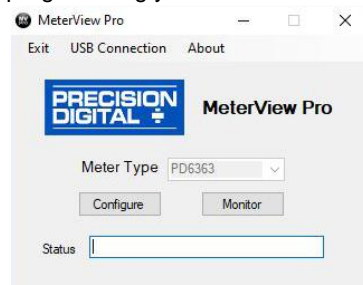

Note: If you decide to update your MeterView Pro software, once the installation has completed, you will be asked if you want to update the setup files located on the meter itself. This way, you will always have the most current version on the meter for future installs.

⚠ WARNING

- **DO NOT** unplug the meter while the new installation files are being written to it. The meter will display μA during the process and you will receive an on-screen notification once the process is complete.

Transmitter Supply Voltage Selection (P+, P-)

All meters, including models equipped with the 12-24 VDC power option, are shipped from the factory configured to provide 24 VDC power for the transmitter or sensor.

If the transmitter requires 5 or 10 VDC excitation, the internal jumper J4 must be configured accordingly.

To access the voltage selection jumper:

1. Remove all the wiring connectors.
2. Unscrew the back cover.
3. Slide out the back cover by about 1 inch.
4. Configure the J4 jumper, located behind the input signal connector, for the desired excitation voltage as shown.

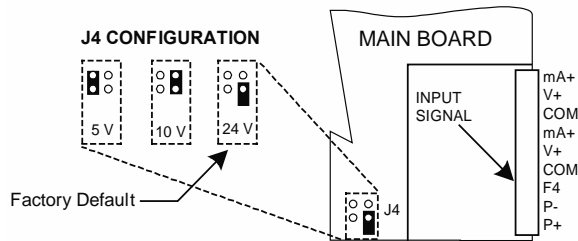

Figure 5. Transmitter Supply Voltage Selection

Connections

All connections are made to removable screw terminal connectors located at the rear of the meter.

CAUTION

- Use copper wire with 60°C or 60/75°C insulation for all line voltage connections. Observe all safety regulations. Electrical wiring should be performed in accordance with all applicable national, state, and local codes to prevent damage to the meter and ensure personnel safety.

Connectors Labeling

The connectors' label, affixed to the meter, shows the location of all connectors available with requested configuration.

Note: ## on the following figures refers to power and display options. (Example: PD6060-6H5)

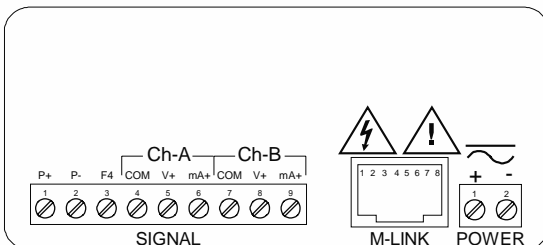

Figure 6. PD6060-##0 Connectors Label

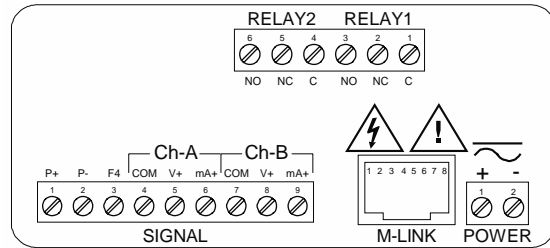

Figure 7. PD6060-##2 Connectors Label

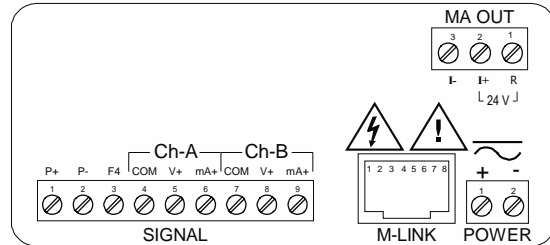

Figure 8. PD6060-##3 Connectors Label

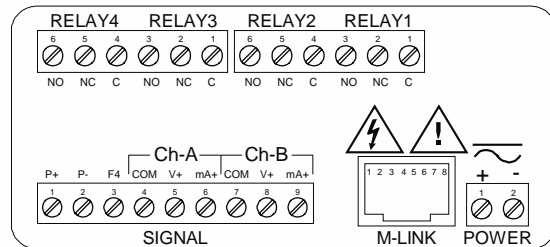

Figure 9. PD6060-##4 Connectors Label

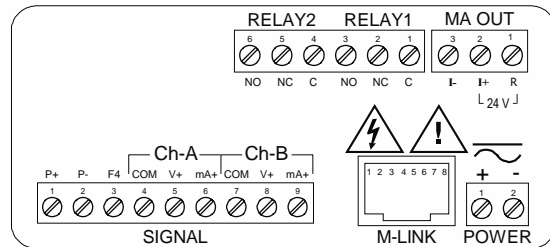

Figure 10. PD6060-##5 Connectors Label

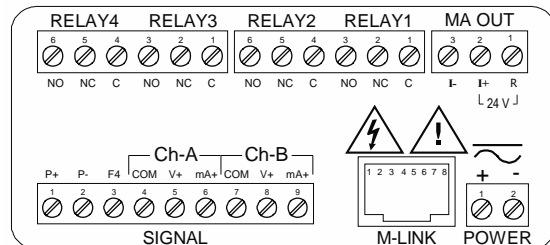

Figure 11. PD6060-##7 Connectors Label

WARNING

- **DO NOT** connect any equipment other than Precision Digital's expansion modules, cables, or meters to the RJ45 M LINK connector. Otherwise damage will occur to the equipment and the meter.

Power Connections

Power connections are made to a two-terminal connector labeled POWER. The meter will operate regardless of DC polarity connection. The + and - symbols are only a suggested wiring convention.

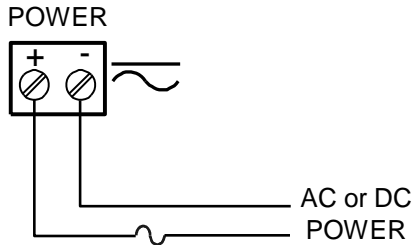

Required External Fuse:
5 A max, 250 V Slow Blow

Figure 12. Power Connections

Signal Connections

Signal connections are made to a nine-terminal connector labeled SIGNAL. The COM (common) terminals are the return for the 4-20 mA and the ±10 V input signals. The two COM terminals connect to the same common return, and are not isolated.

Current and Voltage Connections

The following figures show examples of current and voltage connections. There are no switches or jumpers to set up for current and voltage inputs. Setup and programming is performed through the front panel buttons.

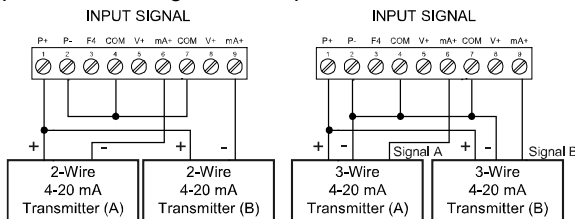

Figure 13. Transmitters Powered by Internal Supply

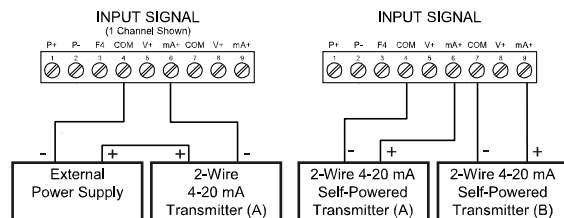

Figure 14. Transmitter Powered by Ext. Supply or Self-Powered

The current input is protected against current overload by a resettable fuse. The display may or may not show a fault condition depending on the nature of the overload.

The fuse limits the current to a safe level when it detects a fault condition, and automatically resets itself when the fault condition is removed.

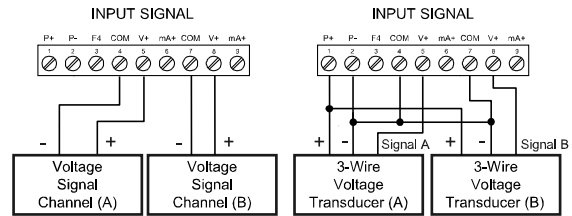

Figure 15. Voltage Input Connections

The meter is capable of accepting any voltage from -10 VDC to +10 VDC.

Modbus RTU Serial Communications

Serial communications connection is made to an RJ45 connector labeled M-LINK. For interfacing to the PROVU, use the PDA1232 for RS-232 or the PDA1485 for RS-485. The same port is used for interfacing with all expansion modules (e.g. external relays, digital I/O).

Relay Connections

Relay connections are made to two six-terminal connectors labeled RELAY1 – RELAY4. Each relay's C terminal is common only to the normally open (NO) and normally closed (NC) contacts of the corresponding relay. The relays' C terminals should not be confused with the COM (common) terminal of the INPUT SIGNAL connector.

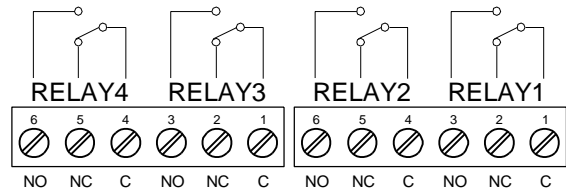

Figure 16. Relay Connections

Switching Inductive Loads

The use of snubbers to suppress electrical noise is strongly recommended when switching inductive loads to prevent disrupting the microprocessor's operation. The snubbers also prolong the life of the relay contacts. Suppression can be obtained with resistor-capacitor (RC) networks assembled by the user or purchased as complete assemblies. Refer to the following circuits for RC network assembly and installation:

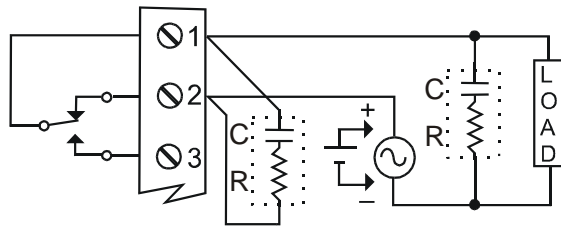

Figure 17. AC and DC Loads Protection

Choose R and C as follows:

R: 0.5 to 1 Ω for each volt across the contacts

C: 0.5 to 1 μF for each amp through closed contacts

Notes:

1. Use capacitors rated for 250 VAC.
2. RC networks may affect load release time of solenoid loads. Check to confirm proper operation.
3. Install the RC network at the meter's relay screw terminals. An RC network may also be installed across the load. Experiment for best results.

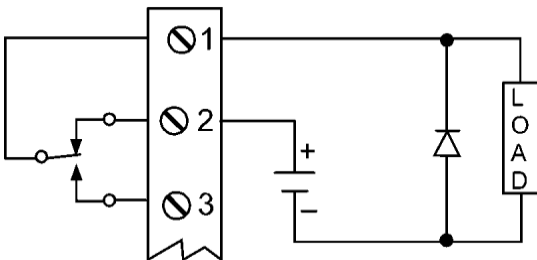

Use a diode with a reverse breakdown voltage two to three times the circuit voltage and forward current at least as large as the load current.

Figure 18. Low Voltage DC Loads Protection

RC Networks (Snubbers) Available from Precision Digital

RC networks are available from Precision Digital and should be applied to each relay contact switching an inductive load. Part number: [PDX6901](#).

Note: Relays are de-rated to 1/14th HP (50 watts) with an inductive load.

F4 Digital Input Connections

A digital input, F4, is standard on the meter. This digital input should be connected with a normally open contact across F4 and COM, or with an active low signal applied to F4. It can be used for remote operation of front-panel buttons, to acknowledge/reset relays, or to reset max/min values. See *Function Keys & Digital I/O Available Settings* on page 40 for a complete list of capabilities.

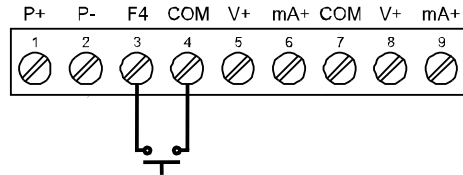

Figure 19. F4 Digital Input Connections

4-20 mA Output Connections

Connections for the 4-20 mA transmitter output are made to the connector terminals labeled mA OUT. The 4-20 mA output may be powered internally or from an external power supply.

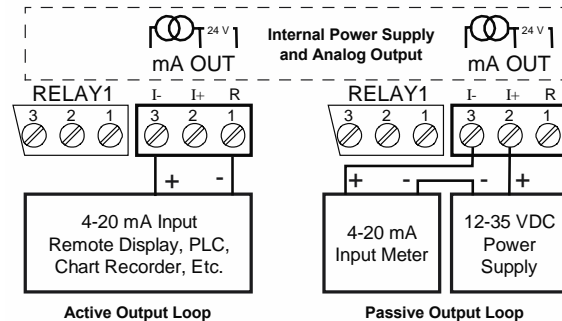

Figure 20. 4-20 mA Output Connections

Analog Output Power Supply

The internal 24 VDC power supply powering the analog output may be used to power other devices, if the analog output is not used. The I+ terminal is the +24 V and the R terminal is the return.

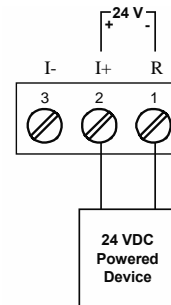

Figure 21. Analog Output Supply Powering Other Devices

External Relay, Analog Output, & Digital I/O Connections

The relay, dual analog output, and digital I/O expansion modules PDA1004, PDA1011, and PDA1044 are connected to the meter using a CAT5 cable provided with each module. The two RJ45 connectors on the expansion modules are identical and interchangeable; they are used to connect additional modules to the system.

Note: The jumper located between the RJ45 connectors of the PDA1044 must be removed on the second digital I/O module in order for the system to recognize it as module #2.

WARNING

- **DO NOT** connect or disconnect the expansion modules with the power on! More detailed instructions are provided with each optional expansion module.



Figure 22. Expansion Module & DIN Rail Mounting Kit

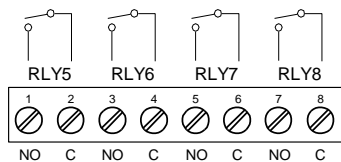

Figure 23. External Relays Module Connections

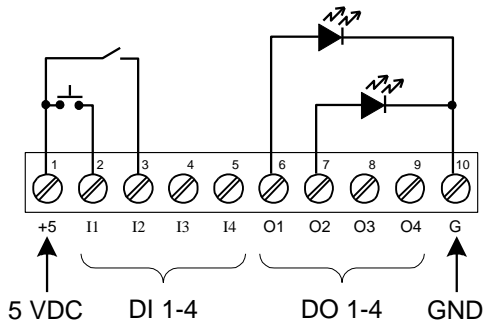

Figure 24. Digital I/O Module Connections

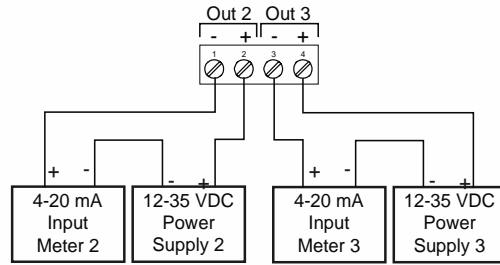

Figure 25. Dual 4-20 mA Output Module Connections

Interlock Relay Feature

As the name implies, the interlock relay feature reassigns one, or more, alarm/control relays for use as interlock relay(s). Interlock contact(s) are wired to digital input(s) and activate the interlock relay. This feature is enabled by configuring the relay, and the corresponding digital input(s), see *Setting Up the Interlock Relay (Force On) Feature* on page 32.

In the example below, an Interlock Contact switch is connected to a digital input, which will be used to force on (energize) the Interlock Relay. The Interlock Relay and the Control Relay are connected in series with the load.

- When the Interlock Contact is closed (safe), the Interlock Relay energizes, allowing power to flow to the Control Relay; the corresponding front panel LED is on.
- When the Interlock Contact is open, the corresponding front panel LED flashes (locked out), the Interlock Relay is de-energized, preventing power from flowing to the Control Relay and the load.

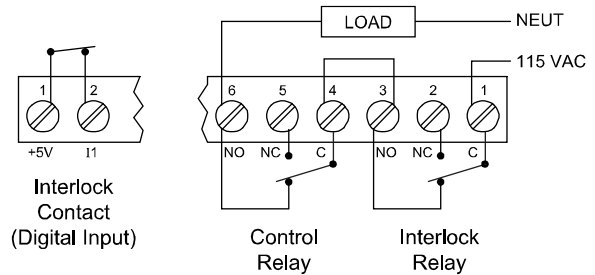

Figure 26. Interlock Connections

Setup and Programming

There is **no need to recalibrate** the meter when first received from the factory.

The meter is **factory calibrated** prior to shipment for milliamps and volts with calibration equipment that is certified to NIST standards.

Overview

There are no jumpers to set for the meter input selection.

Setup and programming is done using MeterView Pro or through the front panel buttons.

After power and input signal connections have been completed and verified, apply power to the meter.

Front Panel Buttons and Status LED Indicators



Button Symbol	Description	LED	Status
	Menu	1-8	Alarm 1-8 indicator
	Right arrow/F1	1-8 M	Flashing: Relay in manual control mode
	Up arrow/F2	A, B, C	Channel displayed Flashing: Tare
	Enter/F3	1-8	Flashing: Relay interlock switch open
<p>Note:</p> <p>F4 is a digital input. Alarms 5-8 are enabled when relay expansion module is installed.</p>		<p>Note:</p> <p>LEDs for relays in manual mode flash with the "M" LED every 10 seconds. "M" flashing by itself indicates Aout – manual control is used.</p>	

- Press the Menu button to enter or exit the Programming Mode at any time.
- Press the Right arrow button to move to the next digit during digit or decimal point programming.
- Press or hold the Up arrow button to scroll through the menus, decimal point, or to increment the value of a digit.
- Press the Enter button to access a menu or to accept a setting.
- Press and hold the Menu button for three seconds to access the advanced features of the meter.

Display Functions & Messages

The following table shows the main menu functions and messages in the order they appear in the menu.

Display Functions & Messages		
Display	Parameter	Action/Setting Description
SETUP	Setup	Enter Setup menu
INPUT	Input	Enter Input selection menu
Ch-A	Input	Set input type for channel A (*or B)
mA	4-20 mA	Set meter for 4-20 mA input
VOLT	0-10 VDC	Set meter for ±10 VDC input
UNIT	Unit	Select the display units/tags
Ch-A	Unit	Set unit or tag for channel A (*or B or C)
DEC Pt	Decimal point	Set decimal point
Ch-A	Decimal point	Set decimal point for channel A (*or B or C)
PROG	Program	Enter the Program menu
INCR	Input calibration	Enter the Input Calibration menu
Ch-A	Input A	Set input type for channel A (*or B)
SCALE A	Scale A	Enter the Scale menu for channel A
SCALE B	Scale B	Enter the Scale menu for channel B
CAL A	Calibrate A	Enter the Calibration menu for channel A
CAL B	Calibrate B	Enter the Calibration menu for channel B
INP 1	Input 1	Calibrate input 1 signal or program input 1 value
DIS 1	Display 1	Program display 1 value
INP 2	Input 2	Calibrate input 2 signal or program input 2 value (up to 32 points)
DIS 2	Display 2	Program display 2 value (up to 32 points)
Error	Error	Error, calibration not successful, check signal or programmed value
DISPLAY	Display	Enter the Display menu
LINE 1	Line 1	Assign line 1 parameter
LINE 2	Line 2	Assign line 2 parameter
Ch-A	Display Ch-A	Assign display to channel A
Ch-B	Display Ch-B	Assign display to channel B
Ch-C	Display Ch-C	Assign display to channel C (math)
AB	Display AB	Alternate display of channel A & B
AC	Display AC	Alternate display of channel A & C
BC	Display BC	Alternate display of channel B & C

Display Functions & Messages		
Display	Parameter	Action/Setting Description
ABC	Display ABC	Alternate display of channel A, B, & C
REL 1	Display set 1*	Displays relay 1(*through 8) set point.
Hi-A	Display high A	Display high value of channel A
Lo-A	Display low A	Display low value of channel A
Hi/Lo-A	Display hi/low A	Alternate between high/low value of channel A
Hi-B	Display high B	Display high value of channel B
Lo-B	Display low B	Display low value of channel B
Hi/Lo-B	Display high/low B	Alternate between high/low value of channel B
Hi-C	Display high C	Display high value of channel C
Lo-C	Display low C	Display low value of channel C
Hi/Lo-C	Display high/low C	Alternate between high/low value of channel C
A-U	Display A and units/tags	Alternate display of channel A and the unit/tag
B-U	Display B and units/tags	Alternate display of channel B and the unit/tag
C-U	Display C and units/tags	Alternate display of channel C and the unit/tag
A Gross	Display A gross	Display input channel A gross (no tare)
A Net and Gross	Display A net and gross	Alternate display of channel A net (tare) and gross (no tare)
B Gross	Display B gross	Display input channel B gross (no tare)
B Net and Gross	Display B net and gross	Alternate display of channel B net (tare) and gross (no tare)
MODBUS	Display Modbus	Display Modbus input register
OFF	Display off	Display blank (line 2)
UNIT	Display unit	Display line 1 channel units
INTEN	Display intensity	Set display intensity level from 1 to 8
RELAY	Relay	Enter the Relay menu
ASSIGN	Assignment	Assign relays to channels or Modbus
ASSIGN 1	Assign 1	Relay 1 assignment
Ch-A	Channel A*	Assign relay to channel A (*or B or C)
MODBUS	Modbus	Assign relay to Modbus register
RELAY 1	Relay 1	Relay 1 setup
ACTION 1	Action 1	Set relay 1 action

Display Functions & Messages		
Display	Parameter	Action/Setting Description
RuLo	Automatic	Set relay for automatic reset
R-nrRn	Auto-manual	Set relay for auto or manual reset any time
LREtH	Latching	Set relay for latching operation
Lt-CLr	Latching-cleared	Set relay for latching operation with manual reset only after alarm condition has cleared
RLtErn	Alternate	Set relay for pump alternation control
SRnPL	Sample	Set relay for sample time trigger control
OFF	Off	Turn relay off
FRILSF	Fail-safe	Enter Fail-safe menu
FLS 1	Fail-safe 1	Set relay 1 (*through 8) fail-safe operation
on	On	Enable fail-safe operation
oFF	Off	Disable fail-safe operation
dELAY	Delay	Enter relay Time Delay menu
dLY 1	Delay 1	Enter relay 1 time delay setup
On 1	On 1	Set relay 1 On time delay
OFF 1	Off 1	Set relay 1 Off time delay
dLY 2	Delay 2	Enter relays 2-8 time delay setup
brERH	Loop break	Set relay condition if loop break detected
Ignore	Ignore	Ignore loop break condition (Processed as a low signal condition)
On	On	Relay goes to alarm condition when loop break detected
OFF	Off	Relay goes to non-alarm condition when loop break detected
Rout	Analog output	Enter the Analog output scaling menu
ROut 1	Aout channel	Analog Output source channel (*1-3)
d.S 1	Display 1	Program display 1 value
Out 1	Output 1	Program output 1 value (e.g. 4.000 mA)
d.S 2	Display 2	Program display 2 value
Out 2	Output 2	Program output 2 value (e.g. 20.000 mA)
rESEt	Reset	Press Enter to access the Reset menu
rSt H	Reset high	Press Enter to reset max display
rSt Lo	Reset low	Press Enter to reset min display

Display Functions & Messages		
Display	Parameter	Action/Setting Description
rSt HL	Reset high & low	Press Enter to reset max & min displays
rSt tr	Reset tare	Press Enter to reset (cancel) tare
Control	Control	Enter Control menu
RuLo	Automatic	Press Enter to set meter for automatic operation
nrRn	Manual	Press Enter to manually control relays or analog output operation
PRSS	Password	Enter the Password menu
PRSS 1	Password 1*	Set or enter Password 1 (*through 3)
unLoc	Unlocked	Program password to lock meter
Locd	Locked	Enter password to unlock meter
999999 -999999	Flashing	Over/under range condition

Main Menu

The main menu consists of the most commonly used functions: *Reset*, *Control*, *Setup*, and *Password*.

- Press Menu button to enter Programming Mode then press the Up arrow button to scroll main menu.
- Press Menu, at any time, to exit and return to Run Mode. Changes made to settings prior to pressing Enter are not saved.
- Changes to the settings are saved to memory only after pressing Enter.
- The display moves to the next menu every time a setting is accepted by pressing Enter.

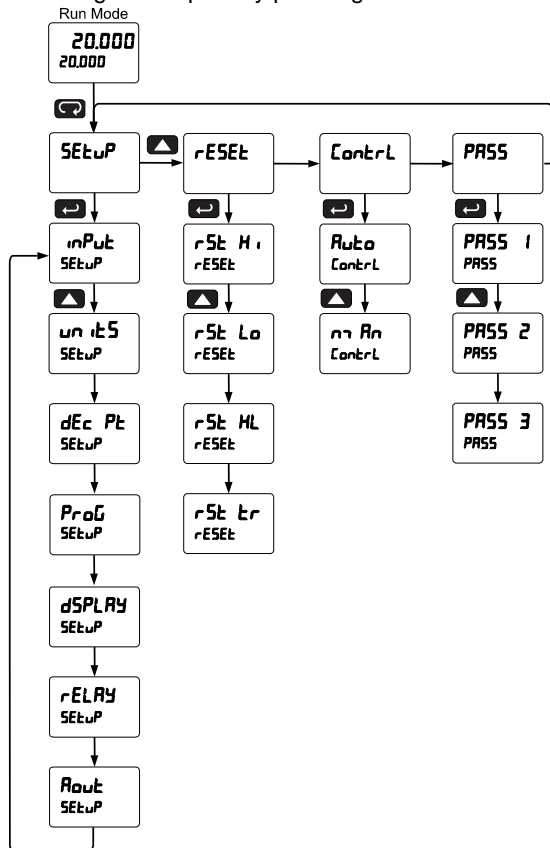

Setting Numeric Values

The numeric values are set using the Right and Up arrow buttons. Press Right arrow to select next digit and Up arrow to increment digit value. The digit being changed is displayed brighter than the rest. Press and hold Up to auto-increment the display value. If negative numbers are allowed, the first digit position will include a negative symbol (-) after the 9.

Press the Enter button, at any time, to accept a setting or Menu button to exit without saving changes.

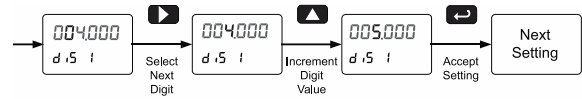

Setting Up the Meter (SEtUP)

The Setup menu is used to select:

1. Input signal the meter will accept for channel A and channel B
2. Units for A, B, and C
3. Decimal point position for A, B, and C
4. Program the meter using the Scale or Calibrate functions
5. Display parameter and intensity
6. Relay assignment and operation
7. 4-20 mA analog output scaling

Press the Menu button to exit at any time.

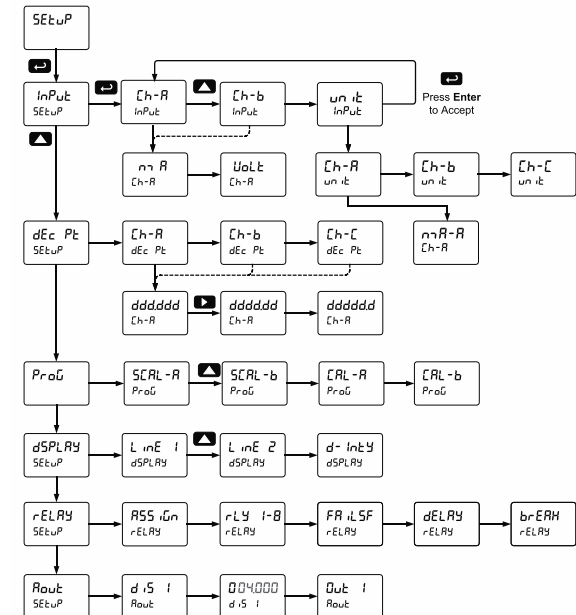

Setting the Input Signal (Input)

Enter the *Input* menu to set up the meter to display current (mA) or voltage (VDC) inputs for channel A and channel B.

The current input is capable of accepting any signal from 0 to 20 mA. Select current input to accept 0-20 mA or 4-20 mA signals.

The voltage input is capable of accepting any signal from -10 to +10 VDC. Select voltage input to accept 0-5, 1-5, 0-10, or ±10 VDC signals.

Channel C is the Math Function calculation, which is set up in the Advanced Features menu.

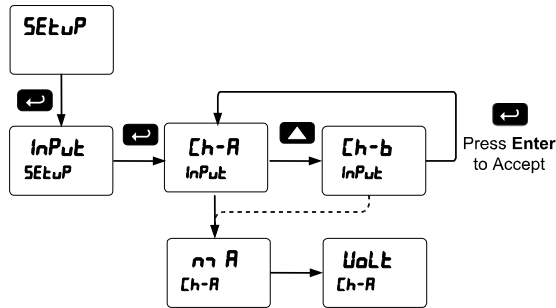

Setting the Display Units or Custom Tags (Units)

Enter the display unit or custom tag that will be displayed if alternating process input and units is selected in the *Units* menu, or *Units* is selected as the lower display parameter. See the *Setting the Display Parameter & Intensity (dSPLY)* flow chart on page 25 to access the display menu to show the unit or tag on display line 2. The engineering units or custom legends can be set using the following 7-segment character set:

Display	Character
0	0
1	1
2	2
3	3
4	4
5	5
6	6
7	7
8	8
9	9
A	A
b	b
C	C
c	c
d	d
E	E
F	F
G	G
g	g
H	H
h	h
I	I
i	i
J	J

Display	Character
K	K
L	L
m	m
n	n
O	O
o	o
P	P
q	q
r	r
S	S
t	t
u	u
V	V
w	w
X	X
Y	Y
Z	Z
.	.
/	/
]]
[[
=	=
°	Degree(<)
	Space

Notes:

Degree symbol represented by (<) if programming with MeterView Pro.

The letters “m” and “w” use two 7-segment LEDs each; when selected the characters to the right are shifted one position.

Press and hold up arrow to auto-scroll the characters in the display.

Setting the Decimal Point (dEc Pt)

The decimal point may be set with up to five decimal places or with no decimal point at all. Pressing the Right arrow moves the decimal point one place to the right until no decimal point is displayed, and then it moves to the leftmost position. There are three decimal points to set up for three channels: Ch-A, Ch-B, and Ch-C. After the decimal points are set up, the meter moves to the *Program* menu.

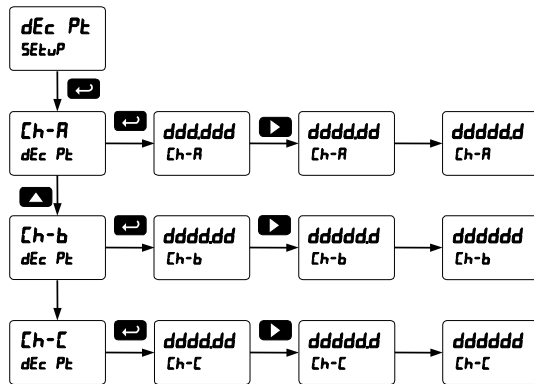

Programming the Meter (PrOG)

The meter may either be scaled (SCAL E) without applying an input or calibrated (CAL) by applying an input. The meter comes factory calibrated to NIST standards, so for initial setup, it is recommended to use the (SCAL E) function. The Program menu contains the Scale (SCAL E) and the Calibrate (CAL) menus. Process inputs may be scaled or calibrated to any display within the range of the meter. *Note: The Scale and Calibrate functions are exclusive of each other. The meter uses the last function programmed. Only one of these methods can be employed at a time. The Scale and Calibrate functions can use up to 32 points (default is 2). The number of points should be set in the Advanced Menu prior to scaling and calibration of the meter. See Multi-Point Linearization (LnERr) on page 38 for details.*

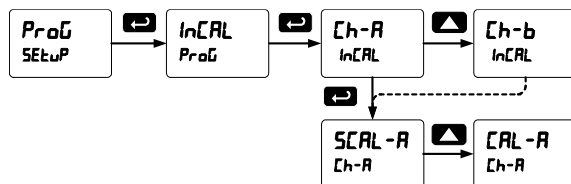

Multi-Point Linearization (LnERr)

The process inputs may be calibrated or scaled to any display value within the range of the meter. The meter is set up at the factory for 2-point linear calibration. Up to 32 linearization points may be selected. See *Multi-Point Linearization (LnERr)* on page 38 for details.

Scaling the Meter (SCAL E)

The process inputs (4-20 mA, ±10 VDC) can be scaled to display the process variables in engineering units. A signal source is not needed to scale the meter; simply program the inputs and corresponding display values.

Scaling the Meter for Channel A (SCAL -A)

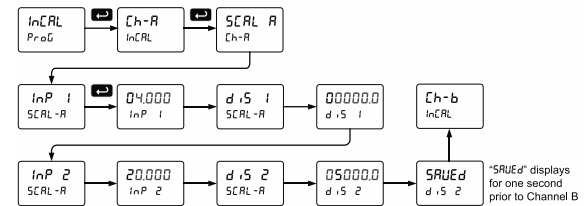

Scaling the Meter for Channel B (SCAL -b)

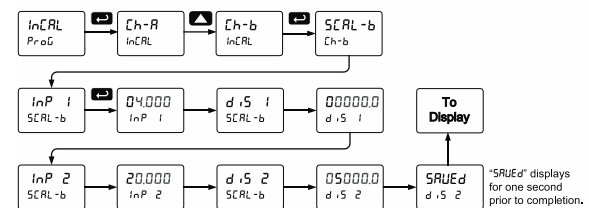

For instructions on how to program numeric values see *Setting Numeric Values*, page 21.

Error Message (Error)

An error message indicates that the calibration or scaling process was not successful. After the error message is displayed, the meter reverts to input 2 during calibration or scaling and to input 1 during internal calibration, allowing the appropriate input signal to be applied or programmed. The error message might be caused by any of the following conditions:

1. Input signal is not connected to the proper terminals or it is connected backwards.
2. Wrong signal selection in *Setup* menu.
3. Minimum input span requirements not maintained.
4. Input 1 signal inadvertently applied to calibrate input 2.

Minimum Input Span

The minimum input span is the minimum difference between input 1 and input 2 signals required to complete the calibration or scaling of the meter.

Input Range	Input 1 & Input 2 Span
4-20 mA	0.15 mA
±10 VDC	0.10 VDC

Calibrating the Meter with External Source (EAL)

Note: To scale the meter without a signal source, refer to *Scaling the Meter (SEALE)* on page 23.

The meter can be calibrated to display the process variable in engineering units by applying the appropriate input signal and following the calibration procedure.

The use of a calibrated signal source is strongly recommended to calibrate the meter.

Warm up the meter for at least 15 minutes before performing calibration to ensure specified accuracy.

Calibrating the Meter for Channel A (EAL-A)

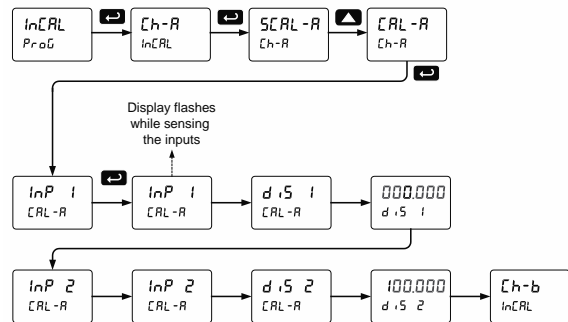

Calibrating the Meter for Channel B (EAL-b)

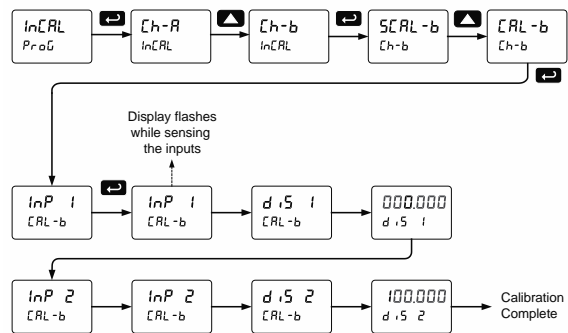

Setting the Display Parameter & Intensity (dSPLY)

Display line 1 can be programmed to display:

1. Process value Ch-A
2. Process value Ch-B
3. Process value Ch-C
4. Toggle between Ch-A & Ch-B, Ch-A & Ch-C, Ch-B & Ch-C, and Ch-A, Ch-B, & Ch-C
5. Relay set points
6. Max & min values for each channel
7. Toggle between Channel & units
8. Channel gross value (no tare) or toggle net (tare) and gross values
9. Modbus input

Display line 2 can be programmed to display:

1. Process value Ch-A
2. Process value Ch-B
3. Process value Ch-C
4. Toggle between Ch-A & Ch-B, Ch-A & Ch-C, Ch-B & Ch-C, and Ch-A, Ch-B, & Ch-C
5. Relay set points
6. Max & min values for each channel
7. Toggle between Channel & units
8. Channel gross value (no tare) or toggle net (tare) and gross values
9. Modbus input
10. Off (no display)
11. Engineering units or custom legends

After setting up the input and display, press the Menu button to exit programming and skip the rest of the setup menu.

The displays can be set up to read channels A, B, or C, toggle between A & B, B & C, A & C, A & B & C, toggle between channels A, B, or C & units, the max/min of any of the channels, including the math channel (C), set points, gross (without tare) or net (with tare) & gross values of channel A or B, or the Modbus input. In addition to the parameters available on the Upper display, the Lower display can display Engineering units or it could be turned off.

Display Intensity (d-IntY)

The meter has eight display intensity levels to give the best performance under various lighting conditions. Select intensity 8 for outdoor applications. The default intensity is 6.

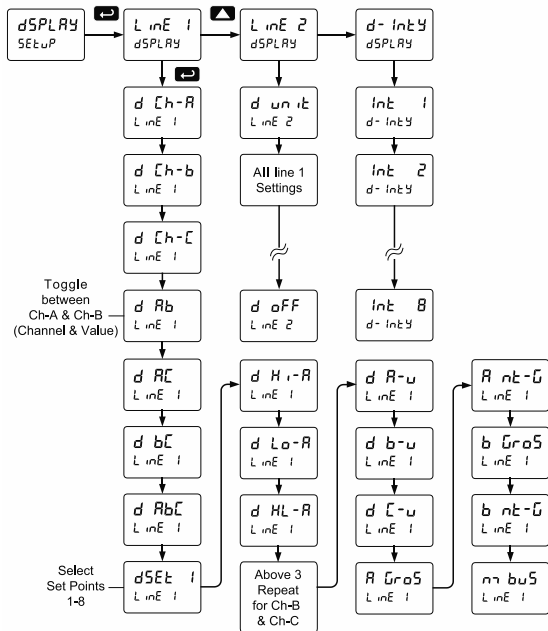

Setting the Relay Operation (rELAY)

This menu is used to set up the assignment and operation of the relays.

CAUTION

- During setup, the relays do not follow the input and they will remain in the state found prior to entering the Relay menu.

- Relay assignment
 - Channel A
 - Channel B
 - Channel C (Math channel)
 - Modbus
- Relay action
 - Automatic reset only (non-latching)
 - Automatic + manual reset at any time (non-latching)
 - Latching (manual reset only)
 - Latching with Clear (manual reset only after alarm condition has cleared)
 - Pump alternation control (automatic reset only)
 - Sampling (the relay is activated for a user-specified time)
 - Off (relay state controlled by Interlock feature)
- Set point
- Reset point
- Fail-safe operation
 - On (enabled)
 - Off (disabled)
- Time delay
 - On delay (0-999.9 seconds)
 - Off delay (0-999.9 seconds)
- Relay action for loss (break) of 4-20 mA input (ignore, on, off)

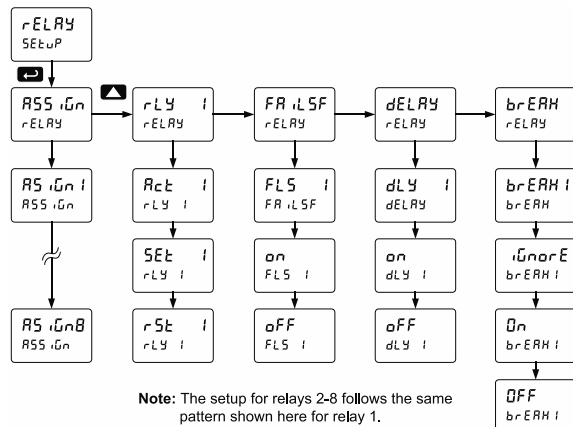

Setting the Relay Assignment (ASSIGN)

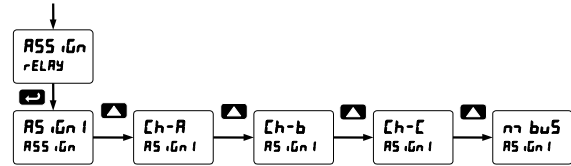

Setting the Relay Action

Operation of the relays is programmed in the *Action* menu. The relays may be set up for any of the following modes of operation:

- Automatic reset (non-latching)
- Automatic + manual reset at any time (non-latching)
- Latching (manual reset only, at any time)
- Latching with Clear (manual reset only after alarm condition has cleared)
- Pump alternation control (automatic reset only)
- Sampling (the relay is activated for a user-specified time)
- Off (relay state controlled by Interlock feature)

The following graphic shows relay 1 action setup; relay 2-8 are set up in a similar fashion.

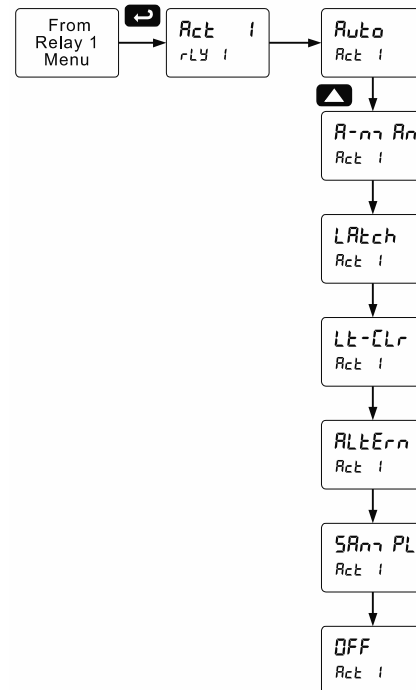

Programming Set and Reset Points

High alarm indication: program set point above reset point.

Low alarm indication: program set point below reset point.

The deadband is determined by the difference between set and reset points. Minimum deadband is one display count. If the set and reset points are programmed with the same value, the relay will reset one count below the set point.

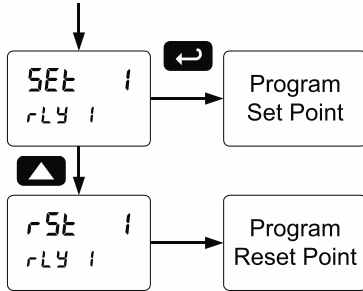

Note: Changes are not saved until the reset point has been accepted.

Setting Fail-Safe Operation

In fail-safe mode of operation, the relay coil is energized when the process variable is within safe limits and the relay coil is de-energized when the alarm condition exists. The fail-safe operation is set independently for each relay. Select **on** to enable or select **off** to disable fail-safe operation.

Programming Time Delay

The *On* and *Off* time delays may be programmed for each relay between 0 and 999.9 seconds. The relays will transfer only after the condition has been maintained for the corresponding time delay.

The *On* time delay is associated with the set point.

The *Off* time delay is associated with the reset point.

Relay Action for Loss of 4-20 mA Input (Loop Break)

The loop break feature is associated with the 4-20 mA input. Each relay may be programmed to go to one of the following conditions when the meter detects the loss of the input signal (i.e. < 0.005 mA):

1. Turn *On* (Go to alarm condition)
2. Turn *Off* (Go to non-alarm condition)
3. Ignore (Processed as a low signal condition)

Note: This is not a true loop break condition; if the signal drops below 0.005 mA, it is interpreted as a "loop break" condition.

The following graph shows the loop break relay operation for a high alarm relay.

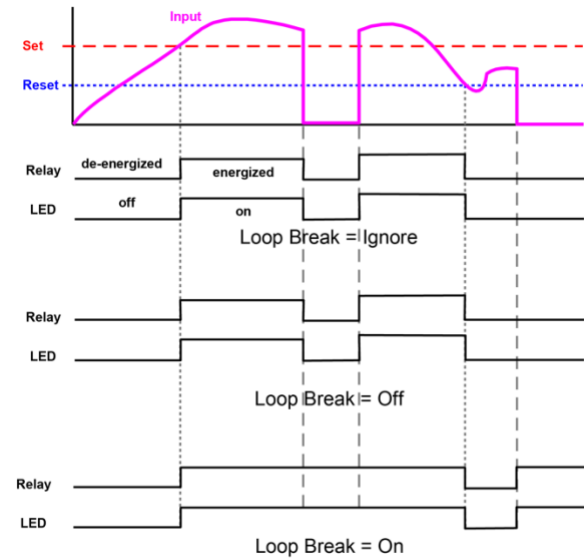

Relay and Alarm Operation Diagrams

The following graphs illustrate the operation of the relays, status LEDs, and ACK button.

High Alarm Operation (Set > Reset)

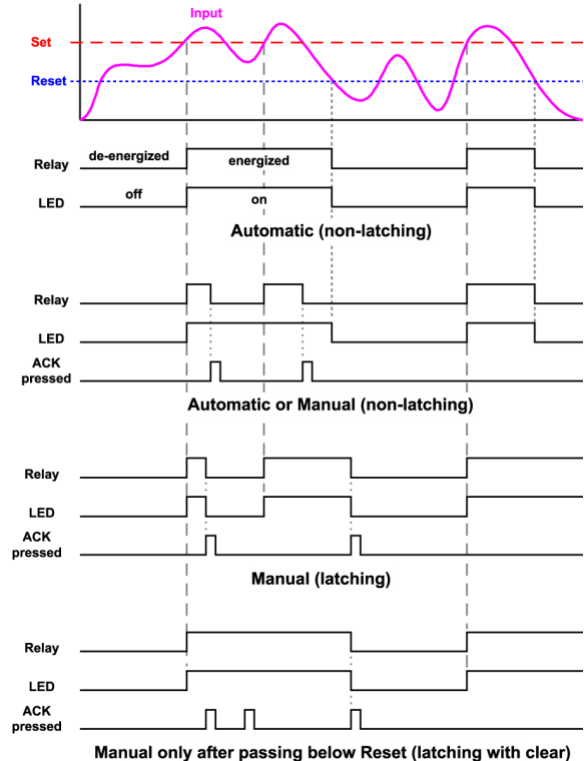

For Manual reset mode, ACK can be pressed anytime to turn "off" relay. To detect a new alarm condition, the signal must go below the set point, and then go above it.

Low Alarm Operation (Set < Reset)

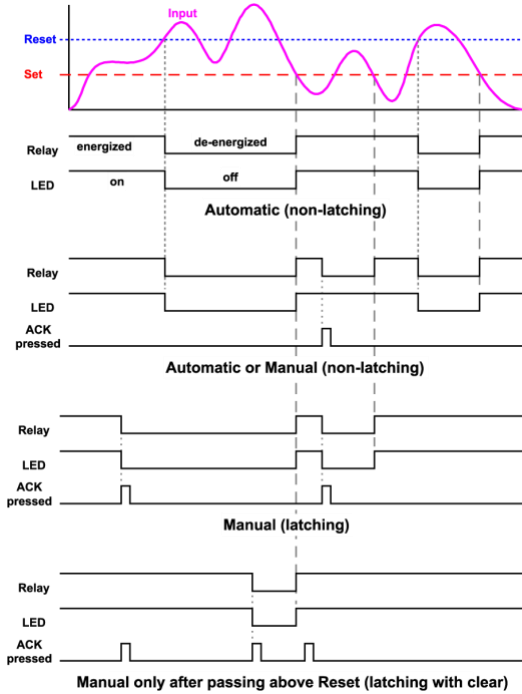

For Manual reset mode, ACK can be pressed anytime to turn "off" relay. For relay to turn back "on", signal must go above set point and then go below it.

Low Alarm with Fail-Safe Operation (Set < Reset)

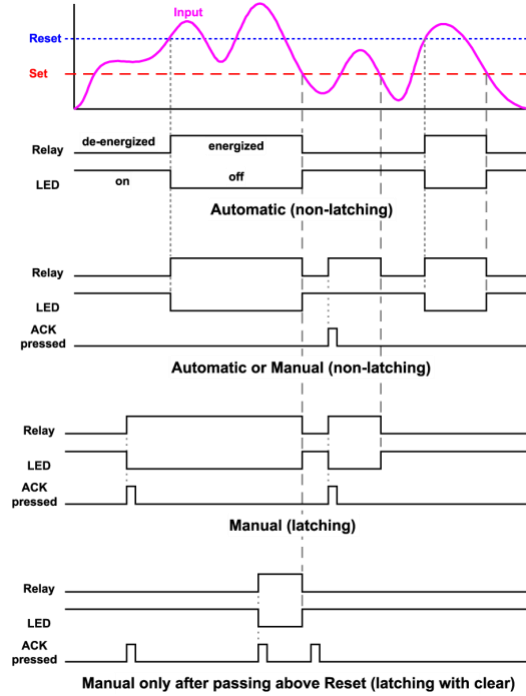

Note: Relay coil is energized in non-alarm condition. In case of power failure, relay will go to alarm state.

High Alarm with Fail-Safe Operation (Set > Reset)

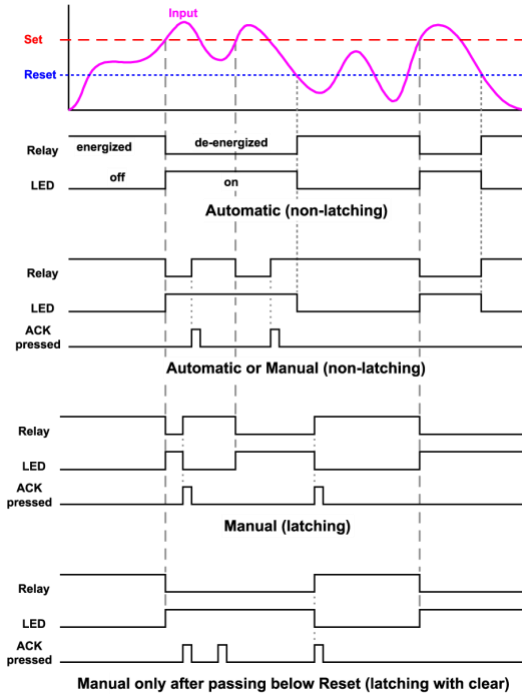

Note: Relay coil is energized in non-alarm condition. In case of power failure, relay will go to alarm state.

Time Delay Operation

The following graphs show the operation of the time delay function.

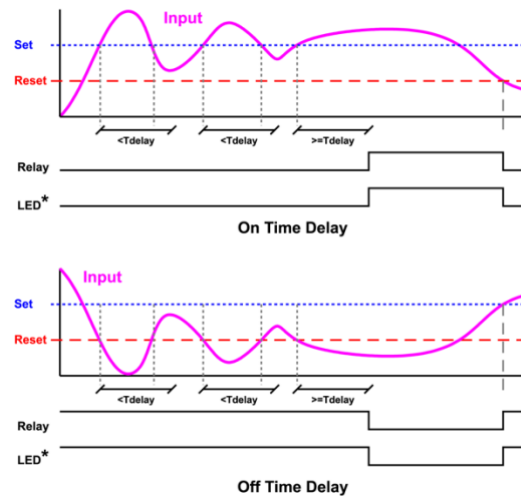

When the signal crosses the set point, the On time delay timer starts and the relay trips when the time delay has elapsed. If the signal drops below the set point (high alarm) before the time delay has elapsed, the On time delay timer resets and the relay does not change state. The same principle applies to the Off time delay.

Note: If "Automatic or Manual (R-nRn)" reset mode is selected, the LED follows the reset point and not the relay state when the relay is acknowledged.

Pump Alternation Control Operation

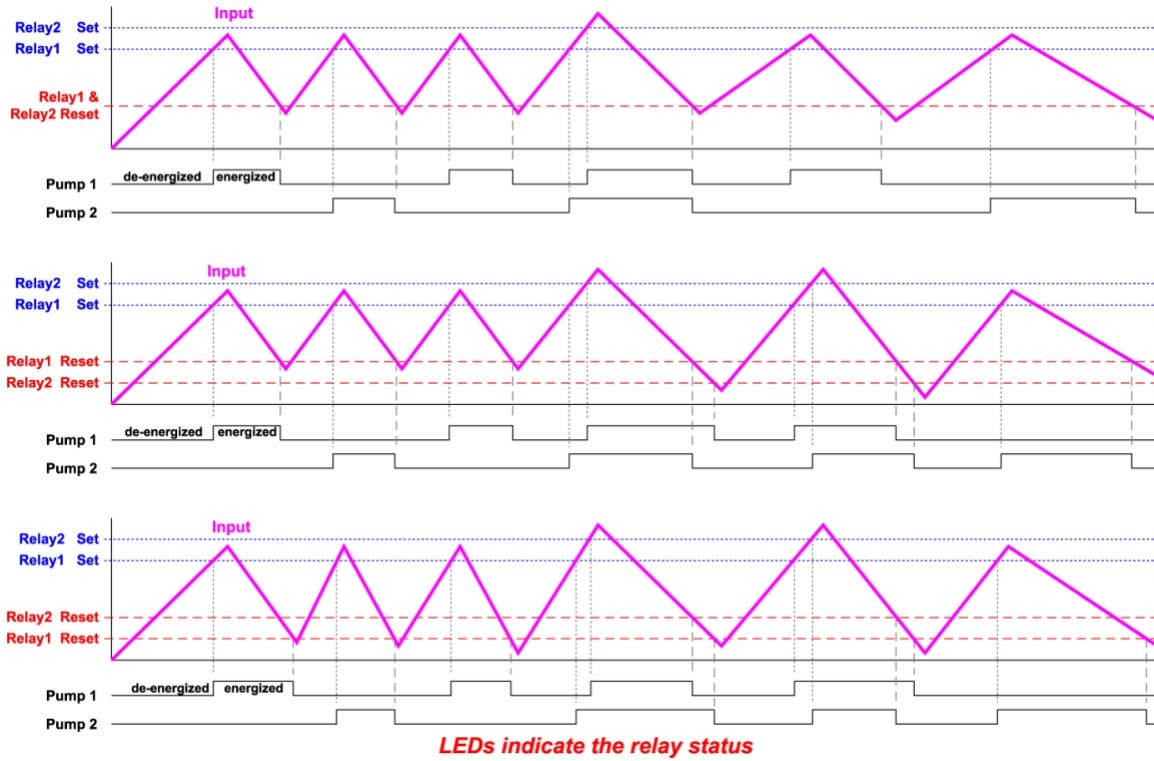

Relay Sampling Operation

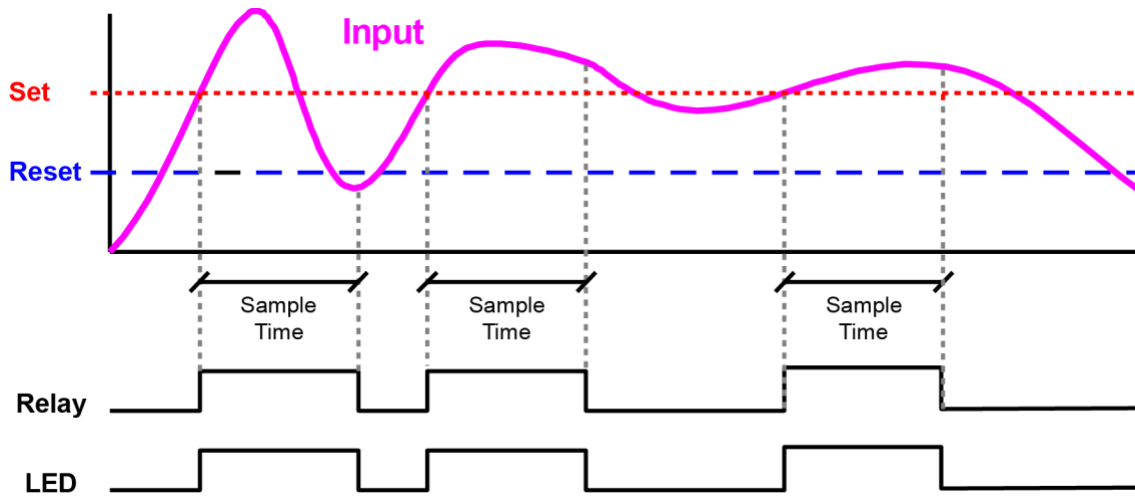

When the signal crosses the set point, the relay trips and the sample time starts. After the sample time has elapsed, the relay resets. The cycle repeats every time the set point is crossed, going up for high alarms and going down for low alarms.

The sample time can be programmed between 0.1 and 5999.9 seconds.

Relay Operation Details

Overview

The relay capabilities of the meter expand its usefulness beyond simple indication to provide users with alarm and control functions. These capabilities include front panel alarm status LEDs as well as either 2 or 4 optional internal relays and/or 4 external relays expansion module. Typical applications include high or low temperature, level, pressure or flow alarms, control applications such as simple on/off pump control, and pump alternation control for up to 8 pumps. There are four basic ways the relays can be used:

1. High or Low Alarms with Latching or Non-Latching Relays
2. Simple On/Off Control with 100% Adjustable Deadband
3. Sampling (Based on Time)
4. Pump Alternation Control for up to 8 Pumps

Relays Auto Initialization

When power is applied to the meter, the front panel LEDs and alarm relays will reflect the state of the input to the meter. The following table indicates how the alarm LEDs and relays will react on power-up based on the set and reset points:

Alarm #	HI or LO Alarm	Set Point	Reset Point	Power-Up Reading	Relay & LED
1	HI	1000	500	499	Off
2	LO	700	900	499	On
3	LO	250	400	499	Off
4	HI	450	200	499	On

Fail-Safe Operation

The following table indicates how the relays behave based on the fail-safe selection for each relay:

Fail-Safe Selection	Non-Alarm State		Alarm State		Power Failure
	NO	NC	NO	NC	
Off	Open	Closed	Closed	Open	Relays go to non-alarm state
On	Closed	Open	Open	Closed	Relays go to alarm state

Note: NO = Normally Open, NC = Normally Closed. This refers to the condition of the relay contacts when the power to the meter is off.

Front Panel LEDs

The LEDs on the front panel provide status indication for the following:

LED	Status
1	Alarm 1
2	Alarm 2
3	Alarm 3
4	Alarm 4

LED	Status
5	Alarm 5
6	Alarm 6
7	Alarm 7
8	Alarm 8

The meter is supplied with four alarm points that include front panel LEDs to indicate alarm conditions. This standard feature is particularly useful for alarm applications that require visual-only indication. The LEDs are controlled by the set and reset points programmed by the user. When the display reaches a set point for a high or low alarm, the corresponding alarm LED will turn on. When the display returns to the reset point the LED will go off. The front panel LEDs responds differently for latching and non-latching relays.

For non-latching relays, the LED is always off during normal condition and always on during alarm condition, regardless of the state of the relay (e.g. Relay acknowledged after alarm condition).

For latching relays, the alarm LEDs reflects the status of the relays, regardless of the alarm condition. The following tables illustrate how the alarm LEDs function in relation to the relays and the acknowledge button (Default: F3 key assigned to ACK).

Latching and Non-Latching Relay Operation

The relays can be set up for latching (manual reset) or non-latching (automatic reset) operation.

Relay terminology for following tables	
Terminology	Relay Condition
On	Alarm (Tripped)
Off	Normal (Reset)
Ack	Acknowledged

The On and Off terminology does not refer to the status of the relay's coil, which depends on the fail-safe mode selected.

WARNING

- In latching relay mode, if Fail-Safe is off, latched relays will reset (unlatch) when power is cycled.

Non-Latching Relay (ᄁᄁᄁ)

In this application, the meter is set up for automatic reset (non-latching relay). Acknowledging the alarm while it is still present has no effect on either the LED or the relay. When the alarm finally goes away, the relay automatically resets and the LED also goes off.

Automatic reset only		
Condition	LED	Relay
Normal	Off	Off
Alarm	On	On
Ack (No effect)	On	On
Normal	Off	Off

Non-Latching Relay with Manual Reset (ᄁᄁᄁᄁ)

In this application, the meter is set up for automatic and manual reset at any time (non-latching relay). The LED and the relay automatically reset when the meter returns to the normal condition.

In addition, the relay can be manually reset while the alarm condition still exists, but the LED will stay on until the meter returns to the normal condition.

Automatic + manual reset at any time		
Condition	LED	Relay
Normal	Off	Off
Alarm	On	On
Normal	Off	Off
Next Alarm	On	On
Ack	On	Off
Normal	Off	Off

Latching Relay (ᄁᄁᄁᄁ)

In this application, the meter is set up for manual reset at any time. Acknowledging the alarm even if the alarm condition is still present resets the relay and turns off the LED.

Manual reset any time		
Condition	LED	Relay
Normal	Off	Off
Alarm	On	On
Ack	Off	Off

Latching Relay with Clear (ᄁᄁ-ᄁᄁᄁ)

In this application, the meter is set up for manual reset only after the signal passes the reset point (alarm condition has cleared). Acknowledging the alarm while it is still present has no effect on either the LED or the relay. When the alarm is acknowledged after it returns to the normal state, the LED and the relay go off. Notice that the LED remains on, even after the meter returns to the normal condition. This is because, for latching relays, the alarm LED reflects the status of the relay, regardless of the alarm condition.

Manual reset only after alarm condition has cleared		
Condition	LED	Relay
Normal	Off	Off
Alarm	On	On
Ack (No effect)	On	On
Normal	On	On
Ack	Off	Off

Acknowledging Relays

There are three ways to acknowledge relays programmed for manual reset:

1. Via the programmable front panel function keys F1-F3 (Example: F3 assigned to ACK).

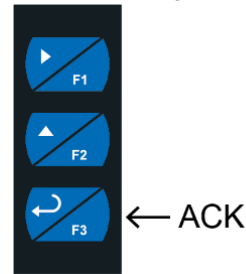

2. Remotely via a normally open pushbutton wired to the F4 terminal at the rear of the instrument.

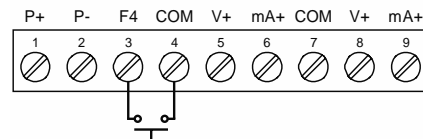

3. One of the digital inputs and the +5 V terminals on the digital I/O expansion module.

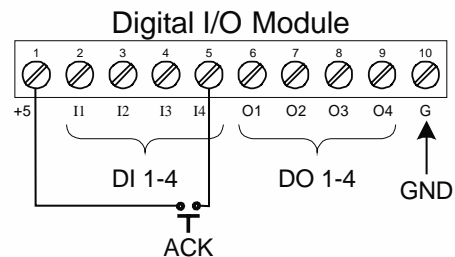

When the ACK button or the assigned digital input is closed, all relays programmed for manual reset are acknowledged.

Pump Alternation Control Applications (RLtErn)

For pump control applications where two or more similar pumps are used to control the level of a tank or a well, it is desirable to have all the pumps operate alternately. This prevents excessive wear and overheating of one pump over the lack of use of the other pumps.

Up to 8 relays can be set up to alternate every time an on/off pump cycle is completed. The set points and reset points can be programmed, so that the first pump on is the first pump off.

Application #1: Pump Alternation Using Relays 1 & 2

1. Relays 1 and 2 are set up for pump alternation.
2. Relays 3 and 4 are set up for low and high alarm indication.

Set and Reset Point Programming			
Relay	Set Point	Reset Point	Function
1	30.000	10.000	Controls pump #1
2	35.000	5.000	Controls pump #2
3	4.000	9.000	Controls low alarm
4	40.000	29.000	Controls high alarm

Pump Alternation Operation

1. Pump #1 turns on when level reaches 30.000, when level drops below 10.000 pump #1 turns off.
2. The next time level reaches 30.000, pump #2 turns on, when level drops below 10.000, pump #2 turns off.
3. If the level doesn't reach 35.000 pump #1 and pump #2 will be operating alternately.
4. If pump #1 cannot keep the level below 35.000 pump #2 will turn on at 35.000, then as the level drops to 10.000 pump #1 turns off, pump #2 is still running and shuts off below 5.000.
5. Notice that with the set and reset points of pump #2 outside the range of pump #1, the first pump on is the first pump to go off. This is true for up to 8 alternating pumps, if setup accordingly.
6. Relay #3 will go into alarm if the level drops below 4.000 and relay #4 will go into alarm if the level exceeds 40.000.
7. Adding the 4 external relays expansion module allows using the 4 SPDT internal relays for pump alternation and the 4 SPST external relays for high, high-high, low, and low-low alarm indication.

Setting Up the Interlock Relay (Force On) Feature

Relays 1-4 can be set up as interlock relays. To set up the relays for the interlock feature:

1. Access the Setup – Relay – Action menu and set the action to off.

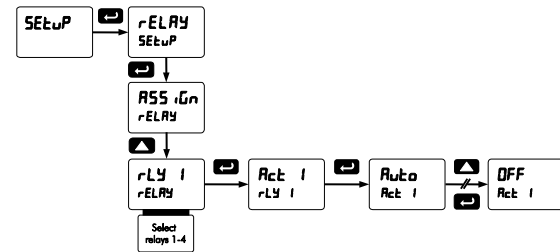

2. In the Advanced features – User menu program any of the digital inputs to Force On any of the internal relays (1-4).

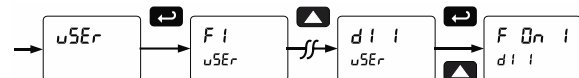

3. Connect a switch or dry contact between the +5V terminal and the corresponding digital input (dl-1 to dl-4) terminal.

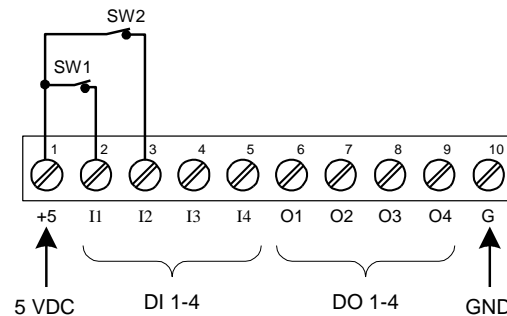

Interlock Relay Operation Example

Relays 1 & 2 are configured to energize (their front panel LEDs are steady on) when SW1 & SW2 switches (above) are closed. If the contacts to these digital inputs are opened, the corresponding front panel LEDs flash, indicating this condition. The processes being controlled by the interlock relay will stop, and will re-start only after the interlock relay is re-activated by the digital inputs (switches).

Note: If multiple digital inputs are assigned to the same relay, then the corresponding logic is (AND) – i.e. both switches must be closed to trip the relay.

Scaling the 4-20 mA Analog Output (Rout)

The 4-20 mA analog outputs can be scaled to provide a 4-20 mA signal for any display range selected. To select the channel and source assignments the analog outputs are assigned to, see *Analog Output Source* on page 39.

No equipment is needed to scale the analog outputs; simply program the display values to the corresponding mA output signal.

The *Analog Output* menu is used to program the 4-20 mA outputs based on display values.

For further details, see *Setting Numeric Values*, page 21, *Relay Action for Loss of 4-20 mA Input (Loop Break)*, page 27.

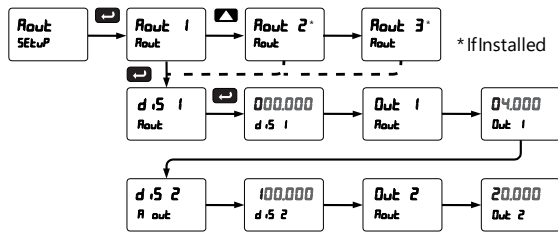

Reset Menu (rESEt)

The *Reset* menu is used to reset the maximum or minimum reading (peak or valley) reached by the process; both may be reset at the same time by selecting "reset high & low" (r5t HL). The tare value used to zero the display may be reset by selecting "reset tare" (r5t tr).

Manual Control Menu (Contrl)

The *Manual Control* menu is used to control the 4-20 mA analog output and the relays manually, ignoring the input. Each relay and analog output can be programmed independently for manual control. Selecting automatic control sets all relays and analog output for automatic operation.

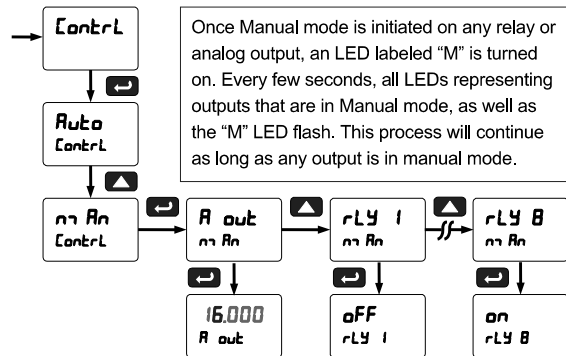

Setting Up the Password (PASS)

The *Password* menu is used for programming three levels of security to prevent unauthorized changes to the programmed parameter settings.

- Pass 1: Allows use of function keys and digital inputs
- Pass 2: Allows use of function keys, digital inputs and editing set/reset points
- Pass 3: Restricts all programming, function keys, and digital inputs.

Protecting or Locking the Meter

Enter the *Password* menu and program a six-digit password.

For instructions on how to program numeric values see *Setting Numeric Values*, page 21.

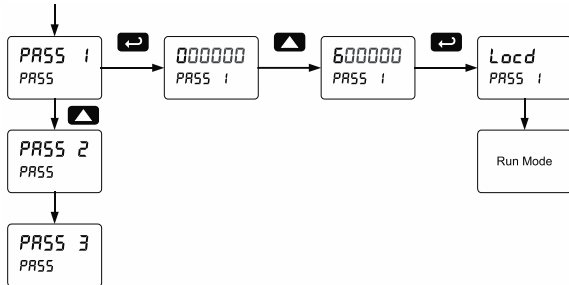

Making Changes to a Password Protected Meter

If the meter is password protected, the meter will display the message *Locd* (*Locked*) when the Menu button is pressed. Press the Enter button while the message is being displayed and enter the correct password to gain access to the menu. After exiting the programming mode, the meter returns to its password protected condition.

Disabling Password Protection

To disable the password protection, access the *Password* menu and enter the correct password twice, as shown below. The meter is now unprotected until a new password is entered.

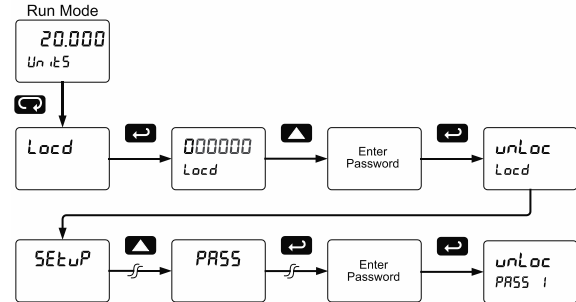

If the correct six-digit password is entered, the meter displays the message *unLoc* (*Unlocked*) and the protection is disabled until a new password is programmed.

If the password entered is incorrect, the meter displays the message *Locd* (*Locked*) for about two seconds, and then it returns to Run Mode. To try again, press Enter while the *Locked* message is displayed.

Did you forget the password?

The password may be disabled by entering a master password once. If you are authorized to make changes, enter the master password 508655 to unlock the meter.

Advanced Features Menu

To simplify the setup process, functions not needed for most applications are located in the *Advanced Features* menu.

Press and hold the Menu button for three seconds to access the advanced features of the meter.

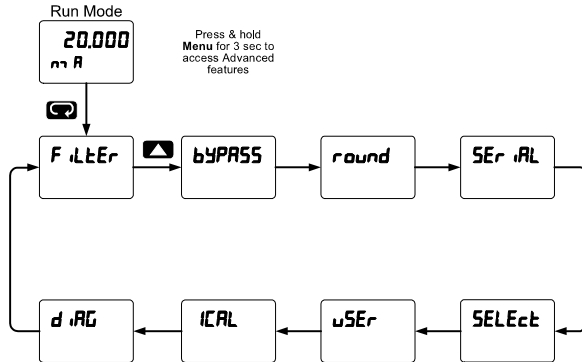

Advanced Features Menu & Display Messages

The following table shows the functions and messages of the *Advanced Features* menu in the order they appear in the menu.

Advanced Features Menu & Display Messages		
Display	Parameter	Action/Setting
F .iLkEr	Filter	Set noise filter value
Ch-A	Channel A	Set filter value for channel A
Ch-B	Channel B	Set filter value for channel B
bYPASS	Bypass	Set filter bypass value
Ch-A	Channel A	Set filter bypass value for channel A
Ch-B	Channel B	Set filter bypass value for channel B
rOund	Round	Set the rounding value for display variables
SERIAL	Serial	Set serial communication parameters
SlAVE ID	Slave ID	Set slave ID or meter address
bAud	Baud rate	Select baud rate
tr dLY	Transmit delay	Set transmit delay for serial communication
PRr .tY	Parity	Select parity Even, Odd, or None with 1 or 2 stop bits
t-bYt	Time byte	Set byte-to-byte timeout
SElEcT	Select	Enter the Select menu (function, cutoff, out)
FuncTn	Input signal conditioning	Select linear, square root, programmable exponent, or round horizontal tank
Ch-A	Channel A	Select menu for channel A

Advanced Features Menu & Display Messages		
Display	Parameter	Action/Setting
Ch-B	Channel B	Select menu for channel B
LinER	Linear	Set meter for linear function and select number of linearization points
no Pts	Number of points	Set the number of linearization points (default: 2)
SqURt	Square root	Set meter for square root extraction
PrOg E	Programmable exponent	Set meter for programmable exponent and enter exponent value
rht	Round horizontal tank	Set meter for round horizontal tank volume calculation
LEnGth	Length	Enter the tank's length in inches
d .mtr	Diameter	Enter the tank's diameter in inches
math	Math	Enter the setup menu for channel C math functions
Sum	Sum	Channel C = (A+B+P)*F
d .F	Difference	Channel C = (A-B+P)*F
d .FRbS	Absolute difference	Channel C = ((Absolute value of (A-B))+P)*F
Avg	Average	Channel C = (((A+B)/2)+P)*F
mult	Multiplication	Channel C = ((A*B)+P)*F
d .v dE	Divide	Channel C = ((A/B)+P)*F
H .-Rb	Max of A or B	C = ((High value of channel A or B)+P)*F
L .-Rb	Min of A or B	C = ((Low value of channel A or B)+P)*F
dr Rv	Draw	Channel C = ((A/B)-1)*F
w .Rv	Weighted avg.	Channel C = ((B-A)*F)+A
rRt .v	Ratio	Channel C = (A/B)*F
rRt .v2	Ratio 2	C = ((B-A)/A)+P)*F
ConcEn	Concentration	Channel C = (A/(A+B))*F
ConSt	Constant	Constant used in channel C math
AdDEr	Adder	Addition constant used in channel C math calculations (P)
FRcTOR	Factor	Multiplication constant used in channel C math calculations (F)
LoFF	Cutoff	Set low-flow cutoff
Ch-A	Channel A	Set low-flow cutoff for Channel A
Ch-B	Channel B	Set low-flow cutoff for Channel B

Advanced Features Menu & Display Messages		
Display	Parameter	Action/Setting
RoutPr	Analog output programming	Program analog output parameters
Rout 1	Analog output 1	Program analog output 1 (*1-3) parameters
Source	Source	Select source for the 4-20 mA output
brERR	Loop break	Set relay condition if loop break detected
Overr	Overrange	Program mA output for display overrange
Underr	Underrange	Program mA output for display underrange
max	Maximum	Program maximum mA output allowed
min	Minimum	Program minimum mA output allowed
Calib	Calibrate	Calibrate 4-20 mA output (internal reference source used for scaling the output)
4 mA	4 mA output	Enter mA output value read by milliamp meter with at least 0.001 mA resolution
20 mA	20 mA output	Enter mA output value read by milliamp meter with at least 0.001 mA resolution
User	User I/O	Assign function keys and digital I/O
F1	F1* function key	Assign F1 function key (*F1/F2/F3)
F4	F4 function	Assign F4 function (digital input)
d1	Digital input 1	Assign digital input 1 – 8, if expansion modules are connected
d0	Digital output 1	Assign digital output 1 – 8, if expansion modules are connected
ICAL	Internal calibration	Enter internal calibration (used for recalibrating the meter with a calibrated signal source)
Ch-A	Channel A	Perform calibration on channel A
Ch-b	Channel B	Perform calibration on channel B
CCAL	Current calibration	Calibrate 4-20 mA current input (internal reference source used for scaling the input)
CLo	Current low	Calibrate low current input (e.g. 4 mA)
CHi	Current high	Calibrate high current input (e.g. 20 mA)
VCAL	Voltage calibration	Calibrate voltage input

Advanced Features Menu & Display Messages		
Display	Parameter	Action/Setting
U Lo	Voltage low	Calibrate low voltage input (e.g. 0 V)
U Hi	Voltage high	Calibrate high voltage input (e.g. 10 V)
d.RG	Diagnostics	Display parameter settings
LED t	LED test	Test all LEDs
Info	Information	Display software and S/N information

Noise Filter (F ILtEr)

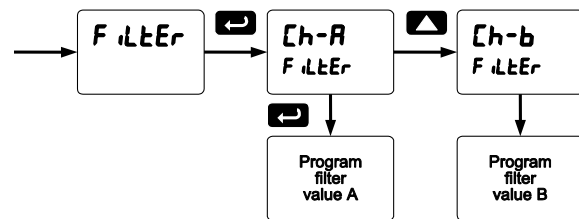

The noise filter is available for unusually noisy signals that cause an unstable process variable display. The noise filter averages the input signal over a certain period. The filter level determines the length of time over which the signal is averaged. The filter level can be set between 2 and 199. The higher the filter level, the longer the averaging time and so the longer it takes the display to settle to its final value. Setting the filter level to zero disables the filter function.

Noise Filter Bypass (bYPASS)

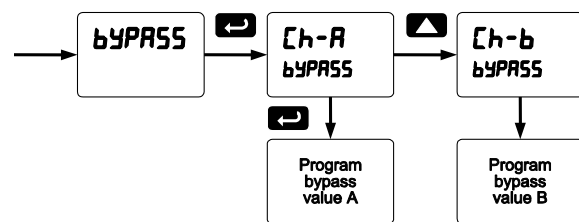

The noise filter bypass changes the behavior of the meter so that small variations in the signal are filtered out but large abrupt changes in the input signal are displayed immediately. The bypass value determines the minimum amount of signal change to be displayed immediately. All signal changes smaller than the bypass value are filtered or averaged by the meter. The noise filter bypass may be set between 0.1 and 99.9% of full scale.

Rounding Feature (round)

The rounding feature is used to give the user a steadier display with fluctuating signals. Rounding is used in addition to the filter function.

Rounding causes the display to round to the nearest value according to the rounding selected. See examples below:

Rounding Selection	Actual Value	Display Value	Actual Value	Display Value
1	12.022	12.022	12.023	12.023
5	12.022	12.020	12.023	12.025
10	12.024	12.020	12.025	12.030

Modbus RTU Serial Communications (SERIAL)

The meter is equipped with serial communications capability as a standard feature using Modbus RTU Serial Communication Protocol.

The meter may be connected to a PC for initial configuration via the onboard micro USB connection. For ongoing digital communications with a computer or other data terminal equipment, an RS-232, or RS-485 option is required; see *Ordering Information* on page 6 for details.

CAUTION

- **DO NOT** connect any equipment other than Precision Digital's expansion modules, cables, or meters to the RJ45 M LINK connector. Otherwise damage will occur to the equipment and the meter.

Note: More detailed instructions are provided with each optional serial communications adapter.

Note: Refer to the ProVu Modbus Register Tables located at www.predig.com for details.

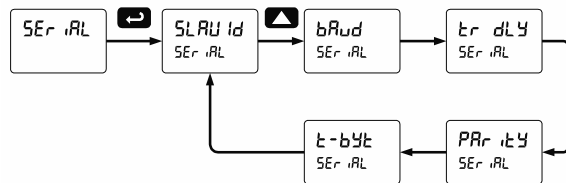

When using more than one meter in a multi-drop mode, each meter must be provided with its own unique address. The meter address (Slave ID) may be programmed between 1 and 247. The transmit delay may be set between 0 and 199 ms. The parity can be set to even, odd, or none with 1 or 2 stop bits. Changes made to the Serial menu are initialized after the MENU key is pressed or after navigating through the t-byte parameter.

Select Menu (SELEct)

The *Select* menu is used to select the input signal conditioning function applied to the inputs (linear, square root, programmable exponent, or round horizontal tank), math function for A & B, constants, low-flow cutoff, and analog output programming. Multi-point linearization is part of the linear function selection.

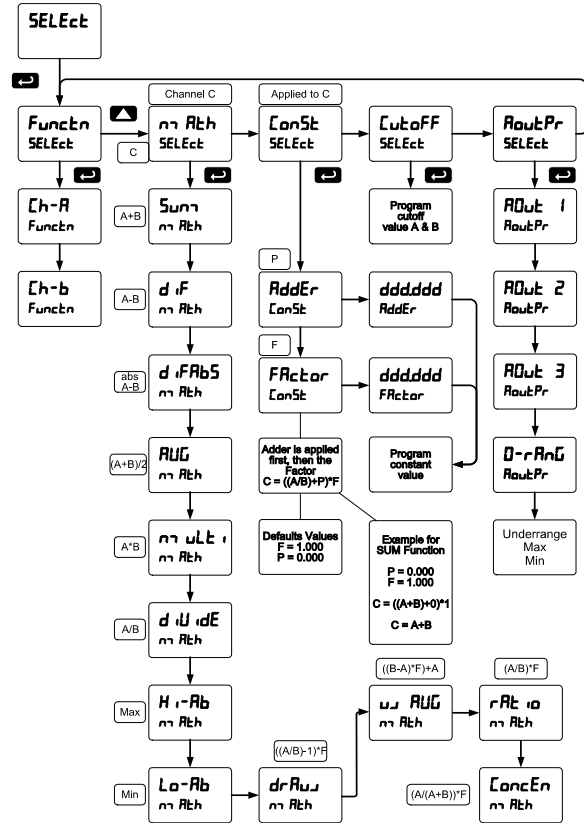

Input Signal Conditioning (Functn)

The *Function* menu is used to select the input-to-output transfer function applied to the input signal: linear, square root, programmable exponent, or round horizontal tank volume calculation. Multi-point linearization is part of the linear function selection. Meters are set up at the factory for linear function with 2-point linearization. The linear function provides a display that is linear with respect to the input signal.

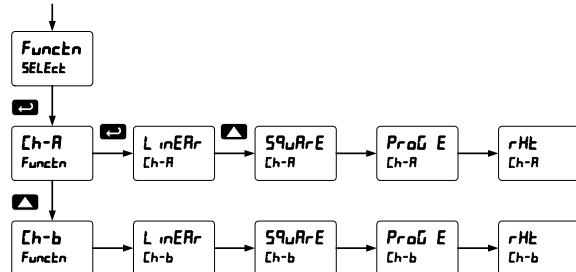

Square Root Linearization (SQUR E)

The square root function is used to calculate flow measured with a differential pressure transmitter. The flow rate is proportional to the square root of the differential pressure. Scale the meter so that the low input signal (e.g. 4 mA) is equal to zero flow and the high input signal (e.g. 20 mA) is equal to the maximum flow.

Programmable Exponent Linearization (PROG E)

The programmable exponent function is used to calculate open-channel flow measured with a level transmitter in weirs and flumes. The flow rate is proportional to the head height. Scale the meter so that the low input signal (e.g. 4 mA) is equal to zero flow and the high input signal (e.g. 20 mA) is equal to the maximum flow. This method works well for all weirs and flumes that have a simple exponent in the flow calculation formula. For weirs and flumes with complex exponents it is necessary to use a strapping table and the 32-point linearization of the meter.

Multi-Point Linearization (LINER)

Meters are set up at the factory for linear function with 2-point linearization. Up to 32 linearization points can be selected for each channel under the linear function. The multi-point linearization can be used to linearize the display for non-linear signals such as those from level transmitters used to measure volume in odd-shaped tanks or to convert level to flow using weirs and flumes with complex exponent.

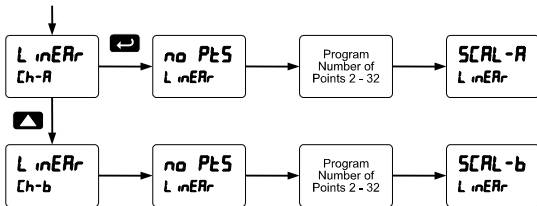

Round Horizontal Tank Linearization (RHLE)

This function is used to calculate volume in a round horizontal tank with flat ends. The volume is calculated based on the diameter and length of the tank. The tank's dimensions can be entered in inches or centimeters; the meter automatically calculates the volume in gallons or liters. After entering the dimensions, complete the scaling process with the display values calculated by the meter. The meter can be re-scaled to display the volume in any engineering unit without the need to re-enter the dimensions again.

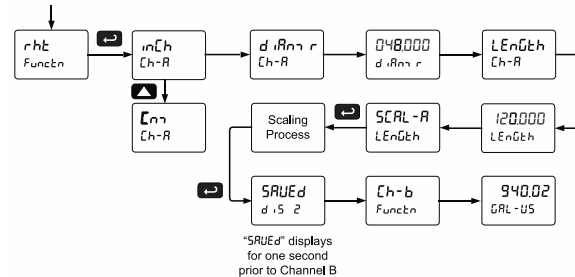

Note: After Scale is displayed continue pressing the Enter button until the meter completes the scaling of the input and display values.

Changing the Volume from Gallons to Liters

In the above graphic, entering the 48" for the diameter and 120" for the length of the round horizontal tank, the meter automatically calculates that the volume of the tank is 940.02 gallons.

1. Convert gallons to liters
1 US gallon = 3.7854 L
940.02 gal = 3558.4 L
2. Go to the Setup menu and change the decimal point to 1 decimal.
3. Go to the Program – Scale menu and press Enter until d, S 2 is shown on the Upper display.
4. Press Enter and change the display 2 value to 3558.4.
5. The meter is now displaying the volume in liters.

Note: The display can be scaled to display the volume in any engineering units.

Math Function (ጠገደክ)

The *Math* menu is used to select the math function that will determine the channel C value. These math functions are a combination of input channels A and B, and will display when channel C is selected in the *Display* menu.

The following math functions are available.

Name	Function	Setting
Addition	$(A+B+P)*F$	5ሀጠገ
Difference	$(A-B+P)*F$	ፈሳፍ
Absolute diff.	$((Abs(A-B))+P)*F$	ፈሳፍፅ
Average	$((A+B)/2+P)*F$	ጸሀህ
Multiplication	$((A*B)+P)*F$	ጠገፅፅፅ
Division	$((A/B)+P)*F$	ፈሳፍፅፅ
Max of A or B	$((AB-Hi)+P)*F$	ጸሳፅፅ
Min of A or B	$((AB-Lo)+P)*F$	ፈሳፅፅ
Draw	$((A/B)-1)*F$	ፈሳፅፅፅ
Weighted avg.	$((B-A)*F)+A$	ሀሀ ጸሀህ
Ratio	$(A/B)*F$	ጠገፅ ሳፅ
Ratio 2	$((B-A)/A+P)*F$	ጠገፅ ሳፅፅ
Concentration	$(A/(A+B))*F$	ፈሳፅፅፅ

Math Constants (ፈሳፅፅፅ)

The *Math Constants* menu is used to set the constants used in channel C math. The math functions include input channel A and B, as well as the adder constant P, and factor constant F.

The *Adder* constant (P) may be set from -99.999 to 999.999.

The *Factor* constant (F) may be set from 0.001 to 999.999.

The *Math Function* (ጠገደክ) chart above details the math functions that may be selected in the *Math Function* menu.

Low-Flow Cutoff (ፈሳፅፅፅ)

The low-flow cutoff feature allows the meter to be programmed so that the often-unsteady output from a differential pressure transmitter, at low flow rates, always displays zero on the meter.

The cutoff value may be programmed from 0 to 999999. The meter will display zero below the cutoff value. Programming the cutoff value to zero disables the cutoff feature.

Analog Output Programming (ጸሳፅፅፅ)

The *Analog Output Programming* menu is used to program the behavior of the 4-20 mA output. The following parameters and functions are programmed in this menu:

1. Source: Source for generating the 4-20 mA output
2. Overrange: Analog output value with display in overrange condition
3. Underrange: Analog output value with display in underrange condition
4. Break: Analog output value when loop break is detected
5. Max: Maximum analog output value allowed regardless of input
6. Min: Minimum analog output value allowed regardless of input
7. Calibrate: Calibrate the internal 4-20 mA source reference used to scale the 4-20 mA output

Analog Output Source

The analog output source can be based on either of the input channels (Ch-A, Ch-B), the math channel (Ch-C), maximum stored value of either input channel (Hi-A, Hi-B), minimum stored value of either input channel (Lo-A, Lo-B), relay set points, or the Modbus input.

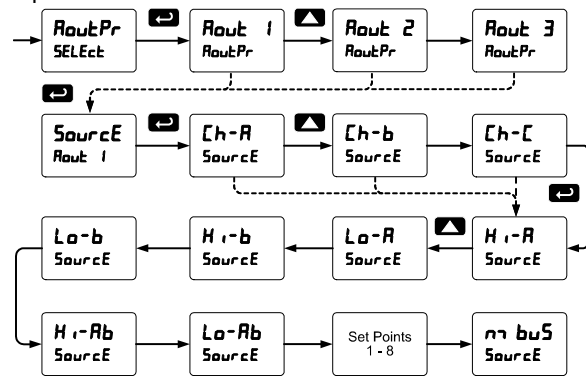

Analog Output Calibration

To perform the analog output calibration, it is recommended to use a milliamp meter with a resolution of at least 0.1 µA to measure the output current. The values saved internally during this procedure are used for scaling the 4-20 mA output in the *Setup* menu.

Programmable Function Keys User Menu (uSEr)

The *User* menu allows the user to assign the front panel function keys F1, F2, and F3, the digital input F4 (a digital input located on the input signal connector), and up to eight additional digital inputs to access most of the menus or to activate certain functions immediately (e.g. reset max & min, hold relay states, etc.). This allows the meter to be greatly customized for use in specialized applications.

Up to eight digital outputs can be assigned to a number of actions and functions executed by the meter (i.e. alarms, relay acknowledgement, reset max, min, or max & min, tare, and reset tare). The digital outputs can be used to trigger external alarms or lights to indicate these specific events.

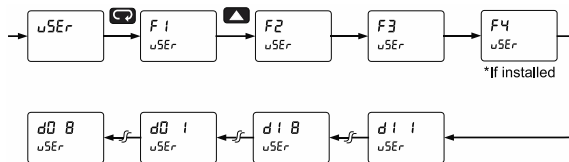

Function Keys & Digital I/O Available Settings

Refer to the following table for descriptions of each available function key or digital I/O setting.

Display	Description
rSt H I	Reset the stored maximum display values for all channels
rSt Lo	Reset the stored minimum display values for all channels
rSt HL	Reset the stored maximum & minimum display values for all channels
tRrE R	Capture tare and zero the display for channel A (A LED flashes – same rate as M)*
tRrE b	Capture tare and zero the display for channel B (B LED flashes – same rate as M)*
rSt tr	Reset captured tare and resume normal operation for both channels A & B
rELRY	Directly access the relay menu
SEt i*	Directly access the set point menu for relay 1 (*through 8)
rLY d	Disable all relays until a button assigned to <i>enable relays</i> (rLY E) is pressed
rLY E	Enable all relays to function as they have been programmed
d HoLd	Hold current relay states and analog output as they are until a button assigned to <i>enable relays</i> (rLY E) is pressed

Display	Description
d HoLd	Hold the current display value, relay states, and analog output momentarily while the function key or digital input is active. The process value will continue to be calculated in the background.
d RbC	Scrolls values for A, B & C when activated. Keeps the last value for 10 seconds and then it returns to its assignment. Values are displayed on display line 1 and the corresponding channel and units on display line 2.
Ln1 Hi	Display maximum channel A display value on line 1
Ln1 Lo	Display minimum channel A display value on line 1
Ln1 HL	Display maximum & minimum channel A display values on line 1
Ln2 Hi	Display maximum channel B display value on line 2
Ln2 Lo	Display minimum Channel B display value on line 2
Ln2 HL	Display maximum & minimum channel B display values on line 2
Ln3 HL	Display maximum channel C display value on line 2
Ln2 Hl	Display minimum channel C display value on line 2
Ln2 HL	Display maximum & minimum channel C display values on line 2
F On i*	Force relay 1 (*through 4) into the on state. This function is used in conjunction with a digital input expansion module to achieve interlock functionality. See <i>Setting Up the Interlock Relay (Force On) Feature</i> on page 32 for details.
Control	Directly access the control menu
d iSBbL	Disable the selected function key or digital I/O
RcH	Acknowledge all active relays that are in a manual operation mode such as auto-manual or latching
rESEt	Directly access the reset menu
nrEnu	Mimic the menu button functionality (digital inputs only)
r iRHt	Mimic the right arrow/F1 button functionality (digital inputs only)
uP	Mimic the up arrow/F2 button functionality (digital inputs only)
EntEr	Mimic the enter/F3 button functionality (digital inputs only)
Rlnr i*	Provide indication when alarm 1 (*through 8) has been triggered (digital outputs only)

* If math functions are displayed, the math function indicator LED “C” will flash when either A or B channel is using a tare value (net value).

Tare (Enter R, Enter b)

The tare function zero's out the display. In the case of scale weight, tare is used to eliminate container weight and provide net weight readings. There are two tare functions; Capture Tare for channel A and B, and Reset Tare. Display channel indicator letter flashes when a tare is used. It will flash until the tare is reset. The tare can be reset via the Reset menu, a function key, or a digital input.



Gross (without tare) and net (with tare) values can be viewed simultaneously. See *Setting the Display Parameter & Intensity (d5PLRY)* on page 25.

Internal Calibration (ICAL)

The meter is **factory calibrated** prior to shipment for milliamps and volts with calibration equipment that is certified to NIST standards.

The use of calibrated signal sources is necessary to perform the internal calibration of the meter. Check calibration of the meter at least every 12 months. Each input and input type must be recalibrated separately.

Notes:

1. If meter is in operation and it is intended to accept only one input type (e.g. 4-20 mA), recalibration of other input is not necessary.
2. Allow the meter to warm up for at least 15 minutes before performing the internal calibration procedure.

The *Internal calibration* menu is part of the *Advanced Features* menu.

1. Press and hold the Menu button for three seconds to access the advanced features of the meter.
2. Press the Up arrow button to scroll to the *Internal calibration* menu (ICAL) and press Enter.
3. Select channel A (Ch-A) or channel B (Ch-b) and press enter.
4. The meter displays either current calibration (ICAL) or voltage calibration (VICAL), according to the input setup. Press Enter to start the calibration process.

Example of Internal Calibration for current input:

5. The meter displays *low* input current message (Lo ICAL). Apply the low input signal and press Enter. The display flashes for a moment while the meter is accepting the low input signal.
6. After the display stops flashing, a number is displayed with the leftmost digit brighter than the rest. The bright digit is the active digit that can be changed by pressing the Up arrow button. Press the Right arrow button to move to the next digit.
7. Set the display value to correspond to the input signal being calibrated, typically 4.000 mA.

8. The display moves to the *high* input calibration (Hi ICAL). Apply the high input signal and press Enter.
9. Set the display for the high input calibration, in the same way as it was set for the low input calibration, typically 20.000 mA.

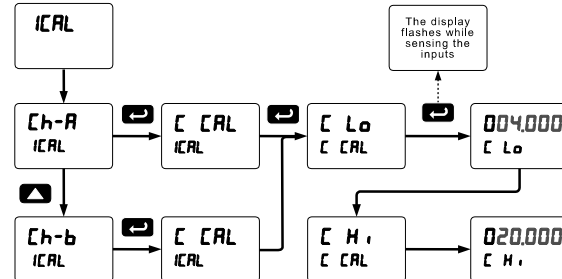

The graphic shows the calibration of the current input. The voltage input is calibrated in a similar way.

Tips:

- Low and high input signals can be any valid values within the range of the meter.
- Observe minimum input span requirements between input 1 and input 2.
- Low input should be less than high input signal.

Error Message (Error)

An error message indicates that the calibration or scaling process was not successful.

After the error message is displayed, the meter reverts to input 2 during calibration or scaling and to input 1 during internal calibration, allowing the appropriate input signal to be applied or programmed.

The error message might be caused by any of the following conditions:

5. Input signal is not connected to the proper terminals or it is connected backwards.
6. Wrong signal selection in *Setup* menu.
7. Minimum input span requirements not maintained.
8. Input 1 signal inadvertently applied to calibrate input 2.

Minimum Input Span

The minimum input span is the minimum difference between input 1 and input 2 signals required to complete the calibration or scaling of the meter.

Input Range	Input 1 & Input 2 Span
4-20 mA	0.15 mA
±10 VDC	0.10 VDC

Meter Operation





The meter is capable of accepting two input channels (A and B) of either current (0-20 mA, 4-20 mA) or voltage signals (0-5 V, 1-5 V, 0-10 V, ± 10 V) and displaying these signals in engineering units from -99999 to 999999 (e.g. a 4-20 mA signal could be displayed as -50.000 to 50.000).

A math function channel (C) is available to perform operations on channel A and B, with adder and factor constants, and display the results. Engineering units or tags may be displayed with these three channels.

The dual-line display can be customized by the user. Typically, the upper display is used to display the math channel C, while the lower display is used to alternate between displaying input channels A and B.

Additionally, the meter can be set up to display any input or math channel on the upper display and a unit or tag on the lower display. The relays and analog output can be programmed to operate based on any input or math channel.

Front Panel Buttons Operation

Button Symbol	Description
	Press to enter or exit Programming Mode, view settings, or exit max/min readings
	Press to reset max/min readings or other parameter/function assigned through the User menu
	Press to display max/min readings or other parameter/function assigned through the User menu
	Press to acknowledge relays or other parameters/function assigned through the User menu

Function Keys Operation

During operation, the programmable function keys operate according to the way they have been programmed in the *Advanced Features – User* menu. See *Programmable Function Keys User Menu* (u5Er) on page 40 for details.

The table above shows the factory default settings for F1, F2, and F3.

F4 Operation

A digital input, F4, is standard on the meter. This digital input is programmed identically to function keys F1, F2, and F3. The input is triggered with a contact closure to COM, or with an active low signal. During operation, F4 operates according to the way it has been programmed in the *Advanced Features – User* menu. See *Programmable Function Keys User Menu* (u5Er) on page 40 for details.

Maximum/Minimum Readings

The max & min readings (peak & valley) reached by the process can be displayed either continuously or momentary:

1. Display briefly by assigning to the F1-F3 function keys or to the digital inputs in the *User* menu.
2. Display continuously by assigning either display to max/min through the *Display* menu.

Any of the F1-F3 function keys (buttons) and the digital inputs can be programmed to reset the max & min readings. The meters are set at the factory to display the max reading by pressing the Up arrow/F2 button and to use the Right arrow/F1 button to access the *Reset* menu.

To display max and min channel A reading using function key with factory defaults:

1. Press Up arrow/F2 button to display minimum reading of channel A since the last reset/power-up. The display will then display the maximum reading of channel A since the last reset/power-up.
2. Press the Up arrow/F2 button again to display the minimum reading of channel A since the last reset/power up.
3. To reset max/min press Right arrow/F1 button to access the *Reset* menu. The max & min displays are reset to actual values.
4. Press Menu to exit max/min display reading.

Troubleshooting

The rugged design and the user-friendly interface of the meter should make it unusual for the installer or operator to refer to this section of the manual. However, due to the many features and functions of the meter, it's possible that the setup of the meter does not agree with what an operator expects to see. If the meter is not working as expected, refer to the *Diagnostics* menu and recommendations below.

Diagnostics Menu (d iRL)

The *Diagnostics* menu is located in the *Advanced Features* menu, to access *Diagnostics* menu see *Advanced Features Menu*, page 35.

This menu allows the user to test the functionality of all the meter LEDs, check the meter's software and version information, and erase the MeterView Pro software installation files from the meter. Press the Enter button to view the settings and the Menu button to exit at any time.

For a description of the diagnostic messages, see *Advanced Features Menu & Display Messages*, page 35.

Determining Software Version

To determine the software version of a meter:

1. Go to the *Diagnostics* menu (d iRL) and press Enter button.
2. Press Up arrow button and scroll to Information menu (i nF d).
3. Press Enter to access the software number (S F t) and version (U E r) information. Write down the information as it is displayed. Continue pressing Enter until all the information is displayed.
4. The meter returns to Run Mode after displaying all the settings.

Reset Meter to Factory Defaults

When the parameters have been changed in a way that is difficult to determine what's happening, it might be better to start the setup process from the factory defaults.

Instructions to load factory defaults:

1. Enter the *Advanced Features* menu. See *Advanced Features Menu*, page 35.
2. Press Up arrow to go to *Diagnostics* menu
3. Press and hold Right arrow for three seconds, press Enter when display flashes reset.
Note: If Enter is not pressed within three seconds, the display returns to Run Mode.
4. The meter goes through an initialization sequence (similar as on power-up), and loads the factory default settings.

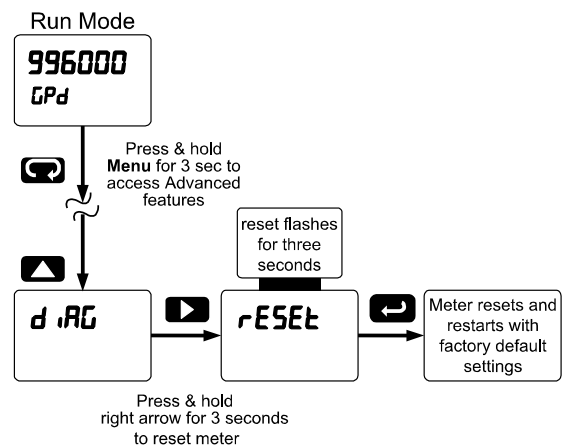

Factory Defaults & User Settings

The following table shows the factory setting for most of the programmable parameters on the meter.

Factory Defaults & User Settings		
Parameter	Display	Default Setting
Input type	i nP u t	
Input type, channel A	[h - R	4-20 mA
Input type, channel B	[h - b	4-20 mA
Unit	u n i t	
Unit, channel A	[h - R	mA-A
Unit, channel B	[h - b	mA-b
Unit, channel C	[h - [mA-C
Number of points	n o P t s	
Number of points, ch A	[h - R	2
Number of points, ch B	[h - b	2
Scaling, (channel A)	S c R L R	
Input 1, channel A	i nP 1	4.000 mA
Display 1, channel A	d iS 1	4.000
Input 2, channel A	i nP 2	20.000 mA
Display 2, channel A	d iS 2	20.000
Scaling (channel B)	S c R L b	

Factory Defaults & User Settings		
Parameter	Display	Default Setting
Input 1, channel B	inP 1	4.000 mA
Display 1, channel B	d 15 1	4.000
Input 2, channel B	inP 2	20.000 mA
Display 2, channel B	d 15 2	20.000
Math, channel C	Sum	Sum
Adder (constant P)	AddEr	0.000
Factor (constant F)	Factor	1
Filter	Filter	
Filter, channel A	[h-R	70
Filter, channel B	[h-b	70
Bypass, channel A	bypass	0.2
Bypass, channel B	bypass	0.2
Round	round	1
Cutoff	Cutoff	
Cutoff value, channel A	[h-R	0.000 (disabled)
Cutoff value, channel B	[h-b	0.000 (disabled)
Display assignment	display	
Display line 1	d [h-R	Channel A
Display line 2	d [h-b	Channel B
Display intensity	d-intensity	8
Relay 1 assignment	[h-R	Channel A
Relay 1 action	Relc 1	Automatic
Relay 1 set point	SEt 1	1.000
Relay 1 reset point	rSEt 1	0.500
Relay 2 assignment	[h-R	Channel A
Relay 2 action	Relc 2	Automatic
Relay 2 set point	SEt 2	2.000
Relay 2 reset point	rSEt 2	1.500
Relay 3 assignment	[h-R	Channel A
Relay 3 action	Relc 3	Automatic
Relay 3 set point	SEt 3	3.000
Relay 3 reset point	rSEt 3	2.500
Relay 4 assignment	[h-R	Channel A
Relay 4 action	Relc 4	Automatic
Relay 4 set point	SEt 4	4.000
Relay 4 reset point	rSEt 4	3.500
Fail-safe relay 1	FLS 1	Off
Fail-safe relay 2	FLS 2	Off
Fail-safe relay 3	FLS 3	Off
Fail-safe relay 4	FLS 4	Off
On delay relay 1	On 1	0.0 sec
Off delay relay 1	OFF 1	0.0 sec
On delay relay 2	On 2	0.0 sec

Factory Defaults & User Settings		
Parameter	Display	Default Setting
Off delay relay 2	OFF 2	0.0 sec
On delay relay 3	On 3	0.0 sec
Off delay relay 3	OFF 3	0.0 sec
On delay relay 4	On 4	0.0 sec
Off delay relay 4	OFF 4	0.0 sec
Loop break relay 1	LnbrE	Ignore
Loop break relay 2	LnbrE	Ignore
Loop break relay 3	LnbrE	Ignore
Loop break relay 4	LnbrE	Ignore
Display 1 analog out	d 15 1	4.000
Output 1 value	Out 1	4.000 mA
Display 2 analog out	d 15 2	20.000
Output 2 value	Out 2	20.000 mA
Source analog output	SourceE	Channel A
Overrange output	Or-rAnE	21.000 mA
Underrange output	u-rAnE	3.000 mA
Loop break output	brERH	3.000 mA
Maximum output	maxH	23.000 mA
Minimum output	min	3.000 mA
Slave ID (Address)	SLRw id	247
Baud rate	baud	9600
Transmit delay	tr dLY	50 ms
Parity	PRr intY	Even
Byte-to-byte timeout	t-bLYt	010 (0.1 sec)
F1 function key	F 1	Reset max & min
F2 function key	F 2	Upper Max & Min
F3 function key	F 3	Acknowledge relays
F4 function (digital input)	F 4	Acknowledge relays
Digital input 1	d i 1	Menu
Digital input 2	d i 2	Right arrow
Digital input 3	d i 3	Up arrow
Digital input 4	d i 4	Enter
Digital output 1	do 1	Alarm 1
Digital output 2	do 2	Alarm 2
Digital output 3	do 3	Alarm 3
Digital output 4	do 4	Alarm 4
Password 1	PRSS 1	000000 (unlocked)
Password 2	PRSS 2	000000 (unlocked)
Password 3	PRSS 3	000000 (unlocked)

Troubleshooting Tips

This meter is a highly sophisticated instrument with an extensive list of features and capabilities. If the front panel buttons are used to program the meter, it may be a difficult task to keep everything straight. That is why we strongly recommend the use of the free [MeterView Pro](#) software for all programming activities. A cable is provided with the meter for programming with MeterView Pro software.

If you have programmed the meter with the front panel buttons and it is not working as intended, try re-programming the meter using MeterView Pro software.

Symptom	Check/Action
No display at all	Check power at power connector
Not able to change setup or programming, LoCd is displayed	Meter is password-protected, enter correct six-digit password to unlock
Meter does not respond to input change	If a <i>Low-Flow Cutoff Value</i> has been programmed, the meter will display zero below that point, regardless of the input – which can appear like the meter is not responding to an input change. Check to make sure the problem is not being caused by an undesired low-flow cutoff value.
Meter displays error message during calibration (Error)	Check: 1. Signal connections 2. Input selected in <i>Setup</i> menu 3. Minimum input span requirements
Meter displays 1. 999999 2. -999999	Check: 1. Input selected in <i>Setup</i> menu 2. Corresponding signal at Signal connector
Display is unstable	Check: 1. Input signal stability and value 2. Display scaling vs. input signal 3. Filter and bypass values (increase)
Display response is too slow	Check filter and bypass values
Display reading is not accurate	Check: 1. Input signal conditioner selected: Linear, square root, etc. 2. Scaling or calibration
Display does not respond to input changes, reading a fixed number	Check: 1. Display assignment, it might be displaying max, min, or set point.
Display alternates between 1. H i and a number 2. Lo and a number	Press Menu to exit max/min display readings.
Relay operation is reversed	Check: 1. Fail-safe in <i>Setup</i> menu 2. Wiring of relay contacts
Relay and status LED do not respond to signal	Check: 1. Relay action in <i>Setup</i> menu 2. Set and reset points
Flashing relay status LEDs	Relays in manual control mode or relay interlock switches opened.
Meter not communicating with application programs	Check: 1. Serial adapter and cable 2. Serial settings 3. Meter address and baud rate
If the display locks up or the meter does not respond at all	Cycle the power to reboot the microprocessor.
Other symptoms not described above	Call Technical Support for assistance.

Note: Certain sequences of events can cause unexpected results. To solve these issues, it is best to start fresh from factory defaults and use the manual as a step by step programming guide, rather than a random approach to programming. To reset the meter to factory defaults, see Reset Meter to Factory Defaults on page 43. In addition, for best results, we recommend using the free MeterView Pro software for all programming needs.



EU Declaration of Conformity

Issued in accordance with ISO/IEC 17050-1:2004.

We,

Precision Digital Corporation
233 South Street
Hopkinton, MA 01748 USA

as the manufacturer, declare under our sole responsibility that the product(s),

Model PD6060 ProVu Series Dual-Input Process Meter

to which this declaration relates, is in conformity with the European Union Directives shown below:

2014/35/EU	Low Voltage Directive
2014/30/EU	EMC Directive
2011/65/EU	RoHS Directive

This conformity is based on compliance with the application of harmonized or applicable technical standards and, when applicable or required, a European Union notified body certification.

Standards:

EN 55022:2003
EN 61000-6-2:2001
EN 61010-1:2001
EN 61326:2006

The standards EN 55022:2003, EN 61000-6-2:2001, EN 61010-1:2001, and EN 61326:2006 are no longer harmonized. The requirements of these standards have been checked against the harmonized standards EN 55022:2010, EN 61000-6-2:2005, EN 61010-1:2010, and EN 61326:2013 and there were no major technical changes affecting the latest technical knowledge for the products listed above.

Product Markings:



Signed for and on behalf of Precision Digital Corporation:



Name: Jeffrey Peters
Company: Precision Digital Corporation
Title: President
Date: 04/20/2016

Document No: DoC PD6060 {042016}

Contact Precision Digital

Technical Support

Call: (800) 610-5239 or (508) 655-7300

Fax: (508) 655-8990

Email: support@predig.com

Sales Support

Call: (800) 343-1001 or (508) 655-7300

Fax: (508) 655-8990

Email: sales@predig.com

Place Orders

Email: orders@predig.com

For the latest version of this manual please visit

www.predig.com

PRECISION DIGITAL CORPORATION

233 South Street • Hopkinton MA 01748 USA

Tel (800) 343-1001 • Fax (508) 655-8990

www.predig.com

