

Diaphragm seal for fermenter Type series DE2110



Features

- Flush-mounted separating diaphragm of stainless steel or special material
- Screw-type diaphragm seal, screwed plug adjustable
- Volume optimised diaphragm base
- System fillings for different applications

Options

- Certificates
 - Material certificate acc. to EN 10204-3.1
- Electropolishing (wetted parts)
- Hygienic design with advanced surface quality
- Special materials upon request

Application

Suitable for mounting to pressure transmitters. The diaphragm seal is used mainly for dead-zone free pressure measurement.

Application area

- Food industry
- Pharmaceutical industry
- Biotechnology

Technical data

Constructional design

Basic body:	Volume reduced diaphragm base Material: stainless steel mat.-no. 1.4404/1.4435 (316L) Further materials upon request
Diaphragm:	Flat diaphragm
Material wetted parts:	Diaphragm: Stainless steel mat.-no. 1.4435 (316L), alternative Hastelloy C276. Further materials upon request. Basic body: stainless steel mat.-no. 1.4435 (316L)

Process connection

Design:	Screw-in thread, Rd 28 x 1/8
Nominal pressure:	PN 40
Gaskets:	<ul style="list-style-type: none">■ Material NBR 70 (Perbunan), temperature range: -25...120 °C■ Material EPDM, FDA compliant, temperature range: -50...140 °C

Measuring device connection

See order details.

System filling

See order details; further upon request.
Further details about pressure transmission fluids see general technical information TA_038.

Hygienic design

The surface roughness of the wetted parts made of stainless steel are executed according to EHEDG Doc.8 and ASME BPE SF3.
In case of choosing the additional feature HY, we guarantee the following surface roughness values:

Diaphragm foil:	Ra ≤ 0.38 µm
Laser welds:	Ra ≤ 0.76 µm
Turned parts:	Ra ≤ 0.76 µm

Further versions of hygienic design upon request.

Temperature error

In order to optimise the system we provide a detailed error calculation upon request.

Weight

With measuring device connection approx. 0.3 kg

Further information about diaphragm seals see general technical information TA_031.

Dimensions

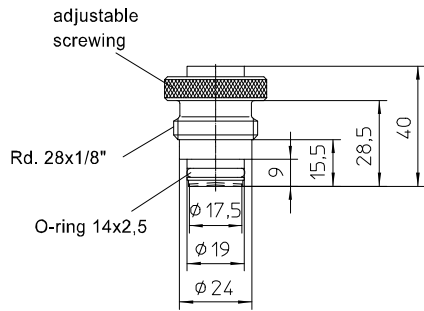

Order details

Diaphragm seal for fermenter Type series DE2110

Order details diaphragm seal DE2110

DE2110	design	screwed plug adjustable Rd 28 x 1/8	
		standard	
HY	surface roughness	Hygienic version as per EHEDG Doc.8 and ASME BPE SF3	
D10	process connection	Rd 28 x1/8 Ø 19 x 40, standard	
D20		Rd 28 x1/8 Ø 19 x 44,5	
A400 .	measuring device connection	directly welded	
7	diaphragm material	stainless steel mat.-no. 1.4435 (316L)	
3		Hastelloy C 276	
9		variant	
E7	basic body material	stainless steel mat.-no. 1.4435 (316L)	
E9		variant	
G1	gasket	NBR 70 (Perbunan), temperature range -25...120 °C	
G2		EPDM FDA konform, temperature range -50...140 °C	
G9		variant	
	system filling ¹	<u>pressure transmission fluid</u>	<u>temperature range</u> ²
L22		synthetic oil, free of silicone FD1, standard	-10...140 °C
L23		synthetic oil, free of silicone FD1, pls. specify max. temperature	-40...230 °C ²
L15		glycerine/water FGW	-30...110 °C

Additional features (to be indicated in case of need, only)

W1020	material certificate per EN 10204-3.1, wetted parts
W4035	Electropolishing of wetted parts

Order code (example): DE2110 - D10 - A4007 - E7 - G1 - L22 - ...

¹ for more detailed information about pressure transmission fluids see TA_038.

Please state temperature range to allow an accurate calculation of the system.

² max. media temperature for pressures > 0 bar rel. The temperature range of the used gasket has to be observed.