

## Diaphragm pressure gauge with switch contact, NS 100/160 Type series BE2...



### Application area

- General process technology
- Chemical and petrochemical industry
- Machinery construction
- Shipping

### Features

- Diaphragm pressure gauge with switch contact
- High quality case with bajonet ring NS 100/160 per EN 837-3 S1, alternative safety version per EN 837-1 S3
- Case and measuring flange of stainless steel, diaphragm of Duratherm
- High overload protection
- Nominal range -1...0 bar to -1...24 bar, 0...25 mbar to 0...25 bar
- Accuracy class as per DIN 16085
- Switch contacts (electrical contact devices) per DIN 16085:
  - slow acting contact
  - magnetic snap contact
  - inductive contact
  - inductive contact with integrated switching amplifier

### Options

- Approvals/Certificates
  - Explosion protection
  - Classification per SIL2
  - Certificate of measuring equipment for Russian Federation
  - Material certificate per EN 10204
  - Calibration certificate per EN 10204
- Higher overload protection
- Case with liquid filling
- Electronical angle-of-rotation sensor, Type series PL1100, see data sheet D6-020
- Extended temperature range
- Connection to Zone 0
- EAC declaration (upon request)

### Application

Can be used as an excess pressure gauge with switch contact for measuring liquids and gases. Because of its robust design, it is suitable for use in tough environments.

## Technical data

### Constructional design / case

Design: High quality case with bajonet ring per EN 837-3 S1, material: stainless steel mat.-no. Nr. 1.4301 (304). With rear blow-out device, material: PUR, ventilation valve, material: PUR

#### Alternative:

Safety design with blow-out back and solid baffle wall per EN 837-1 S3, Material: Stainless steel 1.4301 (304)

Nominal size: NS 100 or NS 160

Degree of protection per EN 60529:

- Without filling: IP 65
- With filling S1 case: IP 65
- With filling S3 case: IP 66

Case filling: Labofin

Atmosph. pressure compensation: Via ventilation valve.

Case seal: Material gasket: NBR

Pressure chamber seal: Material: NBR, optional PTFE. Further materials upon request.

Window: Non-splintering laminated glass. Option: Non-splintering plastic (Macrolon)

Contact lock: Stainless steel with NBR gasket

Measuring element: Diaphragm

Movement: Stainless steel segment

Scale: Pure aluminium, white with black inscription  
Option: with red marking  
Special scale upon request

Pointer: Pure aluminium, black, with micro adjustment for zero point correction

Mounting: Via process connection

Electronical connection: Connection plug with cable gland M20 x 1.5 and removable test cover, material: Macrolon

Weights: NS 100:

- flange Ø 100 without filling: approx. 2.0 kg
- flange Ø 160 without filling: approx. 3.4 kg
- flange Ø 100 with filling: approx. 2.5 kg
- flange Ø 160 with filling: approx. 3.9 kg

NS 160:

- flange Ø 100 without filling: approx. 2.3 kg
- flange Ø 160 without filling: approx. 3.8 kg
- flange Ø 100 with filling: approx. 3.3 kg
- flange Ø 160 with filling: approx. 4.8 kg

### Process connection

Design: Per EN 837-3, G1/2 B, 1/2" NPT or open measuring flange. Further process connections upon request.

### Material wetted parts

Measuring element: Diaphragm: Duratherm (similar resistance as mat.-no. 1.4571 (316Ti)), alternatively with:

- PTFE foil
- PFA coating
- Monel foil
- Hastelloy C 276 foil
- Tantal foil
- Stainless steel foil

Measuring flange: Stainless steel mat.-no. 1.4571, alternatively with:

- PTFE lining
- PFA coating
- PVDF

Further materials upon request.

### Nominal range

See order details, further ranges upon request

Overload protection: Flange Ø 100:  
Standard: short term 5times, max. 100 bar  
Option: 20times, max. 100 bar  
Flange Ø 160:  
Standard: 50times

### Accuracy

Accuracy class:	NS 100			
	nominal range (mbar)	no. of contacts		
	1	2	3	
≥ 25	cl. 1.6	cl. 2.5	-	
≥ 60	cl. 1.6	cl. 1.6	cl. 2.5	
Acc	NS 160			
	nominal range (mbar)	no. of contacts		
	1	2	3	
≥ 25	cl. 1.6	-	-	
≥ 60	cl. 1.6	cl. 2.5	-	
≥ 160	cl. 1.6	cl. 1.6	-	
≥ 600	cl. 1.6	cl. 1.6	cl. 2.5	

Plus effect of switch function on indication per DIN 16085.

Temperature influence: Max. ± 0.8% / 10K of measuring span per EN 837-3.

## Temperature ranges

	without filling	with filling
Ambient:	-20...70 °C	-20...70 °C (60 °C) <sup>1</sup>
Medium:	-20...110 °C	-20...70 °C (60 °C) <sup>1</sup>
Storage:	-40...70 °C	-40...70 °C (-20...60 °C) <sup>1</sup>

Extended temperature range (optional): <sup>2</sup>

	without filling	with filling
Ambient:	-40...100 °C	-40...80 °C (60 °C) <sup>1</sup>
Medium:	-40...150 °C	-40...150 °C <sup>3</sup>

Devices with classification per SIL2:

	without filling	with filling
Ambient:	-20...60 °C	-20...60 °C(40 °C) <sup>1</sup>
Medium:	-20...60 °C	-20...60 °C(40 °C) <sup>1</sup>

<sup>1</sup> Safety case S3 (IP 66)

<sup>2</sup> Inductive safety initiator necessary

<sup>3</sup> Limitation: nominal range ≤ 1 bar up to 110 °C

## Tests and certificates

Ex-protection: Magnetic snap contact:  
Simple electrical apparatus per IEC/DIN EN 60079-11 suitable for intrinsically safe circuits Ex IIC TX.

Inductive contact:

Contact device suitable for intrinsically safe circuits

II 2G Ex ia IIC T4/T5/T6 Gb

Reg.-no.: ■ PTB 99 ATEX 2219X  
■ PTB 00 ATEX 2049X

Ex-protection (ATEX) for mechanical devices:

II 2G Ex h IIC T1...T6 Gb X

II 2D Ex h IIIC Txx°C Db X

Further details see operation instruction BA\_037 and Ex Instructions XA\_005, XA\_013, XA\_014 and XA\_021.

SIL 2: Functional safety per EN 61508, classification per SIL 2  
For devices with inductive contact only (Typ N1, N2 and N4).

- EAC declaration (upon request)
- Certificate of measuring equipment for Russian Federation

## Switch contacts

Slow acting contact: Type L2

- max. 3 touch contacts
- Contact load: 10 W / 18 VA
- Switching up to 230 V DC
- Available with separate circuit (Type M2)

Magnetic snap contact: Type L4

- max. 3 touch contacts
- Contact load: 30 W / 50 VA
- Switching up to 230 V DC
- Available with separate circuit (Type M4)

Inductive contact: (standard) Type N4

- max. 3 contacts, contactless
- Control unit required, see product group M7

Inductive contact: (SN) Type N1

- Safety initiator
- max. 3 contacts, contactless
- Control unit required, see product group M7

Inductive contact inverse: (S1N) Type N2

- Safety initiator, inverse switching
- max. 2 contacts, contactless
- Control unit required, see product group M7

Inductive contact with integrated amplifier: Type N6

- max. 2 contacts, contactless
- 100 mA
- 3-wire technology, suitable for direct activation at a PLC

Further information see operating instruction BA\_037 and Technical Information TA\_039.

# Dimensions

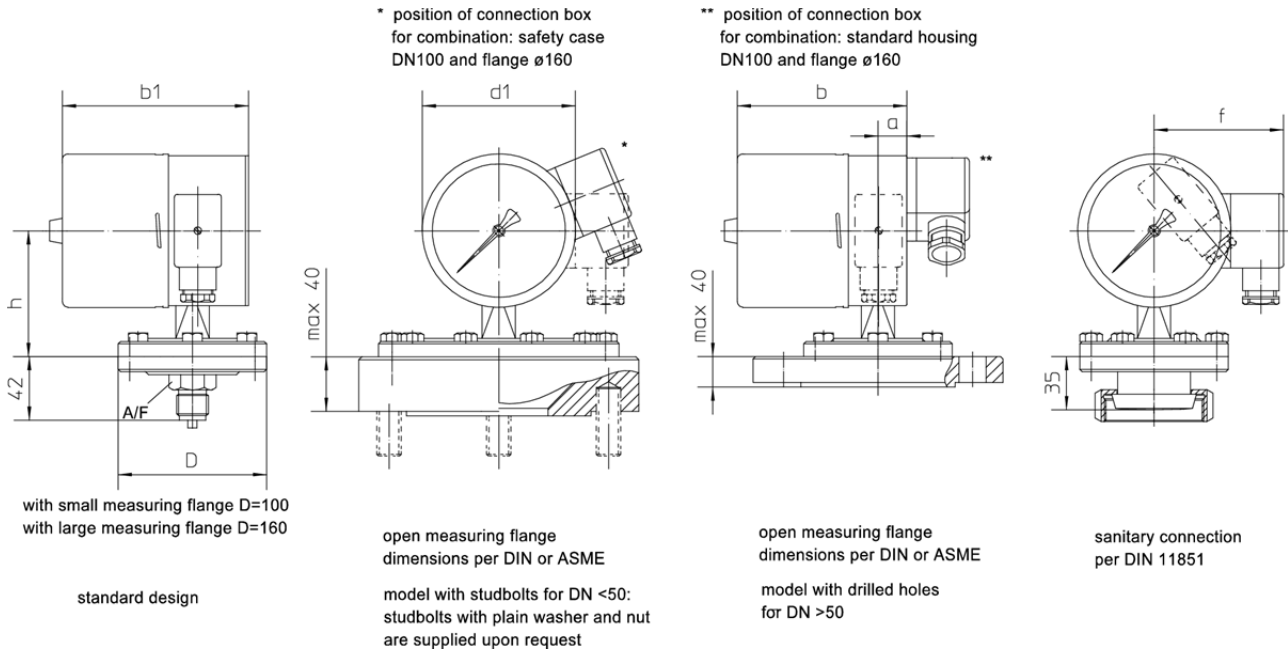

All dimensions are in millimeters

Dimensions (mm)							
				IP 65		IP 66	
case	f	d1	a	b	a1	b1	h
NS 100	89	100	19	112	37	124	83
NS 160	119	160	19	114	47	136	113

## Order details

### Diaphragm pressure gauge with switch contact NS 100/160, Type series BE2 . . .

Order details BE2..					
BE220 .	case design	NS 100	IP 65 without liquid filling		
BE222 .			IP 65 with liquid filling		
BE230 .		NS 160	IP 65 without liquid filling		
BE232 .			IP 65 with liquid filling		
BE250.		NS 100 acc. to EN 837-1 S3	IP 65 without liquid filling		
BE254.			IP 66 with liquid filling		
BE260.		NS 160 acc. to EN 837-1 S3	IP 65 without liquid filling		
BE264.			IP 66 with liquid filling		
0	design	standard			
1		Ex-protection			
A1011	nominal range	measuring flange Ø 100 mm	0...400 mbar		
A1052			0...0.6 bar		
A1053			0...1 bar		
A1054			0...1.6 bar		
A1055			0...2.5 bar		
A1056			0...4 bar		
A1057			0...6 bar		
A1058			0...10 bar		
A1059			0...16 bar		
A1060			0...25 bar		
A1028			-400...0 mbar		
A1085			-0.6...0 bar		
A1086			-1...0 bar		
A1087			-1...0.6 bar		
A1088			-1...1.5 bar		
A1089			-1...3 bar		
A1090			-1...5 bar		
A1091			-1...9 bar		
A1092			-1...15 bar		
A1093			-1...24 bar		
A1005			measuring flange Ø 160 mm	0...25 mbar	
A1006				0...40 mbar	
A1007				0...60 mbar	
A1008				0...100 mbar	
A1009				0...160 mbar	
A1010				0...250 mbar	
A1022				-25...0 mbar	
A1023				-40...0 mbar	
A1024		-60...0 mbar			
A1025		-100...0 mbar			
A1026		-160...0 mbar			
A1027		-250...0 mbar			
D10011		process connection		screwed connection	G 1/2 B, material 1.4571 (316Ti)
D10021					G 1/2 B, material 1.4571 (316Ti), with 12 mm drilling
D10012	G 1/2 B, Material 1.4571 (316Ti), PTFE coating <sup>1</sup>				
D10017	G 1/2 B, PVDF (PN to max. 16 bar)				
D10201	1/2" NPT, material 1.4571 (316Ti)				
D20101	open meas. flange PN10...40 mat. 1.4571 (316Ti) sealing surface DIN EN 1092-1 model B1 (DIN 2526 Form C)		DN 25, for studbolts		
D20102			DN 25, for studbolts, with PTFE liner <sup>1</sup>		
D20131			DN 50, for meas. ranges ≤ 250 mbar for studbolts		
			DN 50, for meas. ranges ≥ 400 mbar with drilled hole		
D20132			DN 50, with PTFE liner, for meas. ranges ≤ 250 mbar for studbolts <sup>1</sup>		
			DN 50, with PTFE liner, for meas. ranges ≥ 400 mbar for studbolts <sup>1</sup>		

	switch contacts	type of contact	number
L4 . 00	touch contact	magnetic snap contact	single contact
L4 . . 0			double contact
L4 . . .			triple contact
L2 . 00		slow acting contact <sup>2</sup>	single contact
L2 . . 0			double contact
L2 . . .			triple contact
M4 . . 0		magnetic snap contact, separated circuits	double contact
M4 . . .			triple contact
M2 . . 0		slow acting contact <sup>2</sup> separated circuits	double contact
M2 . . .			triple contact

N4 . 00	Inductive contact	standard initiator (N)	single contact
N4 . . 0			double contact
N4 . . .			triple contact
N1 . 00		safety initiator (SN)	single contact
N1 . . 0			double contact
N1 . . .			triple contact
N2 . 00		safety initiator invers (S1N)	single contact
N2 . . 0			double contact
N6 . 00		Inductive contact with integrated switching amplifier, 3-wire technology PNP <sup>2</sup>	single contact
N6 . . 0			double contact

...	switch function - per contact, replace point with number		
1	switch	increasing pressure makes contact	
2		increasing pressure breaks contact	
4		decreasing pressure makes contact	
5		decreasing pressure breaks contact	
3	change-over element	increasing pressure makes or breaks contact	
6		decreasing pressure makes or breaks contact	

Additional features (to be indicated if required)			
H102	gasket	pressure chamber seal, gasket PTFE	
H112	diaphragm lining / resp. protective foil	PFA red lining, gasket PTFE	
H132		Monel foil from $\geq 4$ bar, gasket PTFE <sup>3</sup>	
H142		Hastelloy C276 protective foil from $\geq 4$ bar, gasket PTFE <sup>3</sup>	
H162		Tantalum protective foil from $\geq 4$ bar, gasket PTFE <sup>3</sup>	
PL1100-	output signal	4...20 mA (20...4 mA) with electr. angle-of-rotation sensor (see D6-020)	
T2	marking	on scale (please specify)	
W2603	functional safety per EN 61508, classification per SIL 2 <sup>6</sup>		
W2673	certificate of measuring equipment for Russian Federation		
W4010	overload protected	20times (meas. range $\geq 100$ bar), kurzfristig, für Messflansch 100 mm	
Z1	connection to Zone 0 <sup>4</sup>	with Zone 0 adapter (coupler element KF6) <sup>5</sup>	

Order code (example): BE2641 – A1056 – D10011 – N4100 - ...

<sup>1</sup> PN up to max. 25 bar

<sup>2</sup> not for devices with Ex-protection

<sup>3</sup> for nominal range  $\geq 1$  bar, vacuum max. -500 mbar at 10 to 30 °C

<sup>4</sup> for devices with Ex-protection, only - not with magnetic snap contact

<sup>5</sup> with threaded connection G 1/2 B, mat. 1.4571 (316Ti), only

<sup>6</sup> for devices with inductive contact only