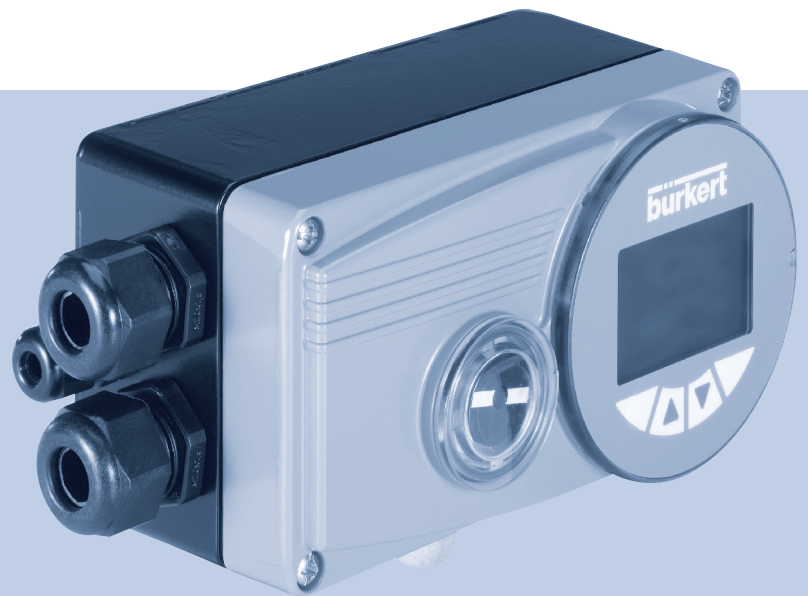


## Type 8792, 8793 REV.2

Electropneumatic positioner and process controller



We reserve the right to make technical changes without notice.

© Bürkert Werke GmbH & Co. KG, 2017-2019

Operating Instructions 1912/02\_EN-en\_00810648 / Original DE

## General information and safety instructions

### CONTENTS

<b>1</b>	<b>THE OPERATING INSTRUCTIONS .....</b>	<b>7</b>
1.1	Symbols.....	7
1.2	Definition of terms.....	7
<b>2</b>	<b>INTENDED USE .....</b>	<b>8</b>
<b>3</b>	<b>BASIC SAFETY INSTRUCTIONS .....</b>	<b>9</b>
<b>4</b>	<b>GENERAL INFORMATION.....</b>	<b>10</b>
4.1	Contact addresses.....	10
4.2	Warranty .....	10
4.3	Master code .....	10
4.4	Information on the Internet.....	10
<b>5</b>	<b>PRODUCT DESCRIPTION.....</b>	<b>11</b>
5.1	General description.....	11
5.2	Properties.....	11
5.3	Variants.....	14
<b>6</b>	<b>STRUCTURE AND FUNCTION.....</b>	<b>15</b>
6.1	Representation.....	15
6.2	Function diagram .....	16
<b>7</b>	<b>POSITIONER TYPE 8792 .....</b>	<b>17</b>
7.1	Schematic representation of the position control .....	18
7.2	The positioner software.....	19
<b>8</b>	<b>PROCESS CONTROLLER TYPE 8793.....</b>	<b>21</b>
8.1	Schematic representation of process control .....	22
8.2	The process controller software.....	23
<b>9</b>	<b>INTERFACES .....</b>	<b>25</b>
<b>10</b>	<b>TECHNICAL DATA .....</b>	<b>26</b>
10.1	Conformity.....	26

10.2	Standards .....	26
10.3	Approvals .....	26
10.4	Operating conditions .....	26
10.5	Type label .....	27
10.6	Mechanical data.....	27
10.7	Electrical data .....	28
10.8	Pneumatic data .....	29
10.9	Safety end positions after failure of the electrical or pneumatic auxiliary power.....	30
<b>11</b>	<b>ASSEMBLY .....</b>	<b>31</b>
11.1	Safety instructions .....	31
11.2	Attachment to a continuous valve with linear actuator according to NAMUR.....	31
11.3	Attachment to a continuous valve with rotary actuator .....	36
11.4	Remote operation with external position sensor.....	38
11.5	Pneumatic connection.....	41
<b>12</b>	<b>ELECTRICAL INSTALLATION.....</b>	<b>43</b>
12.1	Electrical installation with circular plug-in connector (multipole version).....	43
12.2	Electrical installation with cable gland.....	48
<b>13</b>	<b>OPERATION.....</b>	<b>52</b>
13.1	Description of the operating and display elements.....	52
13.2	Function of the keys.....	54
13.3	Adjusting the display .....	57
13.4	Date and time .....	59
13.5	Operating states.....	60
13.6	Activating and deactivating auxiliary functions.....	61
13.7	Manually opening and closing the valve.....	63
<b>14</b>	<b>START-UP .....</b>	<b>64</b>
14.1	Safety instructions .....	64
14.2	Basic setting of the device .....	65
14.3	<i>INPUT</i> - Setting the input signal.....	65
14.4	<i>X.TUNE</i> – Automatic adjustment of the position controller .....	66
14.5	Activation of the process controller .....	68

15	BASIC SETTING OF THE PROCESS CONTROLLER.....	69
15.1	<i>P.CONTROL</i> – Setting up and parameterization of the process controller .....	69
15.2	<i>SETUP</i> – Setting up the process controller .....	70
15.3	<i>PID.PARAMETER</i> – Parameterizing the process controller .....	76
15.4	<i>P.Q’LIN</i> – Linearization of the process characteristic .....	80
15.5	<i>P.TUNE</i> – Self-optimization of the process controller .....	81
16	AUXILIARY FUNCTIONS .....	85
16.1	Activating and deactivating auxiliary functions.....	86
16.2	Manual configuration of <i>X.TUNE</i> .....	141
17	ACCESS TO THE BÜS SERVICE INTERFACE.....	145
17.1	Setting options for start-up via Bürkert-Communicator .....	145
18	OPERATING STRUCTURE AND FACTORY SETTING .....	147
19	ETHERNET/IP, PROFINET AND MODBUS TCP .....	162
19.1	Technical data .....	162
19.2	Industrial Ethernet.....	162
19.3	X7 - M12 fieldbus connection D-coded.....	165
19.4	X1 - M12 circular plug, 8-pole .....	165
19.5	X4 - M8 socket, 4-pole, optional - Remote sensor (for remote variant only) .....	165
19.6	X5 - M8 circular plug, 4-pole - Process actual value (for Type 8793).....	166
19.7	Bus status display.....	167
20	BÜS OPTION .....	169
20.1	Definition .....	169
20.2	Interfaces.....	169
20.3	Electrical installation - büS.....	169
20.4	X1 - M12 circular plug, 8-pole .....	171
20.5	X4 - M8 socket, 4-pole, optional - Remote sensor (for remote variant only) .....	172
20.6	X5 - M8 circular plug, 4-pole - Process actual value (for Type 8793).....	172
20.7	<i>BUS.COMM</i> – Settings on Type 8792, 8793 .....	173
21	MAINTENANCE AND TROUBLESHOOTING .....	175
21.1	Safety instruction .....	175

21.2	Maintenance.....	175
21.3	Error messages .....	175
21.4	Malfunctions.....	179
22	ACCESSORIES .....	180
22.1	Communication software.....	180
22.2	Download .....	180
22.3	USB interface .....	180
23	PACKAGING, TRANSPORT.....	181
24	STORAGE .....	181
25	DISPOSAL .....	181
26	SUPPLEMENTARY INFORMATION .....	182
26.1	Selection criteria for continuous valves.....	182
26.2	Properties of PID controllers .....	184
26.3	Adjustment rules for PID controllers.....	189
27	TABLE FOR YOUR SETTINGS ON THE POSITIONER .....	193
27.1	Settings of the freely programmed characteristic.....	193
28	TABLE FOR YOUR SETTINGS ON THE TYPE 8793 PROCESS CONTROLLER .....	194
28.1	Set parameters of the process controller .....	194

# 1 THE OPERATING INSTRUCTIONS

The operating instructions describe the entire life cycle of the device. Keep these instructions in a location which is easily accessible to every user and make these instructions available to every new owner of the device.

## Important safety information.

Read the operating instructions carefully and thoroughly. Study in particular the chapters entitled *Basic safety instructions* and *Intended use*.

- ▶ The operating instructions must be read and understood.

## 1.1 Symbols



### DANGER

Warns of an immediate danger.

- ▶ Failure to observe the warning will result in fatal or serious injuries.



### WARNING

Warns of a potentially dangerous situation.

- ▶ Failure to observe the warning may result in serious injuries or death.



### CAUTION

Warns of a possible danger.

- ▶ Failure to observe this warning may result in a moderate or minor injury.

### NOTE

Warns of damage to property.

- ▶ Failure to observe the warning may result in damage to the device or other equipment.



Indicates important additional information, tips and recommendations.



Refers to information in these operating instructions or in other documentation.

- ▶ Indicates instructions for risk prevention.

→ Indicates a procedure which you must carry out.

- ✔ Indicates a result.

## 1.2 Definition of terms

In these instructions, the term “device” always refers to the Type 8792, 8793 REV.2.

## 2 INTENDED USE

Use the device for its intended purpose only. Non-intended use of the device may be dangerous to people, nearby equipment and the environment.

The device is designed to be mounted on pneumatic actuators of process valves for the control of media.

- ▶ In potentially explosive atmospheres, Type 8792 and 8793 may be used only in accordance with the specification on the separate Ex type label. For the use, observe the ATEX manual with safety instructions for potentially explosive atmospheres.
- ▶ Devices without a separate Ex type label may not be used in potentially explosive atmospheres.
- ▶ Do not expose the device to direct sunlight.
- ▶ A pulsating direct voltage (rectified alternating voltage without smoothing) must not be used as the operating voltage.
- ▶ Use according to the authorized data, operating conditions, and conditions of use specified in the contract documents and operating instructions in chapter [“System description”](#) - [“10. Technical data”](#) in these instructions and the valve instructions for the respective pneumatically actuated valve.
- ▶ Use the device only in conjunction with third-party devices and components recommended and authorized by Bürkert.
- ▶ In view of the wide range of possible application cases, check whether the device is suitable for the specific application case and check this out if required.
- ▶ Correct transportation, storage and installation as well as careful operation and maintenance are essential for reliable and fault-free operation.
- ▶ Use Types 8792 and 8793 only as intended.



### 3 BASIC SAFETY INSTRUCTIONS

These safety instructions do not consider any contingencies or incidents which occur during assembly, operation and maintenance.

The operator is responsible for observing the location-specific safety regulations, also with reference to the personnel.



#### Danger – high pressure!

- ▶ Before loosening lines and valves, turn off the pressure and vent the lines.

#### Risk of electric shock.

- ▶ Before reaching into the device or the equipment, switch off the power supply and secure to prevent reactivation.
- ▶ Observe applicable accident prevention and safety regulations for electrical equipment.

#### Risk of burns/risk of fire during continuous operation through hot device surface.

- ▶ Keep the device away from highly flammable substances and media and do not touch with bare hands.

#### General hazardous situations.

To prevent injuries:

- ▶ Ensure that the system cannot be activated unintentionally.
- ▶ Installation and maintenance work may only be carried out by authorized specialist personnel and using the appropriate tools.
- ▶ After an interruption in the electrical or pneumatic supply, ensure that the process is restarted in a defined or controlled manner.
- ▶ The device may only be operated when in perfect condition and in consideration of the operating instructions.
- ▶ Do not supply the pressure supply connection of the system with aggressive or flammable media or any liquids.
- ▶ Do not physically stress the housing (e.g. by placing objects on it or standing on it).
- ▶ Do not make any external modifications to the device housings. Do not paint housing parts or screws.
- ▶ The general rules of technology must be observed for application planning and operation of the device.

#### NOTE

##### Electrostatic sensitive components / modules.

The device contains electronic components that are susceptible to electrostatic discharging (ESD). Components that come into contact with electrostatically charged people or objects are at risk. In the worst case scenario, these components are destroyed immediately or fail after start-up.

- ▶ Meet the requirements specified by EN 61340-5-1 to minimize or avoid the possibility of damage caused by sudden electrostatic discharge.
- ▶ Do not touch electronic components when the supply voltage is connected.



Failure to observe these operating instructions and the information contained therein as well as unauthorized tampering with the device release us from any liability and also invalidate the warranty covering the devices and accessories.

## 4 GENERAL INFORMATION

### 4.1 Contact addresses

#### Germany

Bürkert Fluid Control System  
Sales Center  
Chr.-Bürkert-Str. 13-17  
D-74653 Ingelfingen  
Phone + 49 (0) 7940 - 10 91 111  
Fax + 49 (0) 7940 - 10 91 448  
E-mail: [info@burkert.com](mailto:info@burkert.com)

#### International

Contact addresses can be found on the final pages of the printed brief instructions (Quickstart).

And also on the Internet at: [www.burkert.com](http://www.burkert.com)

### 4.2 Warranty

The warranty is only valid if the device is used as intended in accordance with the specified condition of use.

### 4.3 Master code

Operation of the device can be locked via a freely selectable user code. In addition, there is a non-changeable master code with which you can perform all operator actions on the device. This 4-digit master code can be found on the last pages of the printed brief instructions which are enclosed with each device.

If required, cut out the code and keep it separate from these operating instructions.

### 4.4 Information on the Internet

The operating instructions and data sheets for Types 8792 and 8793 can be found on the Internet at: [www.buerkert.de](http://www.buerkert.de)

## 5 PRODUCT DESCRIPTION

### 5.1 General description

The positioner Type 8792 / process controller Type 8793 is a digital, electro-pneumatic position controller for pneumatically actuated continuous valves. The device incorporates the main function groups

- Position sensor
- Electro-pneumatic actuating system
- Microprocessor electronics

The position sensor measures the current positions of the continuous valve.

The microprocessor electronics continuously compare the current position (actual value) with a position set-point value specified via the standard signal input and supplies the result to the positioner.

If there is a control difference, the electro-pneumatic actuating system corrects the actual position accordingly.

### 5.2 Properties

- **Variants**
  - Positioner (position controller) Type 8792
  - Process controller with integrated position controller, Type 8793.
- **Position sensor**
  - internal conductive plastic potentiometer with high resolution or
  - external non-contacting non-wearing position sensor (remote).
- **Microprocessor-controlled electronics**  
for signal processing, control and valve control.
- **Control module**  
The device is operated by 4 keys. The 128 x 64 dot matrix graphics display enables you to display the set-point value or actual value and to configure and parameterize via menu functions.
- **Actuating system**  
The actuating system consists of 2 solenoid valves and 4 diaphragm boosters. In single-acting actuators the working connection 2 must be sealed with a threaded plug.
- **Feedback (optional)**  
Feedback is either via 2 proximity switches (initiators), binary outputs or via an output (4...20 mA / 0...10 V). When the valve reaches an upper or lower position, this position can be relayed e.g. to a PLC via binary outputs. The operator can change the initiators or limit positions via control lugs.
- **Pneumatic interfaces**  
Internal thread G1/4"
- **Electrical interfaces**  
Circular plug-in connector or cable gland
- **Housing**  
Plastic coated aluminum housing with hinged cover and captive screws.
- **Attachment**  
to a linear actuator according to recommendation given by NAMUR (DIN IEC 534-6) or to a rotary actuator according to VDI/VDE 3845.
- **Optional**  
Remote variant for DIN rail mounting or mounting bracket.

## 5.2.1 Combination with valve types and mounting versions

The positioner Type 8792 / process controller Type 8793 can be mounted on different continuous valves. For example on valves with piston, membrane or rotary actuator. The actuators can be single-acting or double-acting.

- For single-acting actuators, only one chamber is aerated and deaerated during actuation. The generated pressure works against a spring. The piston moves until there is an equilibrium of forces between compressive force and spring force. To do this, one of the two air connections must be sealed with a threaded plug.
- For double-acting actuators the chambers on both sides of the piston are pressurized. In this case, one chamber is aerated when the other one is deaerated and vice versa. In this variant, no spring is installed in the actuator.

Two basic device variants are available for positioner Type 8792 / process controller Type 8793. They differ as to the mounting options and the position sensor.

### **NAMUR device variant:**

An internal position sensor is used which is designed as a rotary potentiometer. Type 8792/8793 is mounted directly on the actuator or attached to the side.

### **Remote device variant:**

An external position sensor (linear or rotary) is connected via an interface. Type 8792/8793 is attached to a wall either with a standard rail or with a mounting bracket (remote variant).

### 5.2.2 Overview of the mounting options

<p>Attachment of NAMUR on rotary actuator</p>	
<p>Attachment of NAMUR with a mounting bracket on a linear actuator</p>	
<p>Remote mounting with mounting bracket</p>	
<p>Remote mounting with DIN rail</p>	

MAN 1000341264 EN Version: C Status: RL (released | freigegeben) printed: 09.12.2019

Table 1: Overview of the mounting options

## 5.3 Variants

### 5.3.1 Type 8792, positioner

The position of the actuator is controlled according to the position set-point value. The position set-point value is specified by an external standard signal (or via fieldbus).

### 5.3.2 Type 8793, process controller

Type 8793 also features a PID controller which, apart from actual position control, can also be used to implement process control (e.g. level, pressure, flow rate, temperature) in the sense of a cascade control.

The process controller Type 8793 is operated with a 128 x 64 dot matrix graphics display and a keypad with 4 keys.

The process controller is linked to a control circuit. The set-point position of the valve is calculated from the process set-point value and the process actual value via the control parameters (PID controller). The process set-point value can be specified by an external signal.

### 5.3.3 Type 8793, remote variant



Depending on the connection variant type of the position sensor, Type 8793 functions as a

- Process controller or
- Positioner (position controller)

The following connection variants are available:

Function Type 8793	Interface	Position sensor	Setting in the menu ( <i>ADD.FUNCTION</i> )
Process controller	digital (serial)	Remote sensor Type 8798	<i>POS.SENSOR</i> → <i>DIGITAL</i> For menu description see chapter <a href="#">“16.1.21 POS.SENSOR”</a> on page 118
Positioner (position controller)	analog (4...20 mA) *	any high-resolution position sensor	<i>POS.SENSOR</i> → <i>ANALOG</i> For menu description see chapter <a href="#">“16.1.21 POS.SENSOR”</a> on page 118

Table 2: Connection variants Type 8793 with external position sensor



\* If the external position sensor is connected to the process controller Type 8793 via the analog interface, it can be operated only as a positioner (position controller).

The options for connection of an external position sensor are described in chapter [“11.4 Remote operation with external position sensor”](#) on page 38.

## 6 STRUCTURE AND FUNCTION

The positioner Type 8792 and process controller Type 8793 consist of the micro-processor controlled electronics, the position sensor and the actuating system.

The device is designed using three-wire technology. Operation is controlled by four keys and a 128x64 dot matrix graphics display.

The pneumatic actuating system for single-acting and double-acting actuators consists of 2 solenoid valves.

### 6.1 Representation

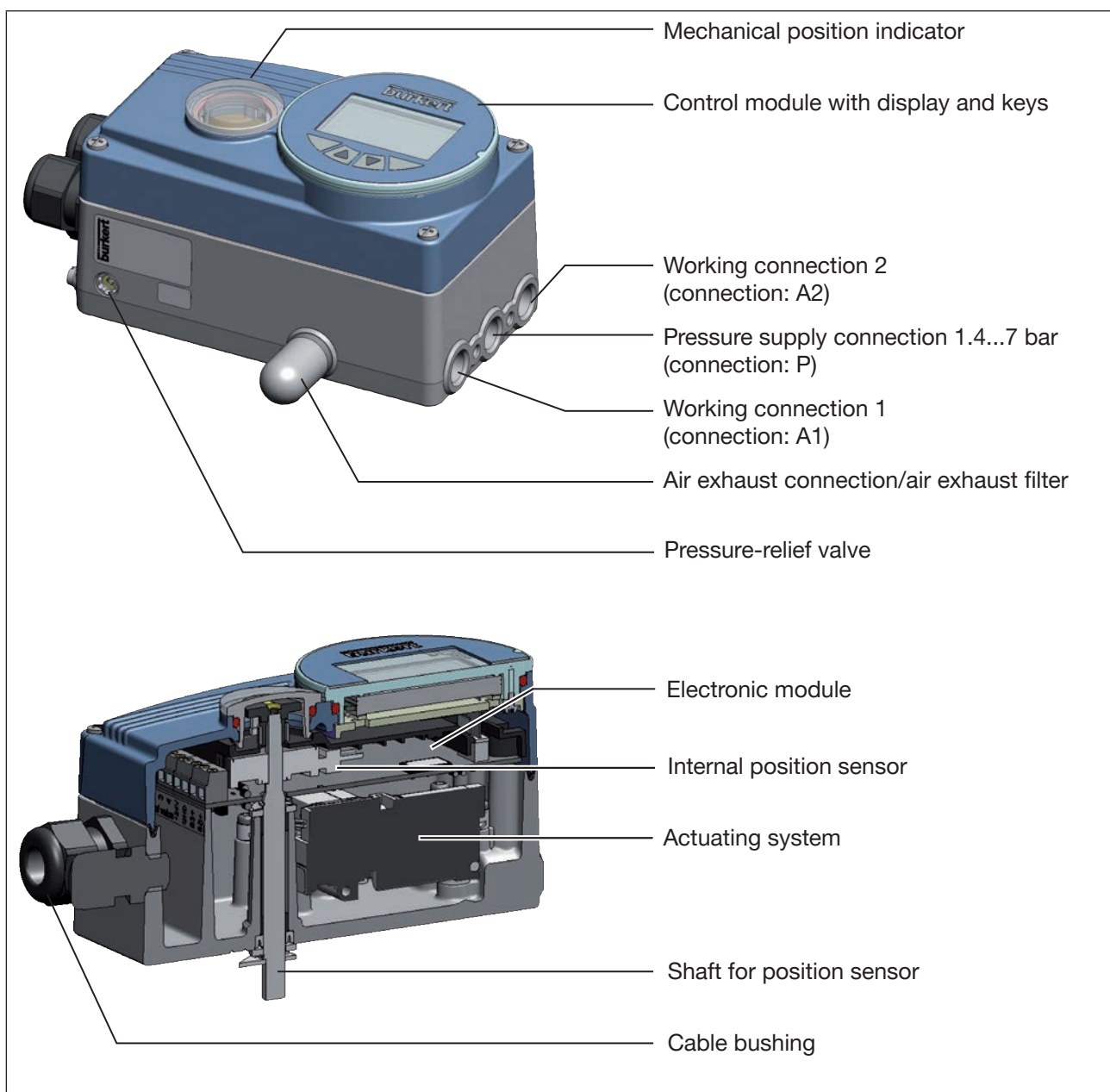


Figure 1: Structure, Type 8792/8793

## 6.2 Function diagram

### 6.2.1 Diagram illustrating single-acting actuator

The black lines in “Figure 2” describe the function of the position controller circuit in Type 8792.

The gray part of the diagram indicates the additional function of the superimposed process control circuit in Type 8793.

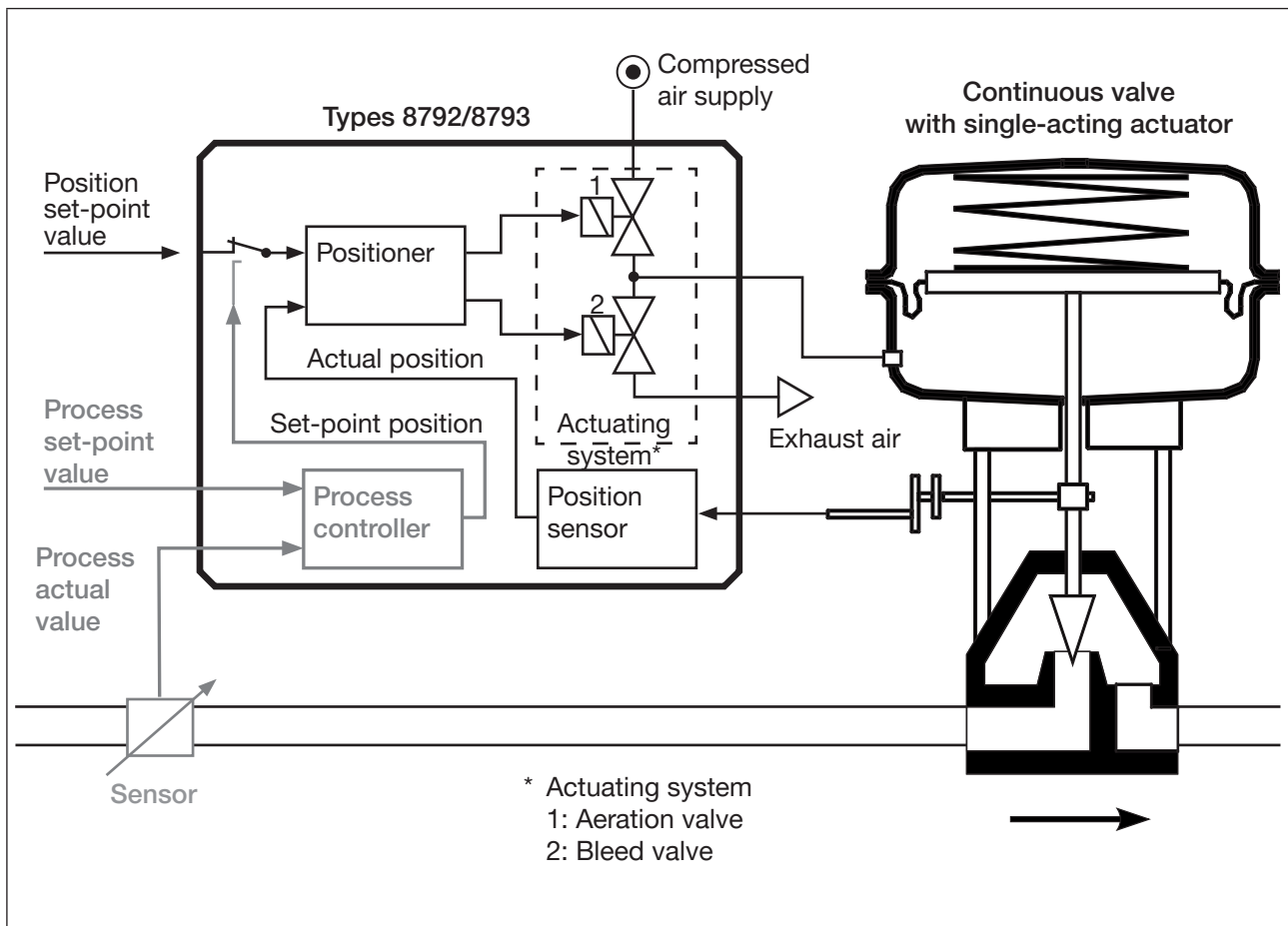


Figure 2: Structure, positioner Type 8792 / process controller Type 8793

**!** The remote variant has the position sensor situated outside the device directly on the continuous valve and is connected to the latter by a cable.



## 7 POSITIONER TYPE 8792

The position sensor records the current position (*POS*) of the pneumatic actuator. The positioner compares this position actual value with the set-point value (*CMD*) which is specified as a standard signal. If there is a control difference (*Xd1*), the actuator is aerated and de-aerated via the actuating system. In this way the position of the actuator is changed until control difference is 0. *Z1* represents a disturbance variable.

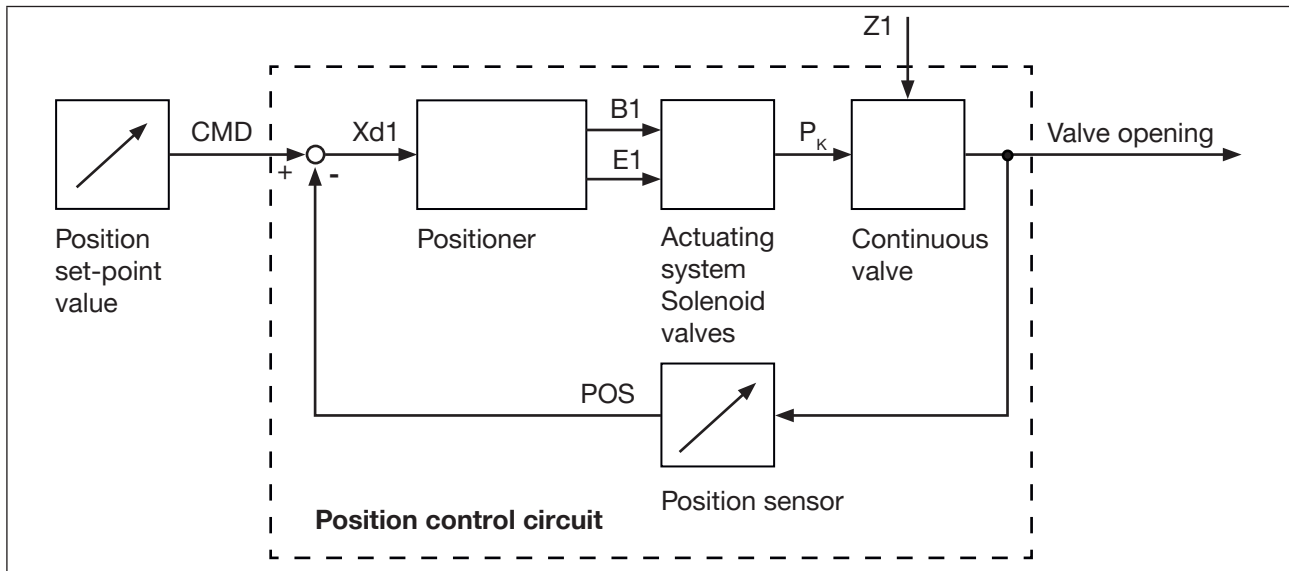


Figure 3: Position control circuit in Type 8792

## 7.1 Schematic representation of the position control

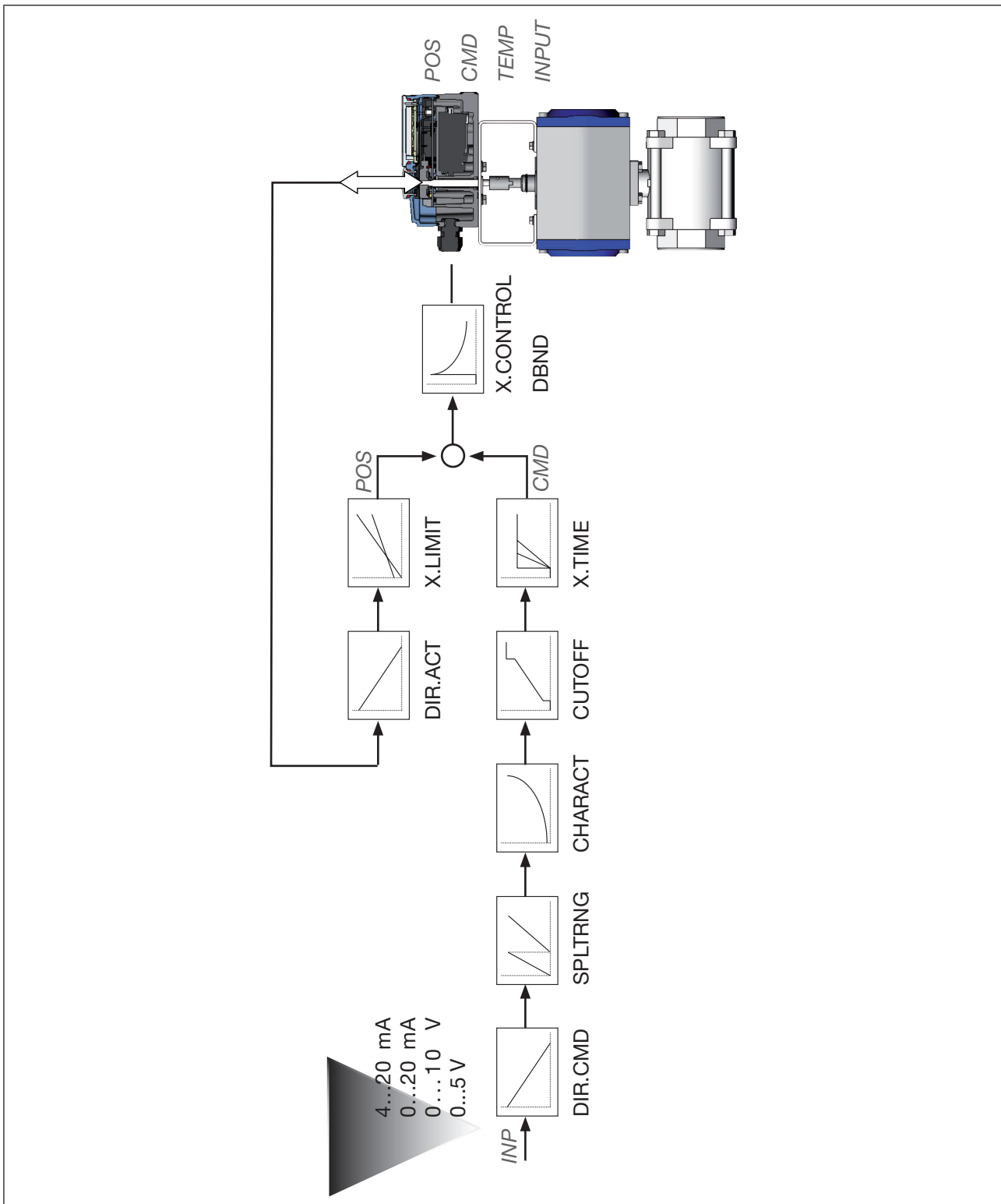


Figure 4: Schematic representation of position control

## 7.2 The positioner software

Configurable auxiliary functions	Effect
Correction line to adjust the operating characteristic <i>CHARACT</i>	Selection of the transfer characteristic between input signal and stroke (correction characteristic).
Sealing function <i>CUTOFF</i>	Valve closes tight outside the control range. Specification of the value (as%), from which the actuator is completely de-aerated (when 0%) or aerated (when 100%).
Effective direction of the controller set-point value <i>DIR.CMD</i>	Effective direction between input signal and set-point position.
Effective direction of the actuating drive <i>DIR.ACT</i>	Adjustment of the effective direction between aeration state of the actuator and the actual position.
Signal split range <i>SPLTRNG</i>	Splitting of the standard signal range to two or more positioners.
Stroke limit <i>X.LIMIT</i>	Mechanical valve piston movement only within a defined stroke range.
Limit of the control speed <i>X.TIME</i>	Input of the opening and closing time for the total stroke.
Insensitivity range <i>X.CONTROL</i>	The positioner is initially actuated from a control difference to be defined.
Code protection <i>SECURITY</i>	Code protection for settings.
Safety position <i>SAFEPOS</i>	Definition of the safety position.
Signal level fault detection <i>SIG.ERROR</i>	Check the input signals for sensor break. Warning output on the display and approaching the safety position (if selected).
Binary input <i>BINARY. IN</i>	Switching between AUTOMATIC / MANU or approaching the safety position.
Analogue feedback (option) <i>OUTPUT</i>	Feedback set-point value or actual value.
2 binary outputs (option) <i>OUTPUT</i>	Output of two selectable binary values.
User calibration <i>CAL.USER</i>	Change to the factory calibration of the signal input.
Factory settings <i>SET.FACTORY</i>	Reset to factory settings.

Configurable auxiliary functions	Effect
Serial interface <i>SER.I/O</i>	Configuration of serial interface.
Setting display <i>EXTRAS</i>	Adjustment of the display of the process level.
<i>SERVICE</i>	For internal use only.
<i>POS.SENSOR</i>	Setting interface remote position sensor (available for Type 8793 Remote only). See chapter <a href="#">“5.3.3 Type 8793, remote variant”</a> on page 14
Simulation software <i>SIMULATION</i>	For simulation of the device functions.
<i>DIAGNOSE (option)</i>	Monitoring of processes.

Table 3: Positioner software. Configurable auxiliary functions

Hierarchical operating concept for easy operation on the following operating levels	
Process level	On the process level you switch between the AUTOMATIC and MANU operating states.
Setting level	On the setting level specify certain basic functions during start-up and configure auxiliary functions if required.

Table 4: The positioner software. Hierarchical operating concept.

## 8 PROCESS CONTROLLER TYPE 8793

In the case of process controller Type 8793 the position control mentioned in chapter “7” becomes the subordinate auxiliary control circuit; this results in a cascade control. The process controller in the main control circuit of Type 8793 has a PID function. The process set-point value ( $SP$ ) is specified as set-point value and compared with the actual value ( $PV$ ) of the process variable to be controlled. The position sensor records the current position ( $POS$ ) of the pneumatic actuator. The positioner compares this position actual value with the set-point value ( $CMD$ ) which is specified by the process controller. If there is a control difference ( $Xd1$ ), the actuator is aerated and de-aerated via the actuating system. In this way the position of the actuator is changed until control difference is 0.  $Z2$  represents a disturbance variable.

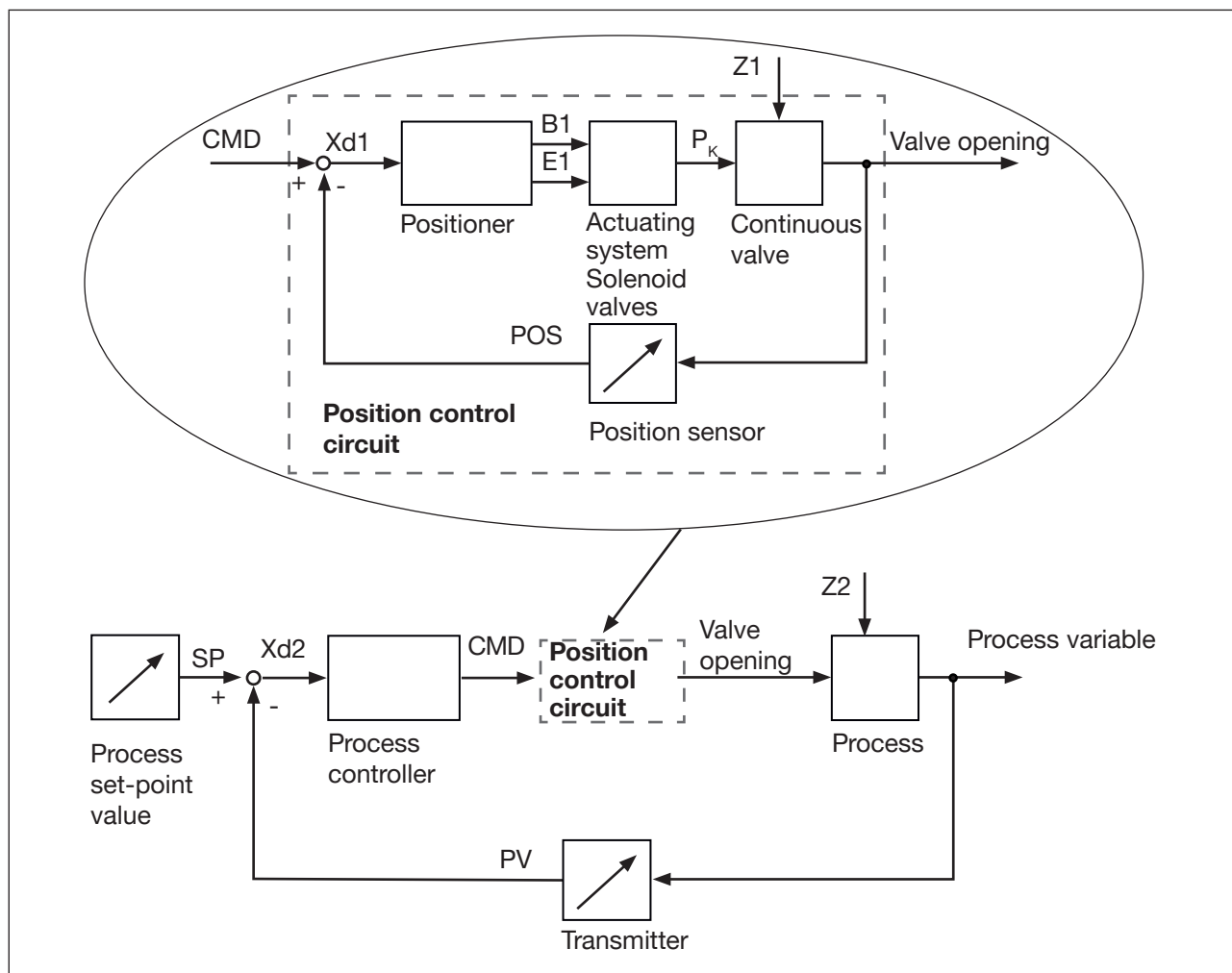


Figure 5: Signal flow plan of process controller

MAN 1000341264 EN Version: C Status: RL (released | freigegeben) printed: 09.12.2019

## 8.1 Schematic representation of process control

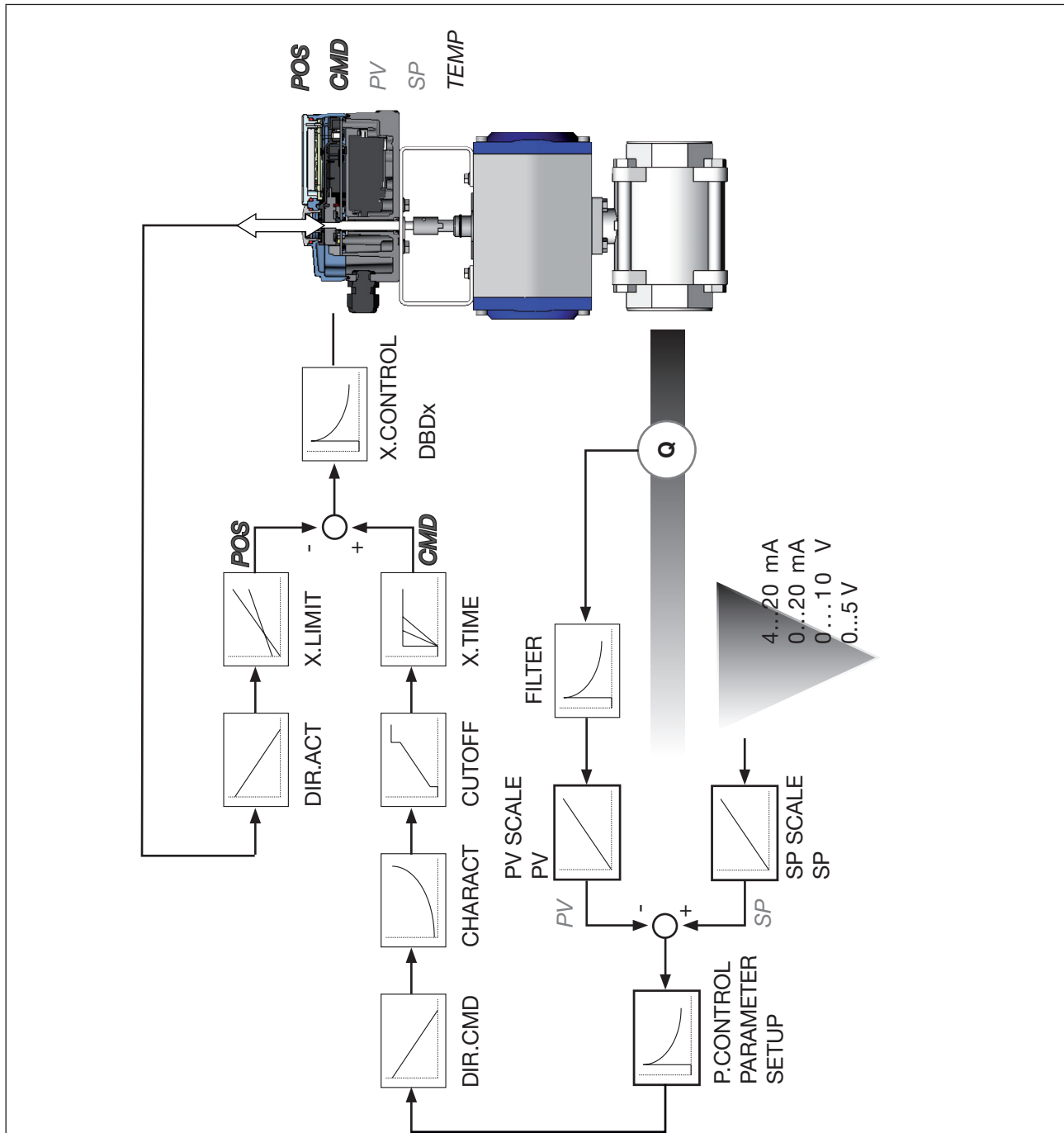


Figure 6: Schematic representation of process control

## 8.2 The process controller software

Configurable auxiliary functions	Effect
Correction line to adjust the operating characteristic <i>CHARACT</i>	Selection of the transfer characteristic between input signal and stroke (correction characteristic).
Sealing function <i>CUTOFF</i>	Valve closes tight outside the control range. Specification of the value (as%), from which the actuator is completely de-aerated (when 0%) or aerated (when 100%).
Effective direction of the controller set-point value <i>DIR.CMD</i>	Effective direction between input signal and set-point position.
Effective direction of the actuating drive <i>DIR.ACT</i>	Adjustment of the effective direction between aeration state of the actuator and the actual position.
Signal split range <i>SPLTRNG</i>	Splitting of the standard signal range to two or more positioners.
Stroke limit <i>X.LIMIT</i>	Mechanical valve piston movement only within a defined stroke range.
Limit of the control speed <i>X.TIME</i>	Input of the opening and closing time for the entire stroke.
Insensitivity range <i>X.CONTROL</i>	The positioner is initially actuated from a control difference to be defined.
Code protection <i>SECURITY</i>	Code protection for settings.
Safety position <i>SAFEPOS</i>	Definition of the safety position.
Signal level fault detection <i>SIG.ERROR</i>	Check the input signals for sensor break. Warning output on the display and approaching the safety position (if selected).
Binary input <i>BINARY. IN</i>	Switching between AUTOMATIC / MANU or approaching the safety position.
Analogue feedback (option) <i>OUTPUT</i>	Feedback set-point value or actual value.
2 binary outputs (option) <i>OUTPUT</i>	Output of two selectable binary values.
User calibration <i>CAL.USER</i>	Change to the factory calibration of the signal input.
Factory settings <i>SET.FACTORY</i>	Reset to factory settings.
Serial interface <i>SER.I/O</i>	Configuration of serial interface.

Configurable auxiliary functions	Effect
Setting display <i>EXTRAS</i>	Adjustment of the display of the process level.
<i>SERVICE</i>	For internal use only.
<i>POS.SENSOR</i>	Setting interface remote position sensor (available for Type 8793 Remote only). See chapter <a href="#">“5.3.3 Type 8793, remote variant”</a> on page 14
Simulation software <i>SIMULATION</i>	For simulation of the device functions.
<i>DIAGNOSE (option)</i>	Monitoring of processes.

Table 5: The process controller software. Configurable auxiliary functions of the position controller

Functions and setting options of the process controller	
Process controller <i>P.CONTROL</i>	PID process controller is activated.
Adjustable parameters <i>P.CONTROL - PARAMETER</i>	Parameterization of the process controller Proportional coefficient, reset time, hold-back time and operating point.
Scalable inputs <i>P.CONTROL - SETUP</i>	Configuration of the process controller - Selection of the sensor input - Scaling of process actual value and process set-point value - Selection of the set-point value defaults.
<i>Automatic sensor detection or manual sensor setting</i> <i>P.CONTROL - SETUP - PV INPUT</i>	Sensor types Pt 100 and 4...20 mA are automatically detected or can be manually set via the operating menu.
Selection of the set-point value default <i>P.CONTROL - SETUP - SP INPUT</i>	Set-point value default either via standard signal input or via keys.
<i>Process characteristic linearization</i> <i>P.Q'LIN</i>	Function for the automatic linearization of the process characteristics.
<i>Process controller optimization</i> <i>P.TUNE</i>	Function for automatic optimization of the process controller parameters.

Table 6: The process controller software. Functions and setting options of the process controller

Hierarchical operating concept for easy operation on the following operating levels	
Process level	On the process level you switch between the AUTOMATIC and MANU operating states.
Setting level	On the setting level specify certain basic functions during start-up and configure auxiliary functions if required.

Table 7: The process controller software. Hierarchical operating concept



## 9 INTERFACES

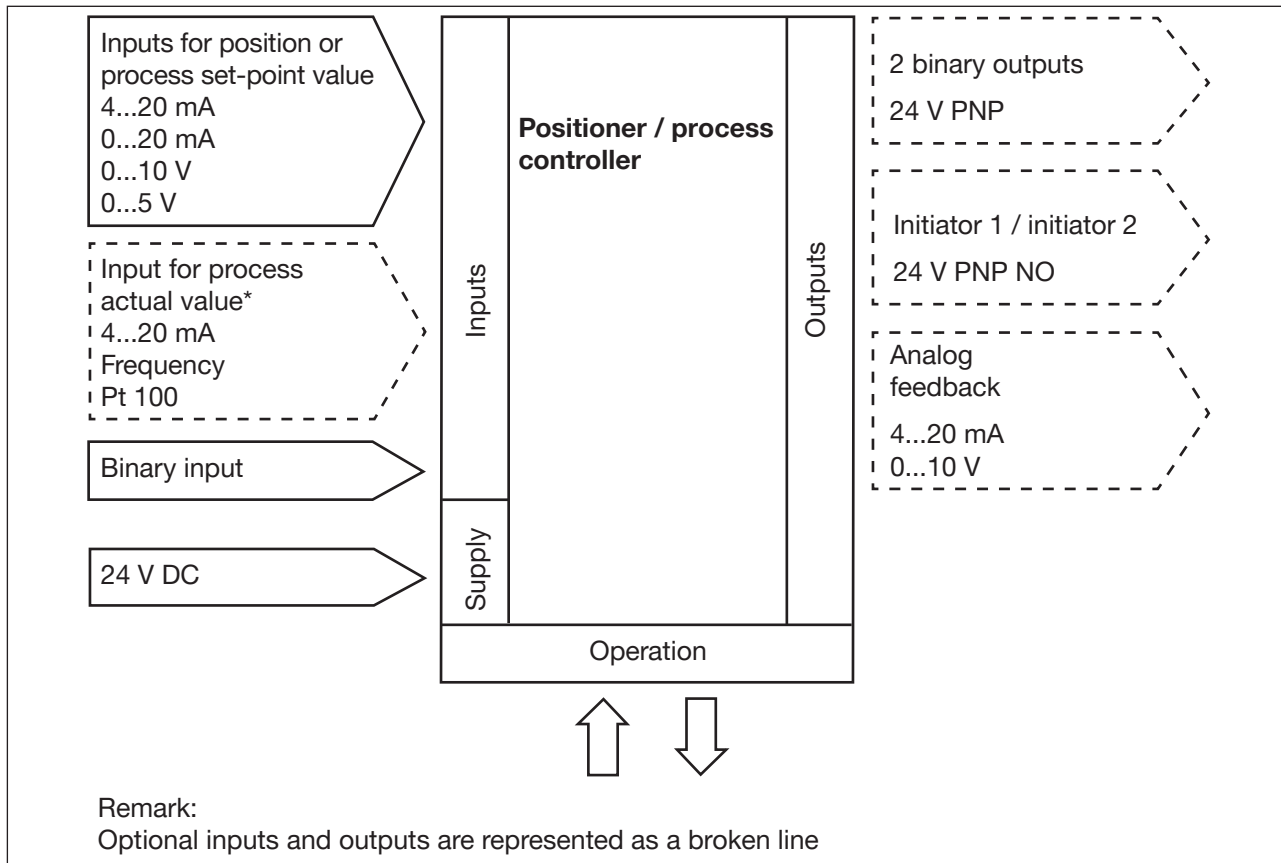


Figure 7: Interfaces of the positioner / process controller

**!** Types 8792 and 8793 are 3-wire devices, i.e. the power (24 V DC) is supplied separately from the set-point value signal.

\* only for process controller Type 8793

## 10 TECHNICAL DATA

### 10.1 Conformity

Type 8792, 8793 complies with the EC directives according to the EC Declaration of Conformity (if applicable).

### 10.2 Standards

The applied standards, which are used to demonstrate compliance with the EC Directives, are listed in the EC Prototype Examination Certificate and/or the EC Declaration of Conformity (if applicable).

### 10.3 Approvals

The product is approved for use in zone 2 and 22 in accordance with ATEX directive 2014/34/EU category 3GD.



Observe instructions on operation in potentially explosive atmospheres. See supplementary ATEX instructions.

### 10.4 Operating conditions



#### WARNING

Solar radiation and temperature fluctuations may cause malfunctions or leaks.

- ▶ If the device is used outdoors, do not expose it unprotected to the weather conditions.
- ▶ The permitted ambient temperature may not exceed the maximum value or drop below the minimum value.

Ambient temperature      -10...+60 °C

Degree of protection      IP 65 / IP 67\* according to EN 60529  
(only if cables and plugs and sockets connected correctly)

\* If the positioner is used under IP 67 conditions, the ventilation filter (see [“Figure 1: Structure, Type 8792/8793”](#)) must be removed and the exhaust air conveyed to the dry area.

## 10.5 Type label

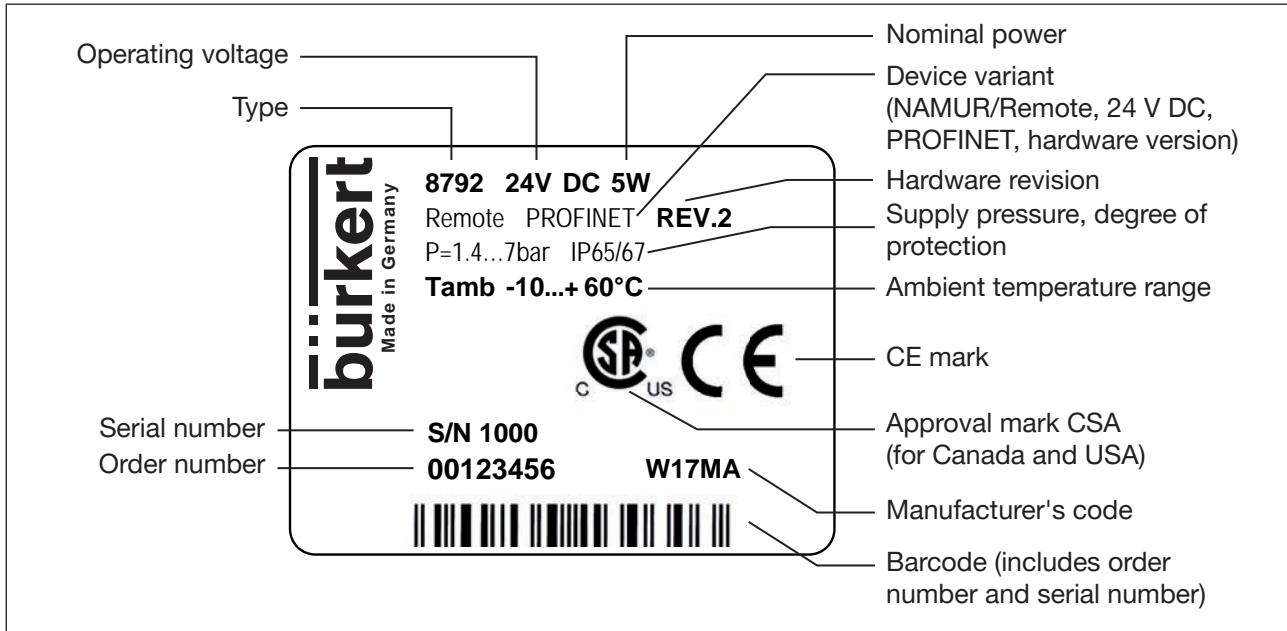


Figure 8: Example of type label

## 10.6 Mechanical data

Dimensions	see data sheet
Material	
Housing material	plastic-coated aluminum
Other external parts	stainless steel (V4A), PC, PE, POM, PTFE
Seal material	EPDM, NBR, FKM
Mass	approx. 1.0 kg

## 10.7 Electrical data

Connections	2 cable bushings (M20 x 1.5) with screw-type terminals 0.14...1.5 mm <sup>2</sup> or circular plug-in connector	
Operating voltage	24 V DC ±10% max. residual ripple 10%	
Power consumption	< 5 W	
Input data for actual value signal		
4...20 mA:	Input resistance	70 Ω
	Resolution	12 bit
Frequency:	Measurement range	0...1000 Hz
	Input resistance	20 kΩ
	Resolution	1‰ of measurement value,
	Input signal	> 300 mV <sub>SS</sub>
	Waveform	Sine wave, square wave, triangle wave
Pt 100:	Measurement range	-20 to +220 °C
	Resolution	< 0.1 °C
	Measurement current	< 1 mA
Input data for set-point value signal		
0/4...20 mA:	Input resistance	70 Ω
	Resolution	12 bit
0...5/10 V:	Input resistance	20 kΩ at 0...5 V only 11 bit
	Resolution	12 bit
Protection class	III according to DIN EN 61140 (VDE 0140-1)	
Analog feedback		
max. current	10 mA (for voltage output 0...5/10 V)	
Load	0...560 Ω (for current output 0/4...20 mA)	
Inductive proximity switches	100 mA current limitation	
Binary outputs	galvanically isolated, PNP	
Current limitation	100 mA, output is clocked if overload occurs	
Binary input	PNP	
	0...5 V = log "0", 10...30 V = log "1"	
	inverted input reversed accordingly (input current < 6 mA)	
Communications interface	Connection to PC with USB bÜS interface set Communication with Bürkert-Communicator	
Communication software	Bürkert-Communicator (see "Accessories")	

## 10.8 Pneumatic data

Control medium	Air, neutral gases Quality classes in accordance with ISO 8573-1
Dust content	Class 7, max. particle size 40 µm, max. particle density 10 mg/m <sup>3</sup>
Water content	Class 3, max. pressure dew point -20 °C or min. 10 degrees below the lowest operating temperature
Oil content	Class X, max. 25 mg/m <sup>3</sup>
Temperature range of compressed air	0...+60 °C
Pressure range	1.4...7 bar
Air flow rate	50 I <sub>N</sub> / min (at 1.4 bar*) for aeration and de-aeration 150 I <sub>N</sub> / min (at 6 bar*) for aeration and de-aeration (Q <sub>Nn</sub> = 100 I <sub>N</sub> / min (according to definition for pressure drop from 7 to 6 bar absolute)).
Connections	Internal threads G1/4"

---

\* Pressure specifications: Overpressure with respect to atmospheric pressure

## 10.9 Safety end positions after failure of the electrical or pneumatic auxiliary power

The safety end position depends on the pneumatic connection of the actuator to the working connections A1 or A2.

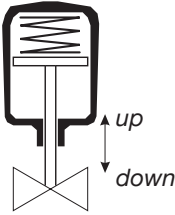
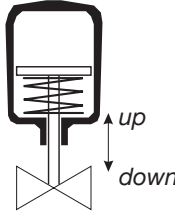
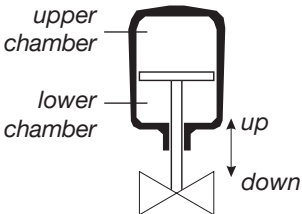
Type of actuator	Designation	Safety end positions after failure of the auxiliary power	pneumatic auxiliary power
	single-acting Control function A	down → Connection according to <a href="#">“Figure 9”</a>	down
		up → Connection according to <a href="#">“Figure 10”</a>	
	single-acting Control function B	up → Connection according to <a href="#">“Figure 9”</a>	up
		down → Connection according to <a href="#">“Figure 10”</a>	
	double-acting Control function I	Connection according to <a href="#">“Figure 11”</a>	not defined
		up = lower chamber of the actuator to A2	
		down = upper chamber of the actuator to A2	

Table 8: Safety end positions

pneumatic connection: Description of [“Table 8”](#).

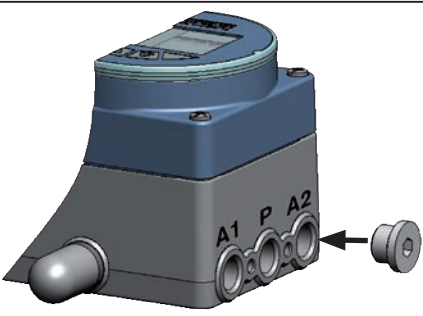
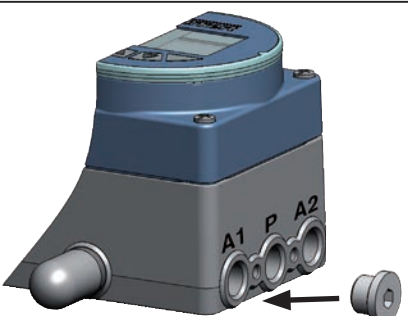
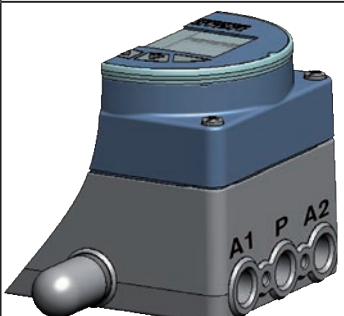
Single-acting actuators Control function A or B	Double-acting actuators Control function I
 <p>Connect working connection A1 to actuator Close A2</p>	 <p>Connect working connection A2 to actuator Close A1</p>
 <p>Connect working connection A1 and A2 to actuator Safety end position: up = lower chamber to A2 down = upper chamber to A2</p>	

Table 9: Pneumatic connection

# 11 ASSEMBLY



The dimensions of the positioner Type 8792/8793 and the different device variants can be found on the data sheet.

## 11.1 Safety instructions



### WARNING

Risk of injury due to incorrect assembly.

- ▶ Assembly may only be carried out by authorized specialist personnel and using the appropriate tools.

Risk of injury due to unintentional switching on of the plant and uncontrolled start-up.

- ▶ Secure the device against accidental activation.
- ▶ Following assembly, ensure a controlled restart.

## 11.2 Attachment to a continuous valve with linear actuator according to NAMUR

The valve position is transferred to the position sensor installed in the positioner via a lever (according to NAMUR).

### 11.2.1 Attachment kit to linear actuator (ident. No. 787 215)

(Can be purchased as an accessory from Bürkert).

Seq. No.	Quantity	Designation
1	1	NAMUR mounting bracket IEC 534
2	1	Hoop
3	2	Clamping piece
4	1	Driver pin
5	1	Conical roller
6a	1	NAMUR lever for stroke range 3 - 35 mm
6b	1	NAMUR lever for stroke range 35 - 130 mm
7	2	U-pin
8	4	Hexagon bolt DIN 933 M8 x 20
9	2	Hexagon bolt DIN 933 M8 x 16
10	6	Circlip DIN 127 A8
11	6	Washer DIN 125 B8.4
12	2	Washer DIN 125 B6.4
13	1	Spring VD-115E 0.70 x 11.3 x 32.7 x 3.5

Seq. No.	Quantity	Designation
14	1	Spring washer DIN 137 A6
15	1	Locking washer DIN 6799 - 3.2
16	3	Circlip DIN 127 A6
17	3	Hexagon bolt DIN 933 M6 x 25
18	1	Hexagon nut DIN 934 M6
19	1	Square nut DIN 557 M6
21	4	Hexagon nut DIN 934 M8
22	1	Guide washer 6.2 x 9.9 x 15 x 3.5

Table 10: Attachment kit on linear actuator

## 11.2.2 Assembly

### **! WARNING**

Risk of injury due to incorrect assembly.

- ▶ Assembly may only be carried out by authorized specialist personnel and using the appropriate tools.

Risk of injury due to unintentional switching on of the plant and uncontrolled start-up.

- ▶ Secure the device against accidental activation.
- ▶ Following assembly, ensure a controlled restart.

#### Procedure:

→ Mount hoop ② with the aid of the clamping elements ③, hexagon bolts ⑰ and circlips ⑱ on the actuator spindle.

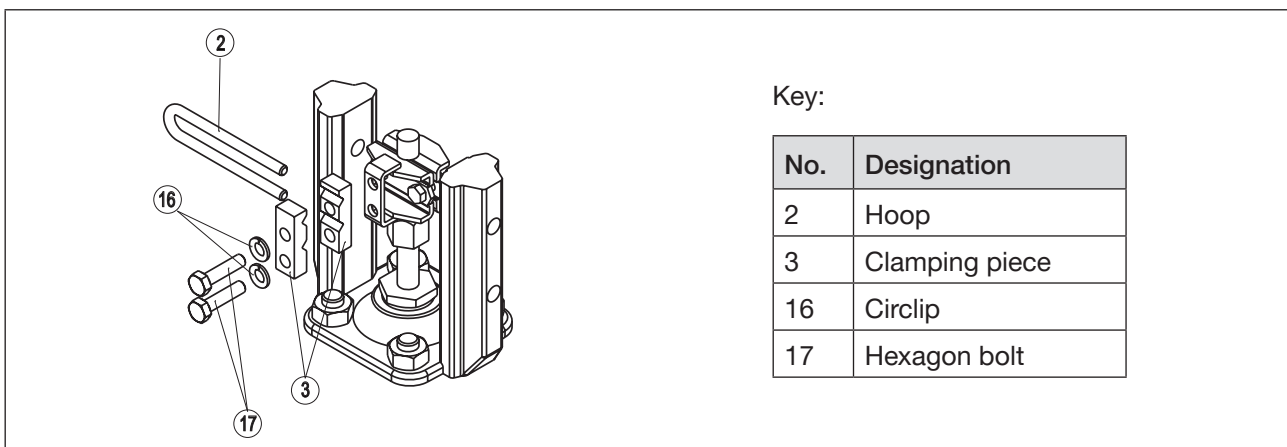


Figure 9: Assembling the hoop



→ Select short or long lever according to the stroke of the actuator [“Table 10: Attachment kit on linear actuator”](#).

→ Assemble lever (unless pre-assembled) (see [“Figure 10: Assembling the lever”](#)).

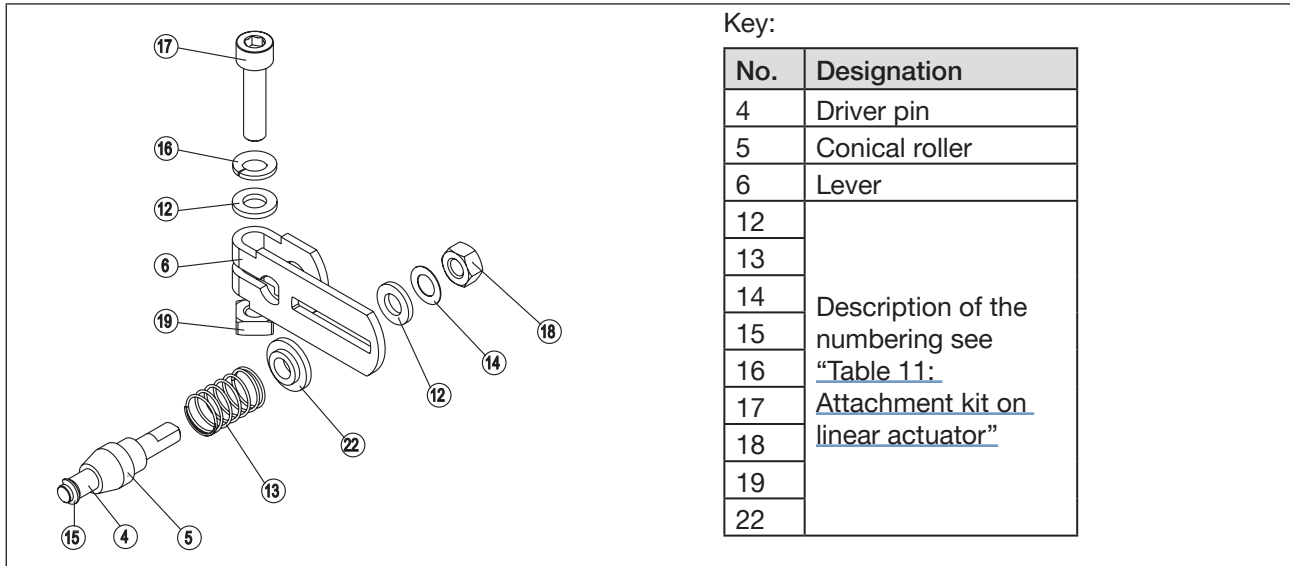


Figure 10: Assembling the lever

**!** The gap between the driver pin and the shaft should be the same as the actuator stroke. As a result, the lever has a swing range of 60° (see [“Figure 11: Swing range of the lever”](#)).

**Rotation range of the position sensor:**

The maximum rotation range of the position sensor is 180°.

**Swing range of the lever:**

To ensure that the position sensor operates at a good resolution, the swing range of the lever must be at least 30°.

The swing movement of the lever must be within the position sensor rotation range of 180°.

The scale printed on the lever is not relevant.

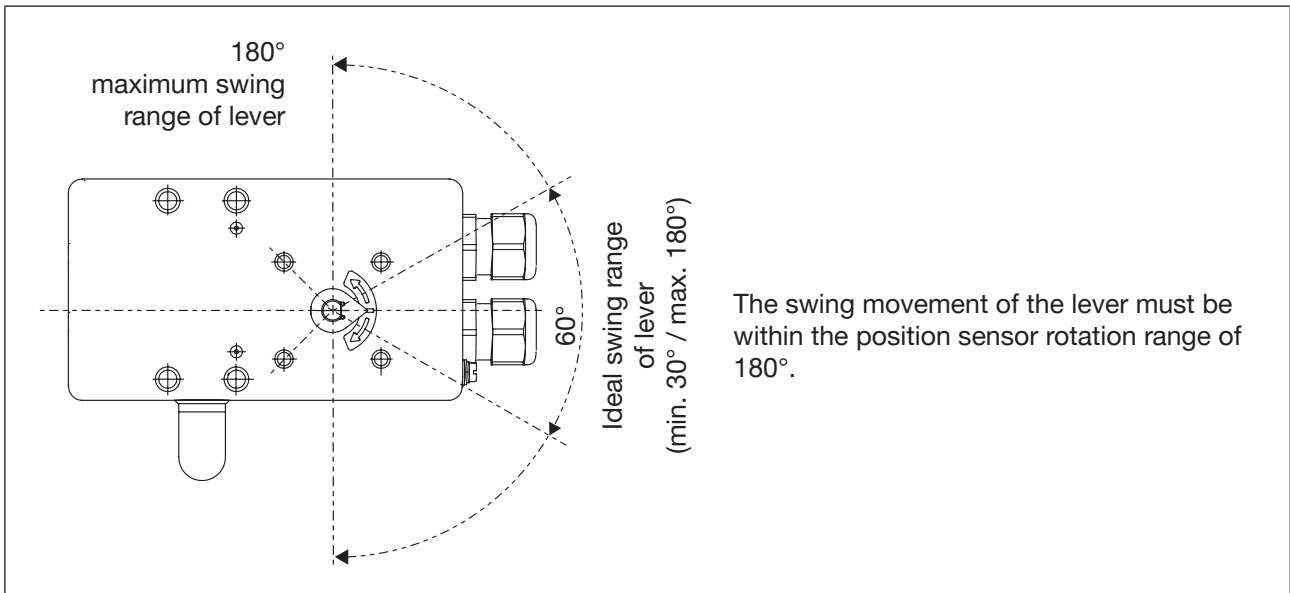


Figure 11: Swing range of the lever

→ Mount lever on the shaft of Type 8792/8793 and tighten.

### 11.2.3 Attaching the mounting bracket

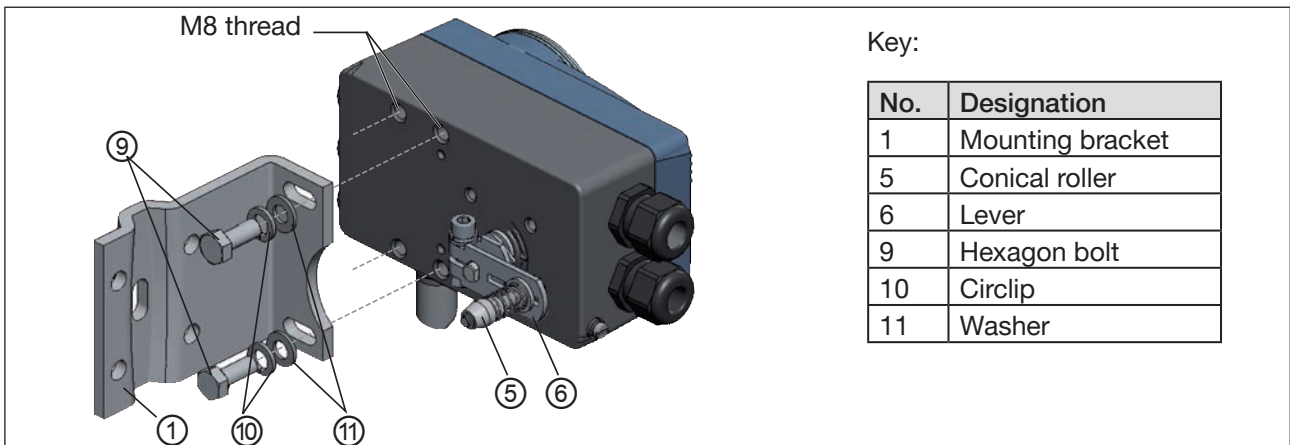
→ Attach mounting bracket ① with hexagon bolts ⑨, circlips ⑩ and washers ⑪ to the rear side of Type 8792/8793 (see “Figure 12: Attaching the mounting bracket”).



The selection of the M8 thread used on the positioner depends on the size of the actuator.

→ To determine the correct position, hold the positioner with mounting bracket on the actuator.

The conical roller on the lever of the position sensor must be able to move freely in the hoop (see “Figure 12: Attaching the mounting bracket”) along the entire stroke range of the actuator. The lever position should be almost horizontally when the stroke is 50% (see chapter “11.2.4 Aligning the lever mechanism”).



Key:

No.	Designation
1	Mounting bracket
5	Conical roller
6	Lever
9	Hexagon bolt
10	Circlip
11	Washer

Figure 12: Attaching the mounting bracket

**Attaching the Type 8792/8793 with mounting bracket for actuators with cast frame:**

→ Attach mounting bracket to the cast frame with one or more hexagon bolts (8), washers (11) and circlips (10) (see “Figure 13”).

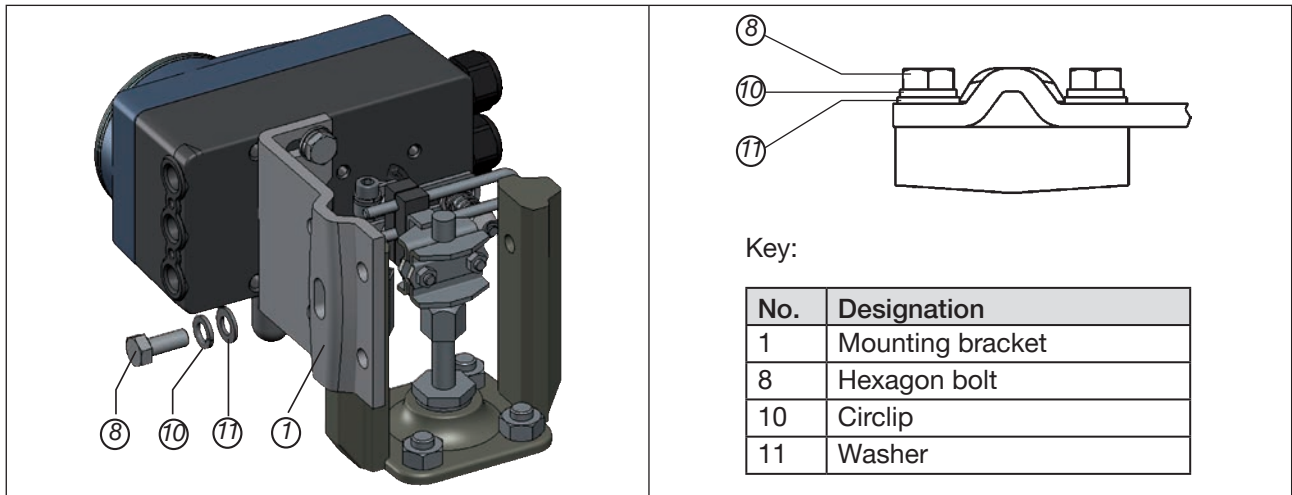


Figure 13: Attach positioner with mounting bracket; for actuators with cast frame

**Attaching the Type 8792/8793 with mounting bracket for actuators with columnar yoke:**

→ Attach mounting bracket to the columnar yoke (21) with the U-bolt (7), washers (11), circlips (10) and hexagon nuts (see “Figure 14”).

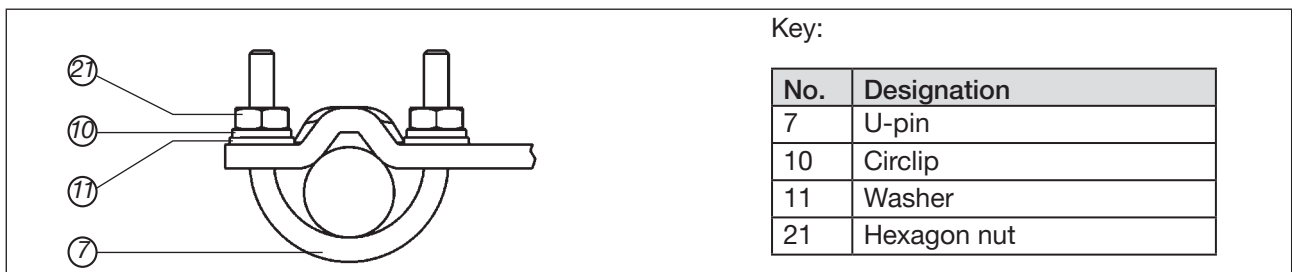


Figure 14: Attach positioner with mounting bracket; for actuators with columnar yoke

**11.2.4 Aligning the lever mechanism**

**!** The lever mechanism cannot be correctly aligned until the device has been connected electrically and pneumatically.

→ Move the actuator in operating state MANU to half stroke (according to the scale on the actuator).

→ Adjust the height of the positioner until the lever is horizontal.

→ Fix the positioner in this position on the actuator.

MAN 1000341264 EN Version: C Status: RL (released | freigegeben) printed: 09.12.2019

## 11.3 Attachment to a continuous valve with rotary actuator

The shaft of the position sensor integrated in the positioner is connected directly to the shaft of the rotary actuator.

### 11.3.1 Attachment kit (as per VDI/VDE 3845) on the rotary actuator (Ident. No. 787338).

(Can be purchased as an accessory from Bürkert).

Seq. No.	Quantity	Designation
1	1	Adapter
2	2	Setscrew DIN 913 M4 x 10
3	4	Hexagon bolt DIN 933 M6 x 12
4	4	Circlip B6
5	2	Hexagon nut DIN 985 M4

Table 11: Attachment kit on rotary actuator

#### Other accessories:

For the order number for the assembly bridge with fastening screws (as per VDI/VDE 3845), please refer to the data sheet for Type 8792/8793.

### 11.3.2 Assembly



#### WARNING

Risk of injury due to incorrect assembly.

- ▶ Assembly may only be carried out by authorized specialist personnel and using the appropriate tools.

Risk of injury due to unintentional switching on of the plant and uncontrolled start-up.

- ▶ Secure the device against accidental activation.
- ▶ Following assembly, ensure a controlled restart.

#### Procedure:

- Define the attachment position of Type 8792/8793:
  - in parallel to the actuator or
  - rotated by 90° to the actuator.
- Determine the home position and the direction of rotation of the actuator.
- Fit adaptor to the shaft of Type 8792/8793 and attach with 2 setscrews.

**! Anti-twist safeguard:**  
 Note the flat side of the shaft. One of the setscrews must be situated on the flat side of the shaft as an anti-twist safeguard (see "Figure 15").

**Rotation range of the position sensor:**  
 The maximum rotation range of the position sensor is 180°. The shaft of Type 8792/8793 may be moved within this range only.

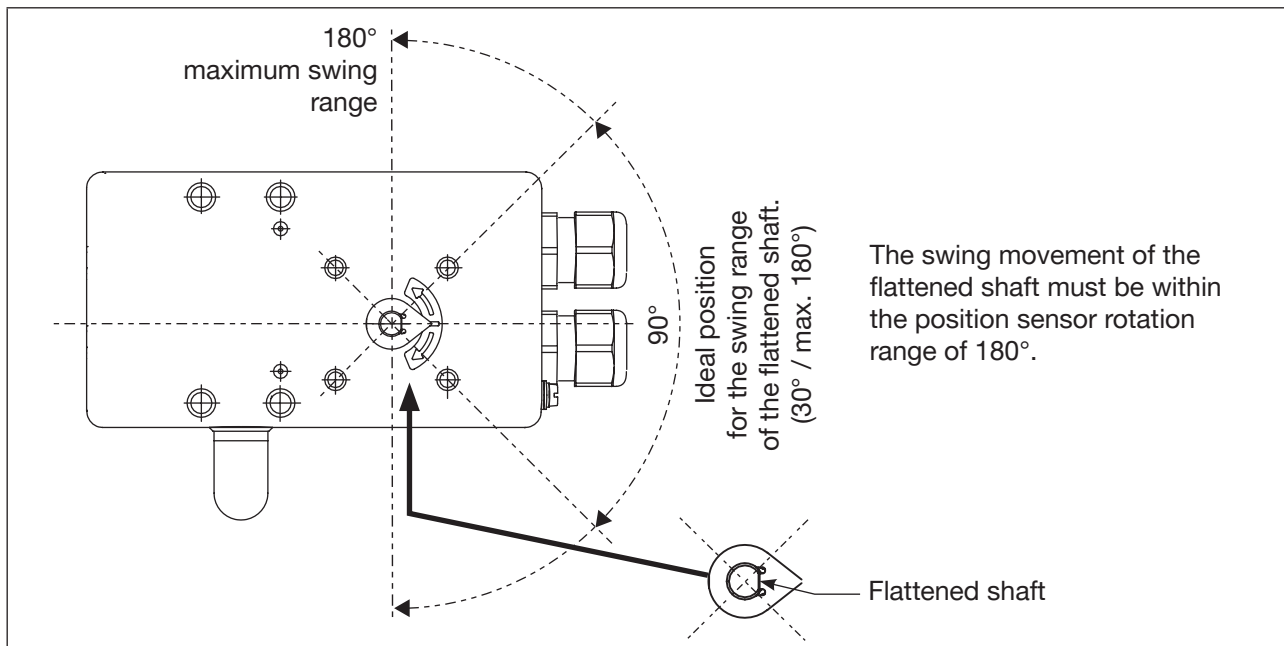


Figure 15: Rotation range / anti-twist safeguard

- Set up the multi-part assembly bridge\* to suit the actuator.
- Attach the assembly bridge by 4 hexagon bolt ③ and circlips ④ to Type 8792/8793 (see "Figure 16").

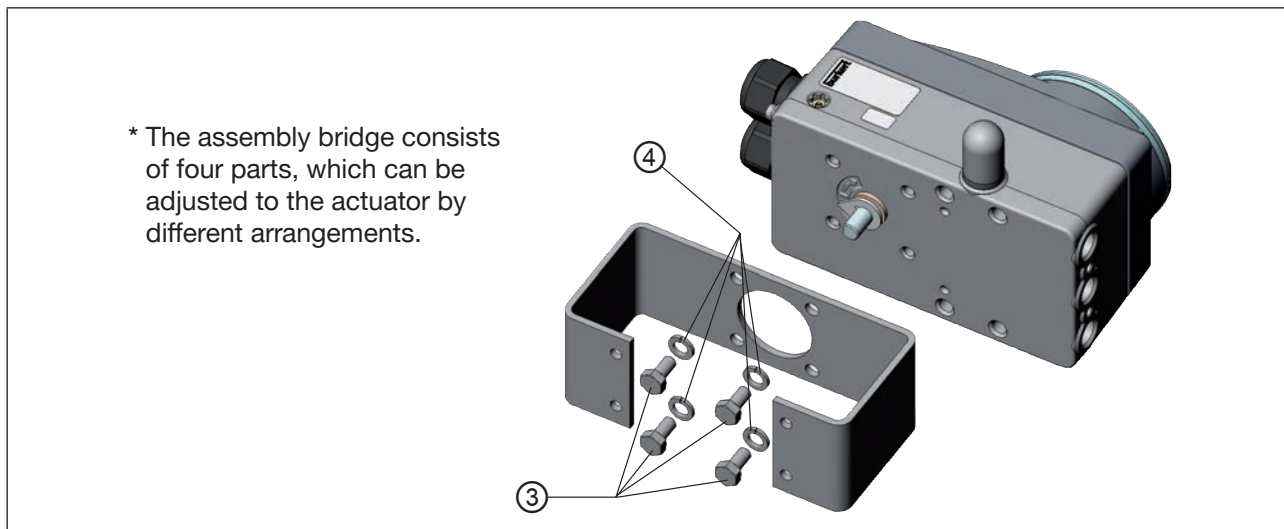


Figure 16: Attaching the assembly bridge (schematic representation)

MAN 1000341264 EN Version: C Status: RL (released | freigegeben) printed: 09.12.2019

→ Place Type 8792/8793 with assembly bridge on the rotary actuator and attach (see “Figure 17”).

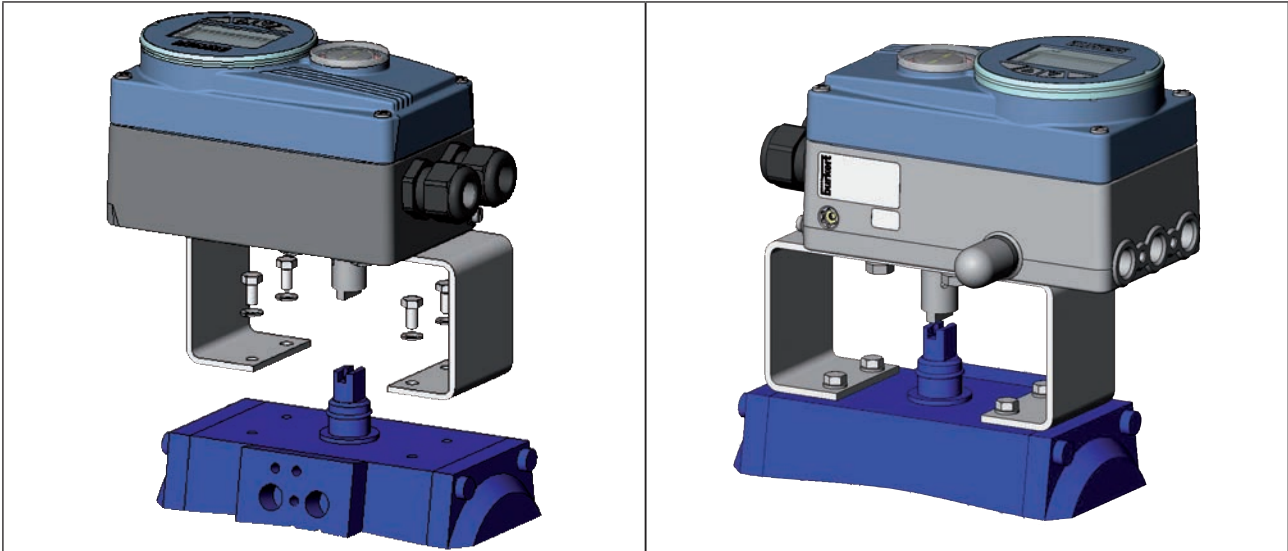


Figure 17: Swivel actuator attachment



If the X.TUNE ERROR 5 message is indicated after the X.TUNE function starts, the shaft of Type 8792/8793 is not correctly aligned with the shaft of the actuator (see “Error message for P.Q.’LIN; process controller Type 8793” on page 177).

- Check alignment (as described previously in this chapter).
- Then repeat the X.TUNE function.

## 11.4 Remote operation with external position sensor

In the case of this variant, the positioner has no position sensor in the form of a rotary position sensor, but an external position sensor.

Depending on the variant of Type 8792/8793, there are the following connection variants:

Device type	Interface	Position sensor	Setting in the menu (ADD.FUNCTION)
Type 8792 Remote	digital (serial)	Remote sensor Type 8798	–
Type 8793 Remote	digital (serial)	Remote sensor Type 8798	POS.SENSOR → DIGITAL For menu description see chapter “16.1.21 POS.SENSOR”
	analog (4...20 mA) *	any high-resolution position sensor	POS.SENSOR → ANALOG For menu description see chapter “16.1.21 POS.SENSOR”

Table 12: Connection variants of external position sensor



\* If the external position sensor is connected to the process controller Type 8793 via the analog interface, it can be operated only as a positioner (position controller).

### 11.4.1 Mounting accessories

There are two options of attaching the Type 8792/8793 in remote operation (see “Figure 18”).

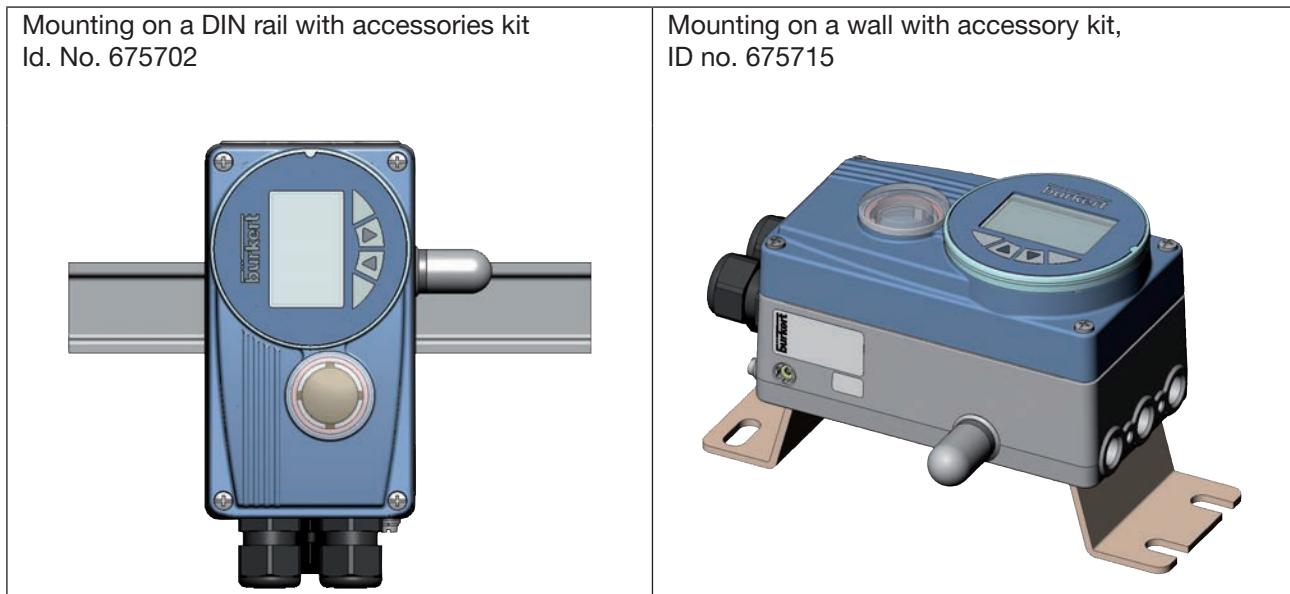


Figure 18: Attachment types in remote operation

### 11.4.2 Connection and start-up of the remote sensor Type 8798



#### WARNING

Risk of injury due to improper start-up.

- ▶ Start-up may be carried out by authorized technicians only and with the appropriate tools.

Risk of injury due to unintentional switching on of the plant and uncontrolled start-up.

- ▶ Secure the device against accidental activation.
- ▶ Following assembly, ensure a controlled restart.

→ Connect the 3 or 4 wires of the sensor cable to the designated screw-type terminals of Type 8792/8793.  
**Connection of screw-type terminals:** See chapter “[12.2.2.4. Terminal assignment for external position sensor \(for remote variant only\)](#)” on page 50

**Connection of M8 circular plug** (only for Ethernet (Ethernet/IP, PROFINET I/O, Modbus TCP) and bÜS):  
See chapter “[19.5 X4 - M8 socket, 4-pole, optional - Remote sensor \(for remote variant only\)](#)” on page 165

- Mount remote sensor on the actuator.  
The proper procedure is described in the summary instructions of remote sensor Type 8798.
- Connect compressed air to the positioner.

- Connect positioner pneumatically to the actuator.
- Switch on the operating voltage of Type 8792/8793:
- Run the *X.TUNE* function.

### 11.4.3 Connection and start-up of an external 4...20 mA position sensor (only for Type 8793 remote variant)



Process controller Type 8793 can only be used as a positioner (position controller) when an external position sensor 4...20 mA is connected as the process actual value input is used as the input for the external position sensor.

It is generally possible to connect any position sensor having an output 4...20 mA that has an appropriate resolution of the position signal.

Good control characteristics are achieved when the resolution of the position sensor allows at least 1,000 measurement steps along the path to be detected.

Example: Position sensor with measurement range 150 mm;  
thereof measurement range used (= stroke) 100 mm

Required minimum sensor resolution:

$$\frac{100 \text{ mm}}{1000 \text{ steps}} = 0.1 \text{ mm}$$



#### WARNING

**Risk of injury due to improper start-up.**

- ▶ Start-up may be carried out by authorized technicians only and with the appropriate tools.

**Risk of injury due to unintentional switching on of the plant and uncontrolled start-up.**

- ▶ Secure the device against accidental activation.
- ▶ Following assembly, ensure a controlled restart.

- Connect the external position sensor 4...20 mA with terminals 1 - 4 of the process controller Type 8793 remote variant. (See chapter [“12.2.3.1. Terminal assignments of the process actual value input”](#))
- Internal supply of the external position sensor by Type 8793:
  - connection according to input type “4...20 mA - internally supplied”

Separate supply of the external position sensor:

- connection according to input type “4...20 mA - externally supplied”.

- Attach external position sensor on the actuator.  
The proper procedure is described in the instructions of the external position sensor.
- Connect the compressed air to Type 8793.
- Connect Type 8793 pneumatically to the actuator.
- Switch on operating voltage of Type 8793.



- To achieve the best-possible control accuracy, set the external position sensor such that the past to be detected corresponds to the signal range 4...20 mA (only if the external position sensor includes this function).
- In the *ADD.FUNCTION* menu activate the *POS.SENSOR* function. Then select *POS.SENSOR* in the main menu and set *ANALOG* (see chapter [“16.1.21 POS.SENSOR”](#) on page 118).
- Run the *X.TUNE* function.

## 11.5 Pneumatic connection

### 11.5.1 Safety instructions



#### DANGER

Risk of injury from high pressure in the system.

- ▶ Before loosening lines and valves, turn off the pressure and vent the lines.



#### WARNING

Risk of injury from improper installation.

- ▶ Installation may be carried out by authorized technicians only and with the appropriate tools.

Risk of injury due to unintentional switching on of the plant and uncontrolled start-up.

- ▶ Secure the device against accidental activation.
- ▶ Following installation, ensure a controlled restart.

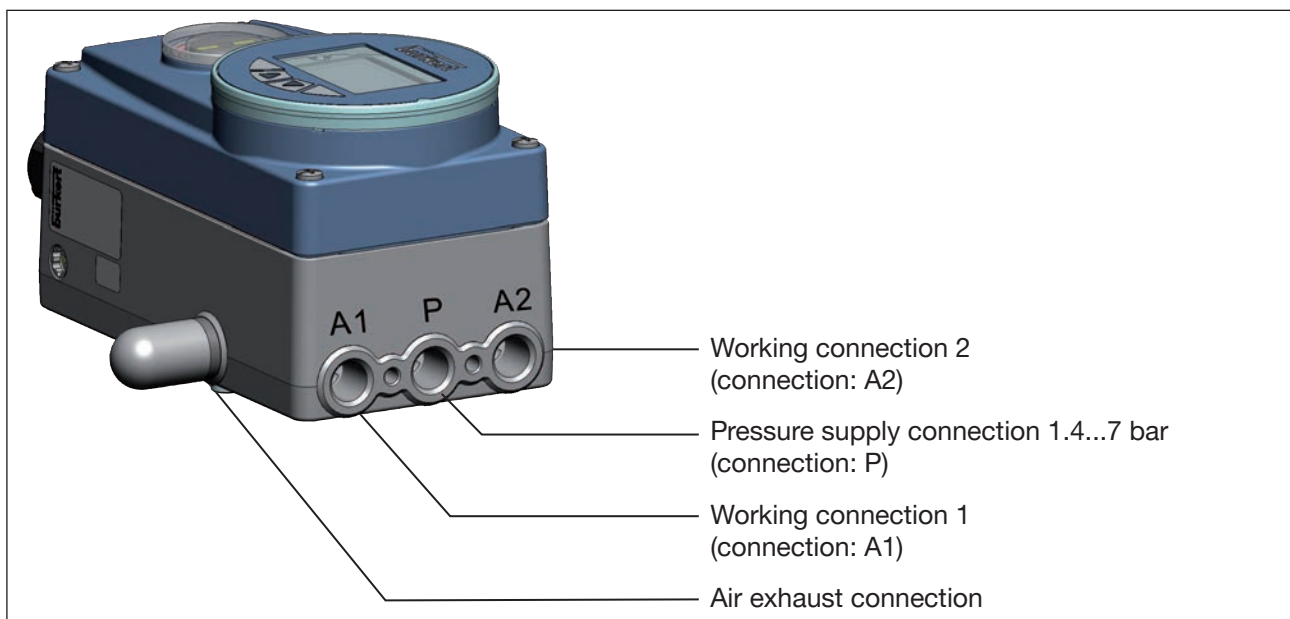


Figure 19: Fluid installation / Location of the connections

**Procedure:**

→ Apply supply pressure (1.4...7 bar) to the pressure supply connection P.

**For single-acting actuators (control function A and B):**

→ Connect one working connection (A1 or A2, depending on required safety end position) to the chamber of the single-acting actuator.

See chapter "[10.9. Safety end positions after failure of the electrical or pneumatic auxiliary power](#)".

→ Seal a working connection which is not required with a plug.

**For double-acting actuators (control function I):**

→ Connect working connections A1 and A2 to the respective chambers of the double-acting actuator.

See chapter "[10.9. Safety end positions after failure of the electrical or pneumatic auxiliary power](#)".

**Important information for perfect control behavior.**

In order to ensure that the control behavior is not negatively affected in the upper stroke range on account of too little pressure difference

- keep the applied supply pressure always 0.5...1 bar above the pressure which is the minimum required to move the pneumatic actuator to its end position.

If fluctuations are greater, the controller parameters measured with the *X.TUNE* function are not optimal.

- During operation keep the fluctuations of the supply pressure as low as possible (max.  $\pm 10\%$ ).

## 12 ELECTRICAL INSTALLATION

There are 2 connection variants for Type 8792, 8793:

- Multipole with circular plug-in connector
- Cable gland with connection terminals

### Signal values

Operating voltage:	24 V DC
Set-point value (process/position controller):	0...20 mA; 4...20 mA 0...5 V; 0...10 V
Actual value (only process controller):	4...20 mA; frequency; Pt 100

### 12.1 Electrical installation with circular plug-in connector (multipole version)



#### DANGER

Risk of injury from electric shock.

- ▶ Before reaching into the device or the equipment, switch off the power supply and secure to prevent reactivation.
- ▶ Observe applicable accident prevention and safety regulations for electrical equipment.



#### WARNING

Risk of injury from improper installation.

- ▶ Installation may be carried out by authorized technicians only and with the appropriate tools.

Risk of injury due to unintentional switching on of the plant and uncontrolled start-up.

- ▶ Secure the device against accidental activation.
- ▶ Following installation, ensure a controlled restart.



#### Use of the set-point value input 4 - 20 mA

If several devices of Type 8792/8793 are connected in series and the power supply to a device in this series connection fails, the input of the failed device becomes highly resistive. As a result, the 4 - 20 mA standard signal fails. In this case please contact Bürkert Service directly.

With Ethernet (Ethernet IP, Profinet I/O, Modbus TCP) or bÜS)

Please find the designations of the circular plug-in connectors, sockets and contacts in the respective chapters.

### 12.1.1 Type 8792 - designation of the circular plug-in connectors

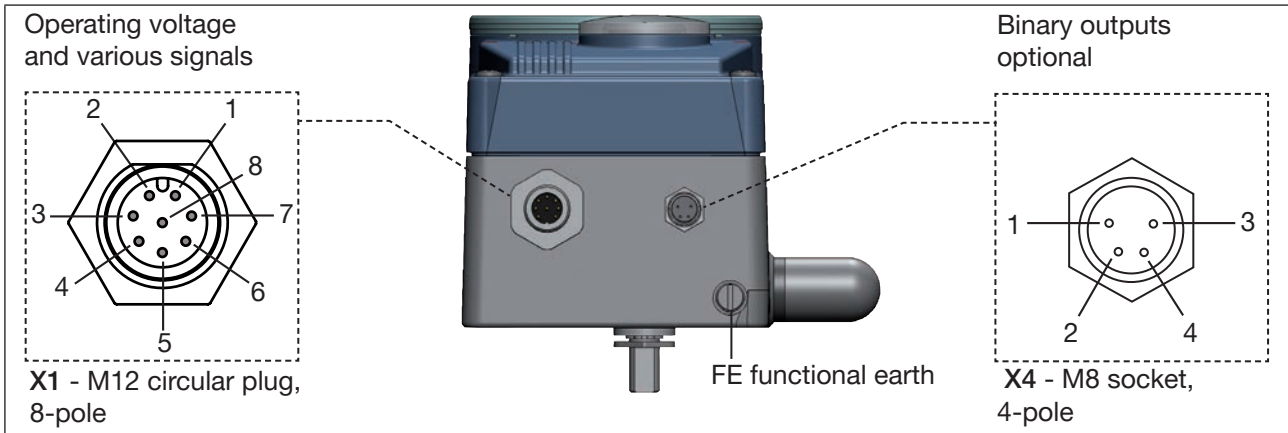


Figure 20: Type 8792; designation of the circular plug-in connectors and contacts

### 12.1.2 Connection of positioner Type 8792

→ Connect pins according to the variant (options) of the positioner.

### 12.1.3 X1 - M12 circular plug, 8-pole

Pin	Wire color*	Assignment	On the device side	External circuit / signal level
<b>Input signals from the control center (e.g. PLC)</b>				
1	white	Set-point value + (0 / 4...20 mA or 0...5 / 10 V)	1 ○ — + (0/4...20 mA or 0...5 / 10 V) fully galvanically isolated	
2	brown	Set-point value	2 ○ — GND set-point value	
5	gray	Binary input	5 ○ — +	0...5 V (log. 0) 10...30 V (log. 1)
6	pink	Binary input GND	6 ○ — GND (identical to GND operating voltage)	
<b>Output signals to the control center (e.g. PLC) - (assigned for the analog output option only)</b>				
8	red	Analog feedback +	8 ○ — + (0/4...20 mA or 0...5 / 10 V) fully galvanically isolated	
7	blue	Analog feedback GND	7 ○ — GND analog feedback	
<b>Operating voltage</b>				
3	green	GND	3 ○ —	24 V DC ± 10% max. residual ripple 10%
4	yellow	+ 24 V	4 ○ —	
* The indicated wire colors refer to the connection cable, ID no. 919061, available as an accessory.				

### 12.1.3.1. X4 - M8 socket, 4-pole (for the binary output option only) output signals to the control center (e.g. PLC)

Pin	Assignment	On the device side	External circuit / signal level
1	Binary output 1	1	0...24 V
2	Binary output 2	2	0...24 V
3	Binary output GND	3	GND (identical to GND operating voltage)

Table 14: Pin assignment; X4 - M8 socket, 4-pole - output signals to the control center

When the operating voltage is applied, the positioner is operating.

→ Now make the required basic settings and actuate the automatic adjustment of the positioner. The procedure is described in chapter “14 Start-up” on page 64.

### 12.1.4 Type 8793 - designation of the circular plug-in connectors and contacts

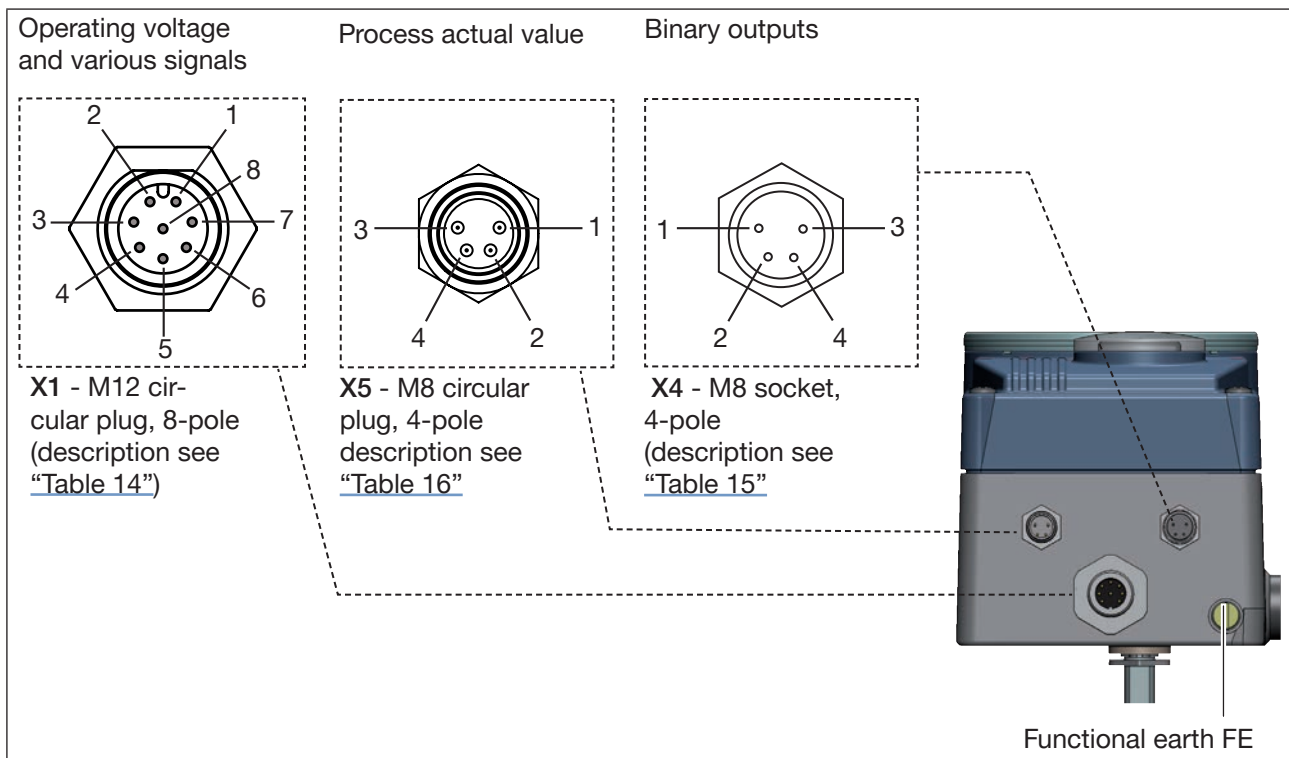


Figure 21: Type 8793; designation of the circular plug-in connectors and contacts

MAN 1000341264 EN Version: C Status: RL (released | freigegeben) printed: 09.12.2019

Location of the switch:

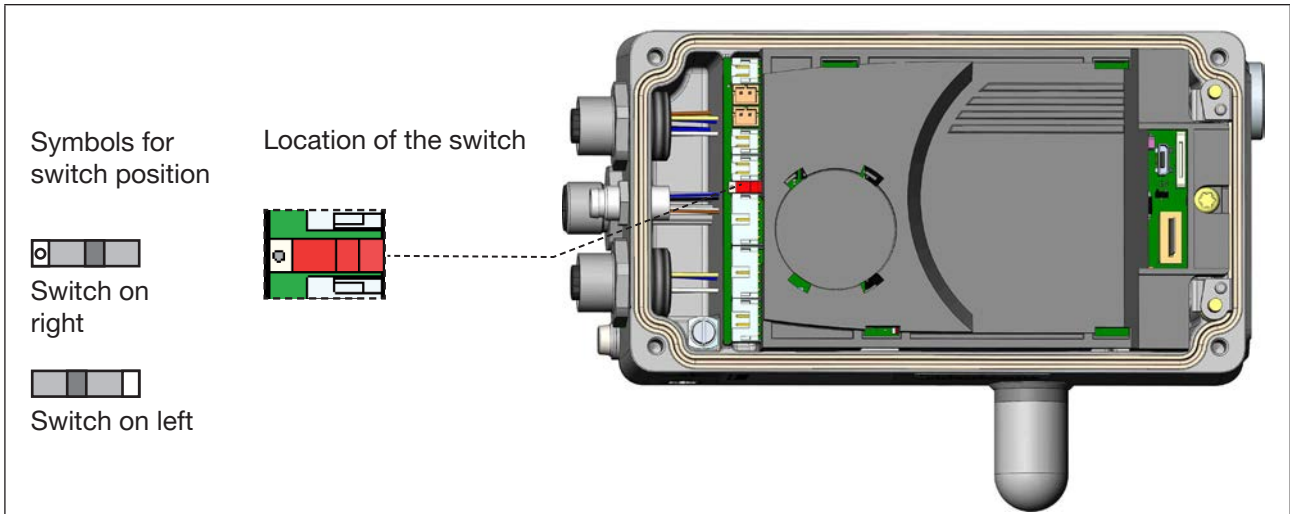

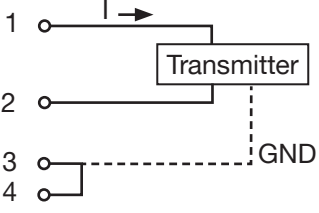

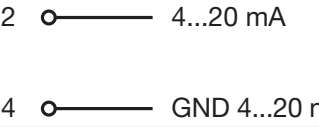

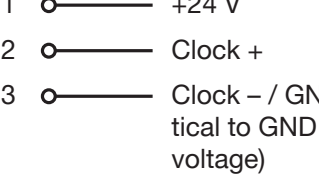


Figure 22: Location of the switch; symbols for switch position

### 12.1.5 Connection of the process controller Type 8793

→ First connect the process controller as described in chapter “12.1.2” to “12.1.4”.

### 12.1.6 X5 - M8 circular plug, 4-pole, input signals process actual value (for Type 8793 only)

Input type*	Pin	Assignment	Switch ***	On the device side	External circuit
4...20 mA - internally supplied	1	+24 V transmitter power supply	 Switch on left		
	2	Output from transmitter			
	3	GND (identical to GND operating voltage)			
	4	Bridge after GND (GND from 3-conductor transmitter)			
4...20 mA - externally supplied	1	Not assigned	 Switch on right		
	2	Process actual +			
	3	Not assigned			
	4	Process actual -			
Frequency - internally supplied	1	+24 V sensor power supply	 Switch on left		
	2	Clock input +			
	3	Clock input - (GND)			
	4	Not assigned			

Input type*	Pin	Assignment	Switch ***	On the device side	External circuit
Frequency - externally supplied	1	Not assigned			
	2	Clock input +	Switch on right	2	Clock +
	3	Clock input -		3	Clock -
	4	Not assigned		2	
Pt 100 (see information below)	1	Not assigned			
	2	Process actual 1 (power supply)	Switch on right	3	
	3	Process actual 3 (GND)		4	
	4	Process actual 2 (compensation)			

\* Can be adjusted via software (see chapter "15.2.1 PV-INPUT – Specifying signal type for the process actual value" on page 70).

\*\* The indicated wire colors refer to the connection cable, ID no. 92903474, available as an accessory.

\*\*\* Position of the switch, see "Figure 20: Type 8792; designation of the circular plug-in connectors and contacts"

Table 15: X5 - M8 circular plug, 4-pole, input signals process actual value (for Type 8793 only)

**!** For reasons of wire compensation connect the Pt 100 sensor via 3 wires. Always bridge Terminal 3 and Terminal 4 on the sensor.

When the operating voltage is applied, the process controller is operating.

→ Now make the required basic settings and actuate the automatic adjustment of the process controller. The procedure is described in chapter "14 Start-up" on page 64.

### 12.1.7 Slide switch position

Supplied	Assignment	Slide switch position
Internally supplied	GND operating voltage	Slide switch on left
Externally supplied	GND is galvanically isolated from the operating voltage.	Slide switch on right

Table 16: Slide switch position

**!** The description EtherNet/IP, PROFINET and Modbus TCP can be found in chapter "19". The description büS option can be found in chapter "20".

MAN 1000341264 EN Version: C Status: RL (released | freigegeben) printed: 09.12.2019

## 12.2 Electrical installation with cable gland

### **!** DANGER

Risk of injury from electric shock.

- ▶ Before reaching into the device or the equipment, switch off the power supply and secure to prevent reactivation.
- ▶ Observe applicable accident prevention and safety regulations for electrical equipment.

### **!** WARNING

Risk of injury from improper installation.

- ▶ Installation may be carried out by authorized technicians only and with the appropriate tools.

Risk of injury due to unintentional switching on of the plant and uncontrolled start-up.

- ▶ Secure the device against accidental activation.
- ▶ Following installation, ensure a controlled restart.

### **!** Use of the set-point value input 4 - 20 mA

If several devices of Type 8792/8793 are connected in series and the power supply to a device in this series connection fails, the input of the failed device becomes highly resistive. As a result, the 4 - 20 mA standard signal fails. In this case please contact Bürkert Service directly.

### 12.2.1 Terminal board Type 8792/8793 with screw-type terminals

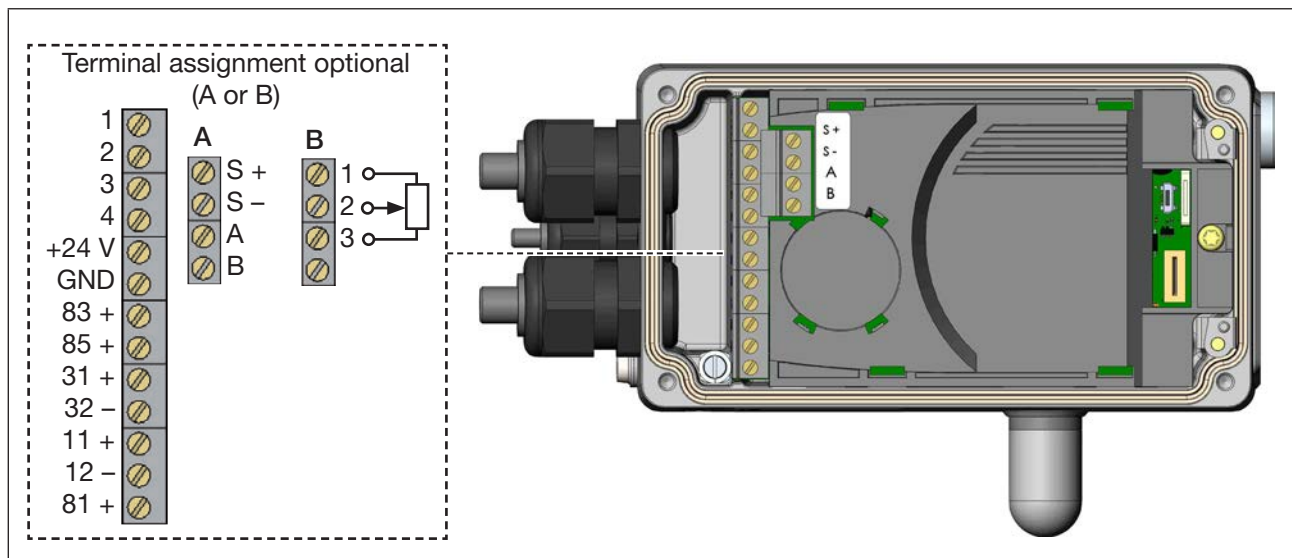


Figure 23: Designation of the screw-type terminals

Procedure:

→ Unscrew the 4 screws of the housing cover and remove the cover.

The screw-type terminals are now accessible.

→ Connect Type 8792/8793.

The procedure is described in the following chapters

for Type 8792: Chapter "12.2.2 Terminal assignment for cable gland - Type 8792"

for Type 8793: Chapter "12.2.3 Terminal assignment for cable gland - Type 8793".



## 12.2.2 Terminal assignment for cable gland - Type 8792

### 12.2.2.1. Input signals from the control center (e.g. PLC)





Terminal	Assignment	On the device side	External circuit / signal level
11 +	Set-point value +	11 + 	(0/4...20 mA or 0...5 / 10 V) fully galvanically isolated
12 -	Set-point value GND	12 - 	GND set-point value
81 +	Binary input +	81 + 	+  0...5 V (log. 0) 10...30 V (log. 1) specific to operating voltage GND (terminal GND)

Table 17: Terminal assignment; input signals of the control center

### 12.2.2.2. Terminal assignment: Output signals to the control center (e.g. PLC) - (required for analog output and/or digital output option only)

→ Connect terminals according to the variant (options) of the positioner.





Terminal	Assignment	On the device side	External circuit / signal level
83 +	Binary output 1	83 + 	24 V / 0 V, NC / NO specific to operating voltage GND (terminal GND)
85 +	Binary output 2	85 + 	24 V / 0 V, NC / NO specific to operating voltage GND (terminal GND)
31 +	Analog feedback +	31 + 	+ (0/4...20 mA or 0...5 / 10 V) fully galvanically isolated
32 -	Analog feedback GND	32 - 	GND analog feedback

Table 18: Terminal assignment; output signals to the control center

### 12.2.2.3. Operating voltage



Terminal	Assignment	On the device side	External circuit / signal level
+ 24 V	Operating voltage +	+ 24 V DC 	24 V DC ± 10% max. residual ripple 10%
GND	Operating voltage GND	GND 	

Table 19: Terminal assignment; operating voltage

### 12.2.2.4. Terminal assignment for external position sensor (for remote variant only)

Connection of the digital, non-contacting position sensor Type 8798:

Terminal	Wire color		Assignment	On the device side	External circuit / signal level
	Cable type 1	Cable type 2			
S +	brown	brown	Supply sensor +	S + ○ ——— +	
S -	white	black	Supply sensor -	S - ○ ——— -	
A	green	red	Serial interface, A cable	A ○ ——— A cable	
B	yellow	orange	Serial interface, B cable	B ○ ——— B cable	

Table 20: Terminal assignment; digital, non-contacting position sensor Type 8798

Connection of a potentiometric position sensor:

Terminal	Assignment	On the device side	External circuit
	Potentiometer 1	1 ○ ———	
	Sliding contact 2	2 ○ ———	
	Potentiometer 3	3 ○ ———	

Table 21: Terminal assignment; potentiometric position sensor

### 12.2.3 Terminal assignment for cable gland - Type 8793

→ First connect the process controller as described in chapter [“12.2.2 Terminal assignment for cable gland - Type 8792”](#).

### 12.2.3.1. Terminal assignments of the process actual value input

Input type*	Terminal	Assignment	On the device side	External circuit	
4...20 mA - internally supplied	actual value	1			
		2			Output from transmitter
		3			Bridge after GND (GND terminal from operating voltage)
		4			Not assigned
	GND	GND from operating voltage			
4...20 mA - externally supplied	actual value	1			
		2	Process actual +	2 ○ — + (4...20 mA)	
		3	Process actual -	3 ○ — GND 4...20 mA	
		4	Not assigned		
Frequency -internally supplied	actual value	1			
		2			Clock input +
		3			Not assigned
		4			Clock input -
	GND	GND from operating voltage	GND ○ — Clock - (GND)		
Frequency - externally supplied	actual value	1			
		2	Clock input +	2 ○ — Clock +	
		3	Not assigned		
		4	Clock input -	4 ○ — Clock -	
Pt 100 (see information below)	actual value	1			
		2			Process actual 1 (power supply)
		3			Process actual 3 (GND)
		4			Process actual 2 (compensation)

\*Can be adjusted via software (see chapter "21. Start-up sequence").

Table 22: Terminal assignments of the process actual value input

**!** For reasons of wire compensation connect the Pt 100 sensor via 3 wires.  
Always bridge Terminal 3 and Terminal 4 on the sensor.

When the operating voltage is applied, the process controller is operating.

→ Now make the required basic settings and actuate the automatic adjustment of the process controller.  
The procedure is described in chapter "14 Start-up" on page 64.

## 13 OPERATION

### WARNING

**Danger due to improper operation.**

Improper operation may result in injuries as well as damage to the device and its environment.

- ▶ The operating personnel must know and have understood the contents of the operating instructions.
- ▶ Observe the safety instructions and intended use.
- ▶ Only adequately trained personnel may operate the equipment/the device.

There is the process level and the setting level for the operation and setting of Type 8792/8793.

#### Process level:

The running process is displayed and operated on the process level.

Operating state:   AUTOMATIC – Displaying the process data  
                           MANU         – Manual opening and closing of the valve

#### Setting level:

The basic settings for the process are made on the setting level.

- Inputting the operating parameters
- Activating auxiliary functions



If the device is in the AUTOMATIC operating state when changing to the setting level, the process continues running during the setting.

### 13.1 Description of the operating and display elements

The device features 4 keys for operation and a 128x64 dot matrix graphics display as the display element.

The display is adjusted to the set functions and operating levels.

In principle, a distinction can be made between the display view for the process level and the setting level. When the operating voltage has been applied, the process level is displayed.

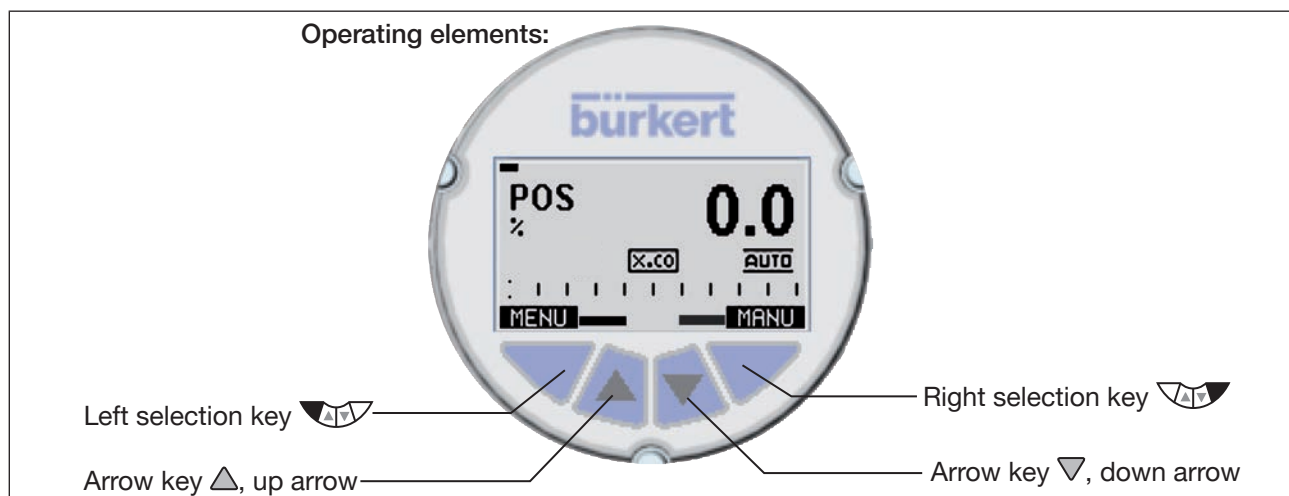


Figure 24: Operating elements

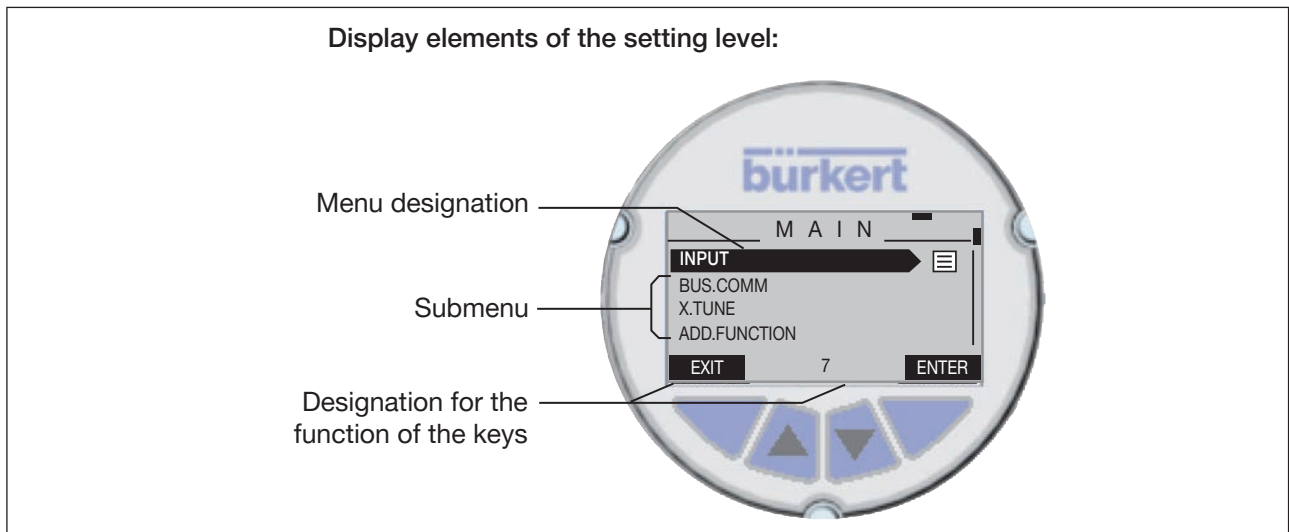


Figure 25: Display elements of the setting level

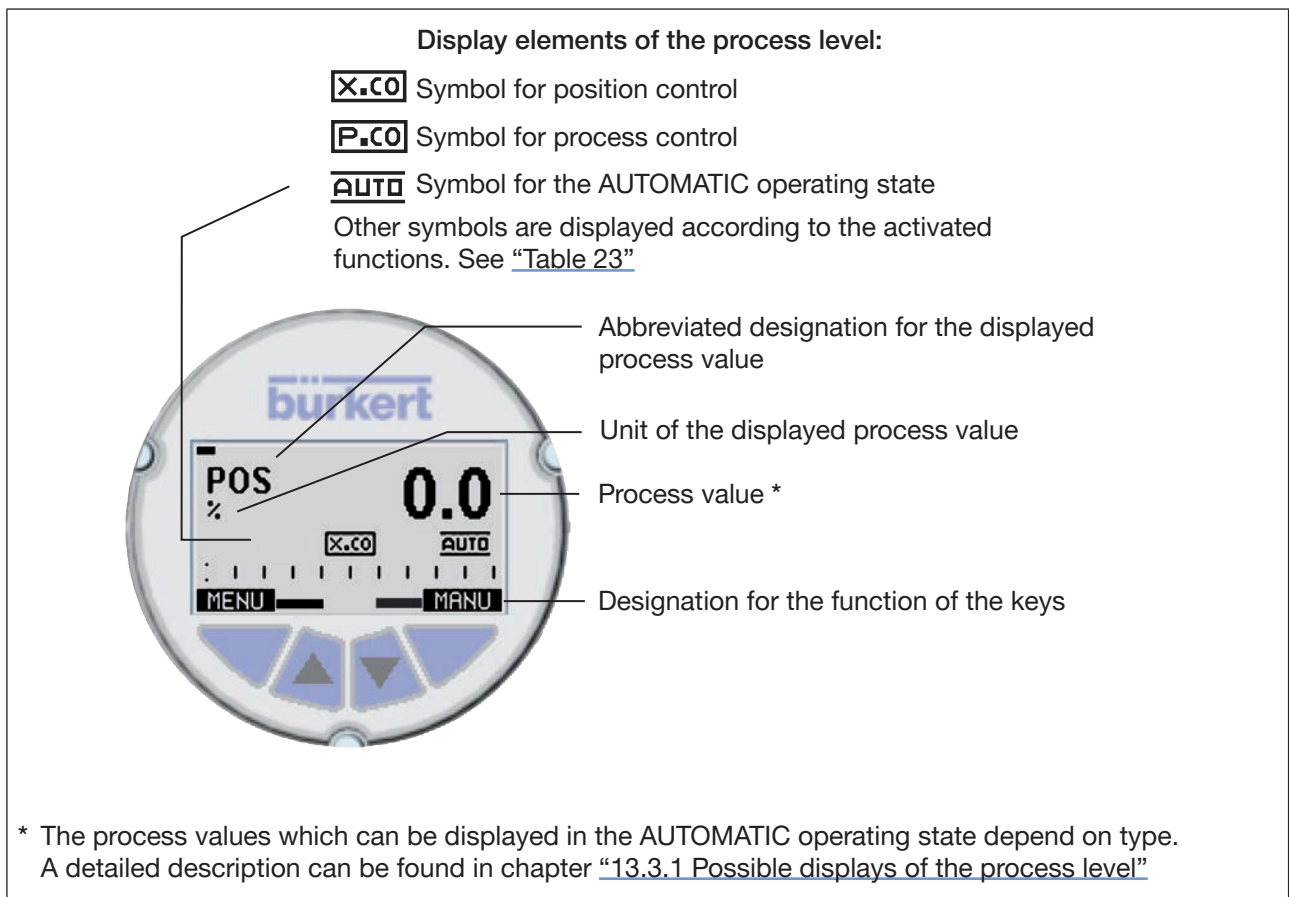


Figure 26: Display elements of the process level

MAN 1000341264 EN Version: C Status: RL (released | freigegeben) printed: 09.12.2019

### 13.1.1 Description of the symbols which are displayed on the process level

The symbols which are displayed depend on

- type,
- operation as position or process controller,
- AUTOMATIC or MANU operating state and
- the activated functions.

Operation	Icon	Description
Types 8792/8793		AUTOMATIC operating state
Operation as position controller	<input checked="" type="checkbox"/>	Diagnostics active (optional; only available if the device has the additional software for the diagnostics)
		X.CONTROL / Position controller active (symbol is indicated for Type 8793 only)
		CUTOFF active
		SAFEPOS active
		Interface I/O Burst
		Interface I/O RS232 HART
		SECURITY active
Other symbols for Type 8793		P.CONTROL / process controller active
		Bus active
		SIMULATION active

Table 23: Symbols of the process level.

### 13.1.2 Flashing of the display background lighting

Flashing is used to localize the device in a network. It is activated when selecting the device in the Bürkert-Communicator or when requested via a fieldbus.

## 13.2 Function of the keys

The function of the 4 keys for operation differs depending on the operating state (AUTOMATIC or MANU) and operating level (process level or setting level).

The key function which is active is displayed in the gray text field which is above the key.



The description of the operating levels and operating states can be found in chapter [“13 Operation”](#) and [“13.5 Operating states”](#).

Key function on the process level:			
Key	Key function	Description of the function	Operating state
Arrow key ▲	<b>OPN</b>	Manual opening of the actuator.	MANUAL
		Change the displayed value (e.g. <i>POS-CMD-TEMP-...</i> ).	AUTOMATIC
Arrow key ▼	<b>CLS</b>	Manual closing of the actuator.	MANUAL
		Change the displayed value (e.g. <i>POS-CMD-TEMP-...</i> ).	AUTOMATIC
left selection key 	<b>MENU</b>	Change to the setting level. Note: Press key for approx. 3 s.	AUTOMATIC or MANUAL
right selection key 	<b>AUTO</b>	Return to AUTOMATIC operating state.	MANUAL
	<b>MANU</b>	Change to MANUAL operating state.	AUTOMATIC

Key function on the setting level:		
Key	Key function	Description of the function
Arrow key ▲		Scroll up in the menus.
	<b>+</b>	Maximizing numerical values.
Arrow key ▼		Scroll down in the menus.
	<b>-</b>	Minimizing numerical values.
	<b>&lt;-</b>	Change by one digit to the left; when entering numerical values.
left selection key 	<b>EXIT</b>	Return to the process level.
		Gradually return from a submenu option.
	<b>ESC</b>	Leave a menu.
	<b>STOP</b>	Stop a sequence.
right selection key 	<b>ENTER</b>	Select, activate or deactivate a menu option.
	<b>SELEC</b>	
	<b>OK</b>	
	<b>INPUT</b>	
	<b>EXIT</b>	Gradually return from a submenu option.
	<b>RUN</b>	Start a sequence.
	<b>STOP</b>	Stop a sequence.

Table 24: Function of the keys

MAN 1000341264 EN Version: C Status: RL (released | freigegeben) printed: 09.12.2019

### 13.2.1 Entering and changing numerical values

Changing numerical values with fixed decimal places:









Key	Key function	Description of the function	Example
Arrow key ▾		Change to the next decimal place (from right to left). After reaching the last decimal place, the display switches back to the first decimal place.	Enter date and time.  
Arrow key ▲		Increase value. When the largest possible value has been reached, 0 is displayed again.	
left selection key 	 or 	Return without change.	
right selection key 		Accept the set value.	

Table 25: Change numerical values with fixed decimal places.

Enter numerical values with variable decimal places:









Key	Key function	Description of the function	Example
Arrow key ▲		Increase value.	Enter PWM signal  
Arrow key ▾		Reduce value.	
left selection key 	 or 	Return without change.	
right selection key 		Accept the set value.	

Table 26: Enter numerical values with variable decimal places.



### 13.3 Adjusting the display

The display can be individually adjusted for the operation and monitoring of the process.

- To do this, menu options can be activated for displaying the process level. *POS* and *CMD* are activated in the as-delivered state.
- The menu options which can be displayed depend on the type.



How you can adjust the display for Type 8792 individually to the process to be controlled is described in chapter “16.1.20 EXTRAS – Setting the display” on page 115.

#### 13.3.1 Possible displays of the process level

→ ▲ / ▼ select possible displays in AUTOMATIC operating state.

	<p>Actual position of the valve actuator (0 ....100%)</p>
	<ul style="list-style-type: none"> <li>• Set-point position of the valve actuator or</li> <li>• Set-point position of the valve actuator after rescaling by possibly activated split range function or correction characteristic (0 ....100%)</li> </ul>
	<p>Internal temperature in the housing of the device (°C)</p>
	<p>Process actual value  Only for Type 8793</p>
	<p>Process set-point value <i>Right selection key</i>  : <i>The key function depends on the set-point value default</i> <i>(menu: P.CONTROL → P.SETUP → SP-INPUT → internal/external).</i></p> <p><b>INPUT</b> Set-point value default = internal <b>MANU</b> Set-point value default = external</p> <p>Only for Type 8793</p>
	<p>Graphical display of <i>SP</i> and <i>PV</i> with time axis  Only for Type 8793</p>


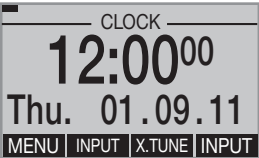
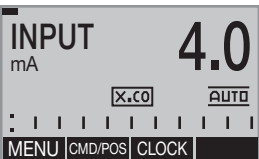
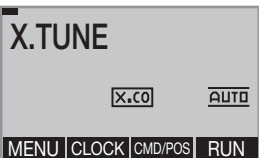
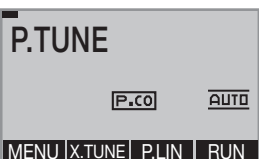

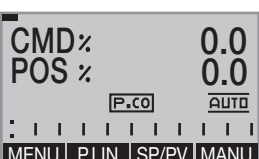
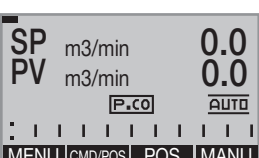
	<p>Graphical display of <i>POS</i> and <i>CMD</i> with time axis</p>
	<p>Time, weekday and date</p>
	<p>Input signal for set-point position (0...5/10 V or 0/4...20 mA)</p> <p>Only for operation as position controller <b>X.CO</b></p>
	<p>Automatic adjustment of the position controller</p>
	<p>Automatic optimization of the process controller parameters</p> <p>Only for Type 8793</p>
	<p>Automatic linearization of the process characteristics</p> <p>Only for Type 8793</p>
	<p>Simultaneous display of the set-point position and the actual position of the valve actuator (0...100%)</p>
	<p>Simultaneous display of the set-point position and the actual position of the valve actuator (0...100%)</p> <p>Only for Type 8793</p>

Table 27: Displays of the process level











## 13.4 Date and time

Date and time are set on the process level in the *CLOCK* menu.

To ensure that the menu for *CLOCK* can be selected on the process level, the following functions must be activated in 2 stages:

1. The *EXTRAS* auxiliary function in the *ADD.FUNCTION* menu
2. The *CLOCK* function in the *EXTRAS* auxiliary function, *DISP.ITEMS* submenu.

Activate *EXTRAS* and *CLOCK* as follows:

-  Press **MENU** for 3 s. Switching from process level ⇒ setting level.
- ▲ / ▼ Select *ADD.FUNCTION*.
-  Select **ENTER**. The possible auxiliary functions are displayed.
- ▲ / ▼ Select *EXTRAS*.
-  Select **ENTER**.  
Activate the *EXTRAS* auxiliary function by marking with a cross ☒ and transfer into the main menu (MAIN).
-  Select **EXIT**. Return to the main menu (MAIN).
- ▲ / ▼ Select *EXTRAS*.
-  Select **ENTER**. The submenus of *EXTRAS* are displayed.
- ▲ / ▼ Select *DISP.ITEMS*.
-  Select **ENTER**. The possible menu options are displayed.
- ▲ / ▼ Select *CLOCK*.
-  Select **SELECT**. The activated *CLOCK* function is now marked by a cross ☒.
-  Select **EXIT**. Return to the *EXTRAS* menu.
-  Select **EXIT**. Return to the main menu (MAIN).
-  Select **EXIT**. Switching from setting level ⇒ process level.
- ✔ You have activated *EXTRAS* and *CLOCK*.



Date and time must be reset whenever the device is restarted.




After a restart the device therefore switches immediately and automatically to the corresponding menu.

### 13.4.1 Setting date and time:

Activate the input screen as follows:

- On the process level select the display for *CLOCK* using the arrow keys ▲ ▼.
- Press **INPUT** to open the input screen for the setting.
- Set date and time as described in the following table.
- ✔ You have activated the input screen.

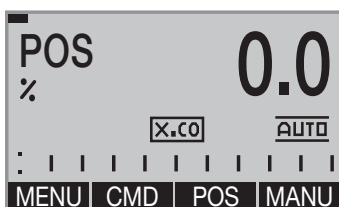
Set the date and time as follows:

- Select ▼ **<-** .  
Switch to the next time unit (from right to left).  
When the last time unit for the date has been reached, the display switches to the time units for the time.  
If the last unit is at top left (hours), the display switches back to the first unit at bottom right (year).
- Select ▲ **+** .  
Increase value.  
When the largest possible value has been reached, 0 is displayed again.
-  Select **ESC** . Return without change.
-  Select **OK** . Accept the set value.
- ▲ / ▼ Select *EXTRAS*.
-  Select **ENTER**. The submenus of *EXTRAS* are displayed.
- ▲ / ▼ Switching the display.
- ✔ You have set date and time.

## 13.5 Operating states

Type 8792/8793 has 2 operating states: AUTOMATIC and MANUAL.

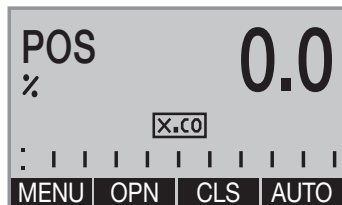
When the operating voltage is switched on, the device is in the AUTOMATIC operating state.



AUTOMATIC

In the AUTOMATIC operating state normal controlled operation is implemented.


(The symbol for AUTOMATIC AUTO is shown on the display. A bar runs along the upper edge of the display).



**MANUAL**

In the MANUAL operating state the valve can be manually opened or closed via the arrow keys  $\blacktriangle$   $\blacktriangledown$  (key function **OPN** and **CLS**).


(The symbol for AUTOMATIC **AUTO** is hidden. No bar running along the upper edge of the display).

 The MANUAL operating state (key function **MANU**) is for the following process value displays only:  
 POS, CMD, PV, CMD/POS, SP/PV.  
 For SP only for external process set-point value.

### 13.5.1 Changing the operating state

Switch to the MANUAL operating state as follows:

→  Select **MANU**.

-  You are in the MANUAL operating state.  
 Only available for process value display: POS, CMD, PV, SP


Switch to the AUTOMATIC operating state as follows:

→  Select **AUTO**.

-  You are in the AUTO operating state.

## 13.6 Activating and deactivating auxiliary functions

Auxiliary functions can be activated for demanding control tasks.

 The auxiliary function is activated via the *ADD.FUNCTION* basic function and transferred to the main menu (MAIN).  
 The auxiliary functions can then be selected and set in the extended main menu (MAIN).

### 13.6.1 Activating auxiliary functions

Activate the auxiliary functions as follows:

→  Press **MENU** for 3 s. Switching from process level  $\Leftrightarrow$  setting level.

→  $\blacktriangle$  /  $\blacktriangledown$  Select *ADD.FUNCTION*.

→  Select **ENTER**. The possible auxiliary functions are displayed.


→  $\blacktriangle$  /  $\blacktriangledown$  Select *auxiliary function*.

→  Select **ENTER**. The selected auxiliary function is now marked by a cross  $\boxtimes$ .



→  Select **EXIT**.  
 Acknowledgment and simultaneous return to the main menu (MAIN).

-  You have activated the marked function and included it in the main menu.

**Set the parameters as follows:**

- ▲ / ▼ Select *auxiliary function*. In the main menu (MAIN) select the auxiliary function.
-  Select **ENTER**. Opening the submenu to input the parameters.  
The setting of the submenu is described in the respective chapter of the auxiliary function.
- ✔ You have set the parameters.





**Return from the submenu and switch the process level as follows:**

-  Select **EXIT\*** or **ESC\***. Return to a higher level or to the main menu (MAIN).
-  Select **EXIT**. Switching from setting level ⇒ process level.
- ✔ You have changed the process level.

\* The designation of the key depends on the selected auxiliary function.

### 13.6.2 Deactivating auxiliary functions

**Deactivate the auxiliary functions as follows:**

-  Press **MENU** for 3 s. Switching from process level ⇒ setting level.
- ▲ / ▼ Select *ADD.FUNCTION*.
-  Select **ENTER**. The possible auxiliary functions are displayed.
- ▲ / ▼ Select *auxiliary function*.
-  Select **ENTER**. Remove function mark (no cross ).
-  Select **EXIT**.  
Acknowledgment and simultaneous return to the main menu (MAIN).
- ✔ You have deactivated the marked function and removed it from the main menu.



Deactivation removes the auxiliary function from the main menu (MAIN). This will cause the previous settings, created under this function, to be rendered invalid.

## 13.7 Manually opening and closing the valve

In the MANUAL operating state, the valve can be opened and closed manually using the arrow keys ▲ ▼.



The MANUAL operating state (key function **MANU**) is for the following process value displays:

- *POS*, actual position of the valve actuator.
- *CMD*, set-point position of the valve actuator.  
When switching to MANUAL operating state *POS* is displayed.
- *PV*, process actual value.
- *SP*, process set-point value.  
When switching to MANUAL operating state, *PV* is displayed. The switch is possible only for external set-point value default (menu: *P.CONTROL* → *P.SETUP* → *SP-INPUT* → *external*).
- *CMD/POS*, set-point position of the valve actuator.  
When switching to MANUAL operating state *POS* is displayed.
- *SP/PV*, process set-point value.  
When switching to MANUAL operating state, *PV* is displayed. The switch is possible only for external set-point value default (menu: *P.CONTROL* → *P.SETUP* → *SP-INPUT* → *external*).

### Manually open and close as follows:

→ ▲ / ▼ Select *POS*, *CMD*, *PV* or *SP*.

→  Select **MANU**. Change to MANUAL operating state.

→ Select ▲. Aerating the actuator

Control function A (SFA):	Valve opens
Control function B (SFB):	Valve closes
Control function I (SFI):	Connection 2.1 aerated

→ Select ▼. Deaerating the actuator

Control function A (SFA):	Valve closes
Control function B (SFB):	Valve opens
Control function I (SFI):	Connection 2.2 aerated

✓ You have manually opened and closed the valve.



- SFA:** Actuator spring force closing
- SFB:** Actuator spring force opening
- SFI:** Double-acting actuator

## 14 START-UP



Before start-up, carry out fluid and electrical installation of Type 8792/8793 and of the valve. For description see chapter “11” and “12”.

When the operating voltage is applied, Type 8792/8793 is operating and is in the AUTOMATIC operating state. The display shows the process level with the values for *POS* and *CMD*.

The following basic settings must be made for starting up the device:

Device type	Sequence	Type of basic setting	Setting via	Description in chapter	Requirement
8792 and 8793	1	Basic setting of the device: Set input signal (standard signal).	<i>INPUT</i>	“14.3”	essential
	2	Adjust device to the local conditions.	<i>X.TUNE</i>	“14.4”	
only 8793 (Process controller)	3	Activate process controller.	<i>ADD.FUNCTION</i>	“14.5”	essential
	4	Basic setting of the process controller: – Setting the hardware – Parameter setting of the software.	<i>P.CONTROL</i>	“15”	
	5		→ <i>SETUP</i>	“15.2”	
	6	Automatic linearization of the process characteristics.	<i>P.Q'LIN</i>	“15.4”	to be performed optionally
	7	Automatic parameter setting for the process controller.	<i>P.TUNE</i>	“15.5”	

Table 28: Start-up sequence

The basic settings are made on the setting level.

To switch from the process to the setting level, press the **MENU** key for approx. 3 seconds.

Then the main menu (MAIN) of the setting level is indicated on the display.

### 14.1 Safety instructions



#### WARNING

Risk of injury due to incorrect operation.

Improper operation may result in injuries as well as damage to the device and the area around it

- ▶ Before start-up, ensure that the operating personnel are familiar with and completely understand the contents of the operating instructions.
- ▶ Observe the safety instructions and intended use.
- ▶ Only adequately trained personnel may start up the equipment/the device.



## 14.2 Basic setting of the device








The following settings must be made for the basic setting of Type 8792/8793:

1.  Selection of the input signal (see chapter "14.3").
2.  Automatic self-parameterization of the position controller (see chapter "14.5")

## 14.3 INPUT - Setting the input signal

This setting is used to select the input signal for the set-point value.

Set the input signal as follows:

-  Press **MENU** for 3 s. Switching from process level ⇒ setting level.
-  Select **INPUT**.
-  Select **ENTER**. The possible input signals for **INPUT** are displayed.
-  Select input signal (4...20 mA, 0...20 mA, ...) Select.
-  Select **SELECT**. The selected input signal is now marked by a filled circle ●.
-  Select **EXIT**.  
Return to the main menu (MAIN).
-  Select **EXIT**. Switching from setting level ⇒ process level.
- ✔ You have set the input signal.

## 14.4 X.TUNE – Automatic adjustment of the position controller

### **WARNING**

Danger due to the valve position changing when the *X.TUNE* function is running!

When the *X.TUNE* function is run under operating pressure, there is an acute risk of injury.

- ▶ Never run *X.TUNE* while the process is running.
- ▶ Secure the device against accidental activation.

### **NOTE**

An incorrect supply pressure or incorrectly connected operating medium pressure may cause the controller to be wrongly adjusted.

- ▶ Run *X.TUNE* in each case at the supply pressure available in subsequent operation (= pneumatic auxiliary power).
- Run the *X.TUNE* function preferably **without** operating medium pressure to exclude interference due to flow forces.


The following functions are actuated automatically:

- Adjustment of the sensor signal to the (physical) stroke of the actuator used.
- Determination of parameters of the PWM signals to control the solenoid valves integrated in Type 8792, 8793.
- Adjustment of the controller parameters for the position controller. Optimization occurs according to the criteria of the shortest possible transient time without overshoots.

Automatically adjust the position controller as follows:

→  Press **MENU** for 3 s. Switching from process level ⇒ setting level.


→  Select *X.TUNE*.

→  Select **RUN**. Hold down as long as countdown (5 ...) is running.

During the automatic adjustment messages are displayed indicating the progress of the *X.TUNE* (e.g. “TUNE #1...”).

*When the automatic adjustment ends, the message “X.TUNE READY” is indicated.*

→ Select any key. Return to the main menu (MAIN).

→  Select **EXIT**. Switching from setting level ⇒ process level.

 You have automatically adjusted the position controller.



To stop *X.TUNE*, press the left or right selection key **STOP**.

**Automatically determining dead band DBND by running X.TUNE:**


When X.TUNE is running, the dead band can be automatically determined depending on the friction behavior of the actuating drive.

Before running X.TUNE, the X.CONTROL auxiliary function must be activated by incorporating it into the main menu (MAIN).

If X.CONTROL is not activated, a fixed dead band of 1% is used.



The changed data is saved in the memory (EEPROM) only when there is a switch to the process level, by leaving the main menu (MAIN) using the left selection key **EXIT**.

**Possible error messages when running X.TUNE:**

Display	Causes of error	Remedy
TUNE err/break	Manual termination of self-optimization by pressing the <b>EXIT</b> key.	
X.TUNE locked	The X.TUNE function is blocked.	Enter access code.
X.TUNE ERROR 1	No compressed air connected.	Connect compressed air.
X.TUNE ERROR 2	Compressed air failure while Autotune (X.TUNE) is running.	Check compressed air supply.
X.TUNE ERROR 3	Actuator or control system deaeration side leaking.	Not possible, device defective.
X.TUNE ERROR 4	Control system aeration side leaking.	Not possible, device defective.
X.TUNE ERROR 5	The rotation range of the position sensor has exceeded 180°.	Correct attachment of the position sensor shaft to the actuator (see <a href="#">chapter "12.2"</a> and <a href="#">"12.3"</a> ).
X.TUNE ERROR 6	The end positions for POS-MIN and POS-MAX are too close together.	Check compressed air supply.
X.TUNE ERROR 7	Incorrect assignment POS-MIN and POS-MAX.	To determine POS-MIN and POS-MAX, move the actuator in the direction indicated on the display.
X.TUNE WARNING 1*	Potentiometer is not coupled optimally to the actuator.  An optimum connection can provide a more accurate position measurement.	Set the center position as described in <a href="#">chapter "12.2.4. Aligning lever mechanism"</a> .

\* Warning information gives tips for optimized operation. The device is operational even if this warning information is not observed. Warning information is automatically hidden after several seconds.


Table 29: X.TUNE; possible error messages

After making the settings described in chapters ["23.1"](#) and ["23.2"](#), the positioner (position controller) is ready for use.

Activation and configuration of auxiliary functions is described in the following chapter ["26. Configuring the auxiliary functions"](#).

### 14.4.2.1. X.TUNE.CONFIG – Manual configuration of X.TUNE

This function is needed for special requirements only.

 For standard applications the X.TUNE function (automatic adjustment of the positioner), as described above, is run using the factory default settings.








The description of the X.TUNE.CONFIG function can be found in Chapter [“26.3. Manual configuration of X.TUNE”](#).


## 14.5 Activation of the process controller

The process controller is activated by selecting the P.CONTROL auxiliary function in the ADD.FUNCTION menu.

The activation transfers P.CONTROL into the main menu (MAIN) where it is available for further settings.

Activate the process controller as follows:

-  Press **MENU** for 3 s. Switching from process level ⇒ setting level.
  -  Select **ADD.FUNCTION**.
  -  Select **ENTER**. The possible auxiliary functions are displayed.
  -  Select **P.CONTROL**.
  -  Select **ENTER**. P.CONTROL is now marked by a cross ☒.
  -  Select **EXIT**. Acknowledgment and simultaneous return to the main menu (MAIN). P.CONTROL is now activated and incorporated into the main menu.
-  You have activated the process controller.

 Following activation of P.CONTROL, the P.Q'LIN and P.TUNE menus are also available in the main menu (MAIN). They offer support for the setting of the process control.

<b>P.Q'LIN</b>	Linearization of the process characteristic Description see chapter <a href="#">“25.4”</a>
<b>P.TUNE</b>	Self-optimization of the process controller (process tune) Description see chapter <a href="#">“25.5”</a>

### ADD.FUNCTION – Add auxiliary functions







Apart from activating the process controller, ADD.FUNCTION can be used to activate auxiliary functions and incorporate them into the main menu.

The description can be found in chapter [“26. Configuring the auxiliary functions”](#) on page 78.









## 15 BASIC SETTING OF THE PROCESS CONTROLLER

### 15.1 *P.CONTROL* – Setting up and parameterization of the process controller

Set up the process controller as follows:

-  Press **MENU** for 3 s. Switching from process level  $\Rightarrow$  setting level.
-  Select *P.CONTROL*. Selection in the main menu (MAIN).
-  Select **ENTER**. The submenu options for the basic setting are displayed.
-  Select *SETUP*.
-  Select **ENTER**. The menu for setting up the process controller is displayed.  
Setting up is described in chapter [“15.2 SETUP – Setting up the process controller”](#).
-  Select **EXIT**. Return to *P.CONTROL*.
- ✔ You have set up the process controller.

Parameterize the process controller as follows:

-  Press **MENU** for 3 s. Switching from process level  $\Rightarrow$  setting level.
-  Select *P.CONTROL*. Selection in the main menu (MAIN).
-  Select **ENTER**. The submenu options for the basic setting are displayed.
-  Select *PID.PARAMETER*.
-  Select **ENTER**. The menu for parameterizing the process controller is displayed.  
Parameterization is described in chapter [“15.3 PID.PARAMETER – Parameterizing the process controller”](#).
-  Select **EXIT**. Return to *P.CONTROL*.
-  Select **EXIT**. Return to the main menu (MAIN).
-  Select **EXIT**. Switching from setting level  $\Rightarrow$  process level.
- ✔ You have parameterized the process controller.

## 15.2 SETUP – Setting up the process controller

These functions specify the type of control.

The procedure is described in the following chapters “15.2.1” to “15.2.5”.




### 15.2.1 PV-INPUT – Specifying signal type for the process actual value

One of the following signal types can be selected for the process actual value:

- Standard signal                      4...20 mA                      flow rate, pressure, level
- Frequency signal                      0...1000 Hz                      flow rate
- Circuit with Pt 100                      -20...+220 °C                      temperature

Factory setting: 4...20 mA


Specify the signal type *PV-INPUT* in the *SETUP* menu:

- ▲ / ▼ Select *PV-INPUT*.
-  Select **ENTER**. The signal types are displayed.
- ▲ / ▼ Select signal type.
-  Select **SELECT**. The selected signal type is now marked by a filled circle ●.
-  Select **EXIT**. Return to *SETUP*.
- ✔ You have specified the signal type.

### 15.2.2 PV-SCALE– Scaling of the process actual value

The following settings are specified in the submenu of *PV-SCALE*:

- PVmin*
1. The physical unit of the process actual value.
  2. Position of the decimal point of the process actual value.
  3. Lower scaling value of the process actual value.

 In *PVmin* the unit of the process actual value and the position of the decimal point are specified for all scaling values (*SPmin*, *SPmax*, *PVmin*, *PVmax*).

- PVmax* Upper scaling value of the process actual value.

- K factor* K factor for the flow sensor  
The menu option is available only for the frequency signal type (*PV-INPUT* → *Frequency*).

### 15.2.2.1. Effects and dependencies of the settings of PV-INPUT on PV-SCALE

The settings in the PV-SCALE menu have different effects, depending on the signal type selected in PV-INPUT.

**!** Even the selection options for the units of the process actual value (in PVmin) depend on the signal type selected in PV-INPUT.

See following "Table 40"

Settings in the submenu of PV-SCALE	Description of the effect	Dependency on the signal type selected in PV-INPUT		
		4 - 20 mA	PT 100	Frequency
PVmin	Selectable unit of the process actual value for the physical variables.	Flow rate, temperature, pressure, length, volume. (as well as ratio as% and no unit)	Temperature	Flow rate
	Adjustment range:	0...9999 (temperature -200...800)	-200...800	0...9999
PVmin PVmax	Specification of the reference range for the dead band of the process controller (P.CONTROL → PID.PARAMETER → DBND).	Yes	Yes	Yes
	Specification of the reference range for the analog feedback (option). See chapter "26.2.14. OUTPUT – Configuration of the outputs (option)".	Yes	Yes	Yes
	Sensor calibration:	Yes see "Figure 37"	No	No
K factor	Sensor calibration:	No	No	Yes see "Figure 38"
	Adjustment range:	–	–	0...9999

Table 30: Effects of the settings in PV-SCALE depending on the signal type selected in PV-INPUT

Example of a sensor calibration for the 4 - 20 mA signal type:

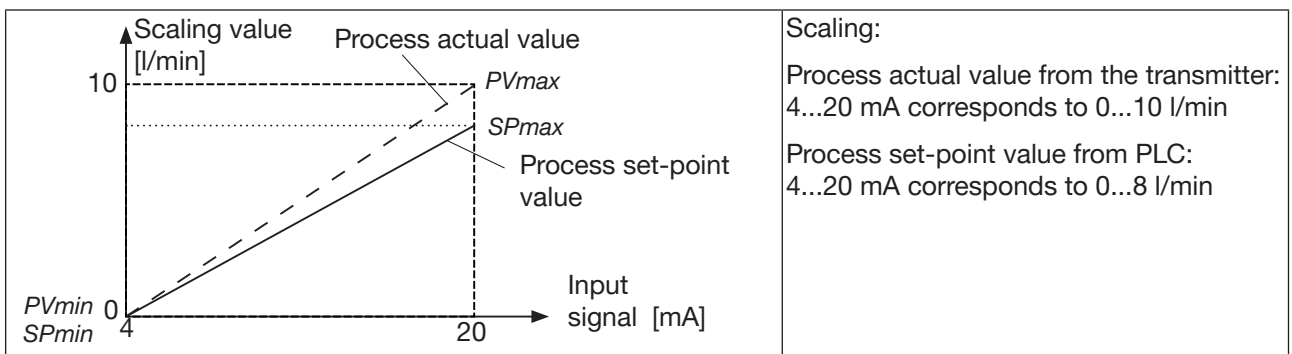


Figure 27: Example of a sensor calibration for the 4 - 20 mA signal type

MAN 1000341264 EN Version: C Status: RL (released | freigegeben) printed: 09.12.2019

**!** For internal set-point value default (*SP-INPUT* → *internal*), the process set-point value is input directly on the process level.

Example of a sensor calibration for *frequency* signal type:

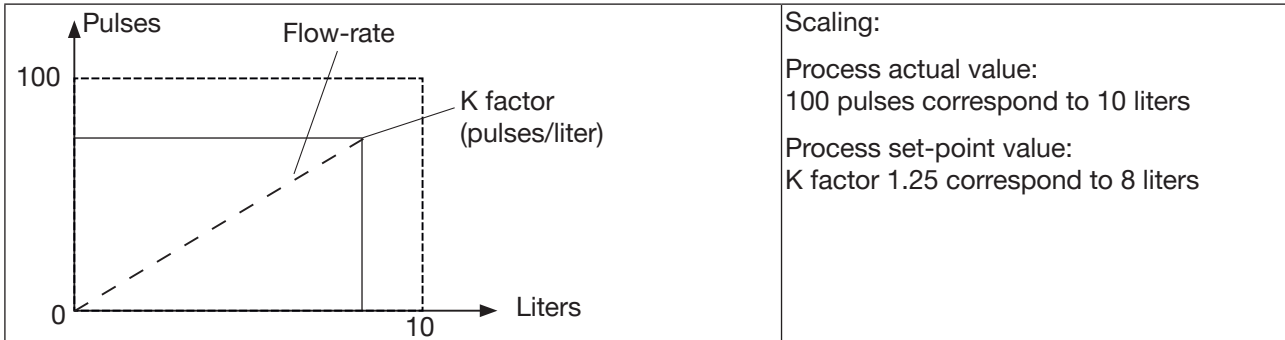


Figure 28: Example of a sensor calibration for frequency signal type

Scale the process actual value in the menu as follows:

- ▲ / ▼ Select **PV-SCALE**. Selection in the main menu (MAIN).
- Select **ENTER**. The submenu options for scaling of the process actual value are displayed.
- ✔ You have scaled the process actual value.

**PVmin** is set as follows:

- ▲ / ▼ Select **PVmin**.
- Select **INPUT**. The input screen is opened.  
First specify the physical unit which has a dark background.
- ▲ Select **+**. Select physical unit.
- ▼ Select **<-** decimal point. The decimal point has a dark background.
- ▲ Select **+**. The last digit of the scaling value has a dark background.
- ▼ Select **<-** scaling value. The last digit of the scaling value has a dark background.
- ▲ / ▼ **+** Increase value and **<-** select decimal place.  
Set scaling value (lower process actual value).
- Select **OK**. Return to **PV-SCALE**.

✔ You have set the PVmin.

**PVmax** is set as follows:

- ▲ / ▼ Select **PVmax**.
- Select **INPUT**. The input screen is opened.  
The last digit of the scaling value has a dark background.
- ▲ / ▼ **+** Increase value and **<-** select decimal place.  
Set scaling value (lower process actual value).
- Select **OK**. Return to **PV-SCALE**.

✔ You have set the PVmax.



### Set the *K* factor as follows:

→ ▲ / ▼ Select *K* factor.

→  Select **ENTER**. The submenu options for scaling of the process actual value are displayed.

### Either:

→ ▲ / ▼ Select *VALUE*. Manual input of the *K* factor.

→  Select **INPUT**. The input screen is opened. The decimal point has a dark background.

→ ▲ Select **+**. Specify position of the decimal point.

→ ▼ Select **<-** the value. The last digit of the value has a dark background.

→ ▲ / ▼ **+** Increase value and **<-** select decimal place.  
Set *K* factor.

→  Select **OK**. Return to *K* factor.


### Or:

→ ▲ / ▼ Select *TEACH-IN*. Calculating the *K* factor by measuring a specific flow rate.

→  Select **INPUT**. The input screen is opened. The decimal point has a dark background.

→  Select **ENTER**, hold down for 5 s. Valve closes.

→  Select **START**. The container is being filled.

→  Select **STOP**. The measured volume is displayed and the input screen is opened.  
The decimal point has a dark background.

→ ▲ **+** Select decimal point. Specify position of the decimal point.

→ ▼ **<-** Select the value. The last digit of the value has a dark background.

→ ▲ Select **+**. The last digit of the scaling value has a dark background.

→ ▲ / ▼ **+** Increase value and **<-** select decimal place.  
Set the measured volume.

→  Select **OK**. Return to *TEACH-IN*.

→  Select **EXIT**. Return to *K* factor.

→  Select **EXIT**. Return to *PV-SCALE*.

→  Select **EXIT**. Return to *SETUP*.

✓ You have set the *K* factor.






If the submenu is left by pressing the left selection key **ESC**, the value remains unchanged.

### 15.2.3 SP-INPUT – Type of set-point value default (internal or external)

The SP-INPUT menu specifies how the default of the process set-point value is to be implemented.

- Internal: Input of the set-point value on the process level
- External: Default of the set-point value via the standard signal input

Set the type of set-point value default as follows:

- ▲ / ▼ Select **SP-INPUT**
-  Select **ENTER**. The types of set-point value default are displayed.
- ▲ / ▼ Select the type of set-point value default.
-  Select **SELECT**. The selection is marked by a filled circle ●.
-  Select **EXIT**. Return to **SETUP**.
- ✔ You have set the type of set-point value default.



For internal set-point value default (*SP-INPUT* → *internal*), the process set-point value is input directly on the process level.

### 15.2.4 SP-SCALE – Scaling of the process set-point value (for external set-point value default only)

The *SP-SCALE* menu assigns the values for the lower and upper process set-point value to the particular current or voltage value of the standard signal.





The menu is available for external set-point value default only (*SP-INPUT* → *external*).





For internal set-point value default (*SP-INPUT* → *internal*), there is no scaling of the process set-point value via *SPmin* and *SPmax*.

The set-point value is entered directly on the process level. The physical unit and the position of the decimal point are specified during the scaling of the process actual value (*PV-SCALE* → *PVmin*). For a description see chapter “25.2.2. *PV-SCALE*– Scaling of the process actual values” on page 86.

Scale the process set-point value as follows:

- ▲ / ▼ Select **SP-SCALE**
-  Select **ENTER**. The submenu options for scaling of the process set-point value are displayed.
- ▲ / ▼ Select **SPmin**.
-  Select **INPUT**. The input screen is opened.
- ▲ / ▼ **+** Increase value and **<-** select decimal place.  
Set scaling value (lower process set-point value). The value is assigned to the smallest current or voltage value of the standard signal.
-  Select **OK**. Return to **SP-SCALE**.
- ▲ / ▼ Select **SPmax**.
-  Select **INPUT**. The input screen is opened.

- ▲ / ▼ **+** Increase value and **<-** select decimal place.  
Set scaling value (upper process set-point value). The value is assigned to the largest current or voltage value of the standard signal.
-  Select **OK**. Return to *SP-SCALE*.
-  Select **EXIT**. Return to *SETUP*.
- ✔ You have scaled the process set-point value.






If the submenu is left by pressing the left selection key **ESC**, the value remains unchanged.

### 15.2.5 *P.CO-INIT* – Smooth switchover MANUAL-AUTOMATIC

The smooth switchover between the MANUAL and AUTOMATIC operating states can be activated or deactivated in the *P.CO-INIT* menu.

Factory default setting:  Smooth switchover activated.

Activate the smooth switchover of the operating states as follows:

- ▲ / ▼ Select *P.CO-INIT*
-  Select **ENTER**. The function (*bumpless*) and (*standard*) is displayed.
- ▲ / ▼ Select required function.  
*bumpless* = smooth switchover activated  
*standard* = smooth switchover deactivated
-  Select **SELECT**. The selection is marked by a filled circle ●.
-  Select **EXIT**. Return to *SETUP*.
- ✔ You have switched over the operating states.

## 15.3 PID.PARAMETER – Parameterizing the process controller

The following control parameters of the process controller are manually set in this menu.

<b>DBND</b> 1.0%	Insensitivity range (dead band) of the process controller
<b>KP</b> 1.00	Amplification factor of the (P portion of the PID controller)
<b>TN</b> 999.0	Reset time (I portion of the PID controller)
<b>TV</b> 0.0	Hold-back time (D portion of the PID controller)
<b>X0</b> 0.0%	Operating point
<b>FILTER</b> 0	Filtering of the process actual value input



The automatic parameterization of the PID controller integrated in the process controller (menu options **KP**, **TN**, **TV**) can be implemented with the aid of the **P.TUNE** function (see chapter “25.5. P.TUNE – Self-optimization of the process controller”).



Basic information for setting the process controller can be found in chapters “40. Properties of PID controllers” and “41. Adjustment rules for PID controllers”.

### 15.3.1 DBND – Insensitivity range (dead band)

This function causes the process controller to respond from a specific control difference only. This protects both the solenoid valves in Type 8792, 8793 and the pneumatic actuator.

Factory setting: 1.0% with reference to the range of the scaled process actual value (setting in the menu **PV-SCALE** → **PVmin** → **PVmax**).

Enter the parameters as follows:

- ▲ / ▼ Select **PID.PARAMETER**.
- Select **ENTER**. The menu for parameterizing the process controller is displayed.
- ▲ / ▼ Select *menu option*.
- Select **INPUT**. The input screen is opened.
- ▲ / ▼ **+** Increase value and **-** reduce value  
Set value at
- \* 

<b>DBND</b> X.X%	/	<b>X0</b> 0%	/	<b>FILTER</b> 5
------------------	---	--------------	---	-----------------
- Select **OK**. Return to **PID.PARAMETER**.
- Select **EXIT**. Return to **P.CONTROL**.
- Select **EXIT**. Return to the main menu (MAIN).
- Select **EXIT**. Return to **P.CONTROL**. Switching from setting level ⇔ process level.
- ✓ You have set the parameter.



If the submenu is left by pressing the left selection key **ESC**, the value remains unchanged.

Insensitivity range for process control

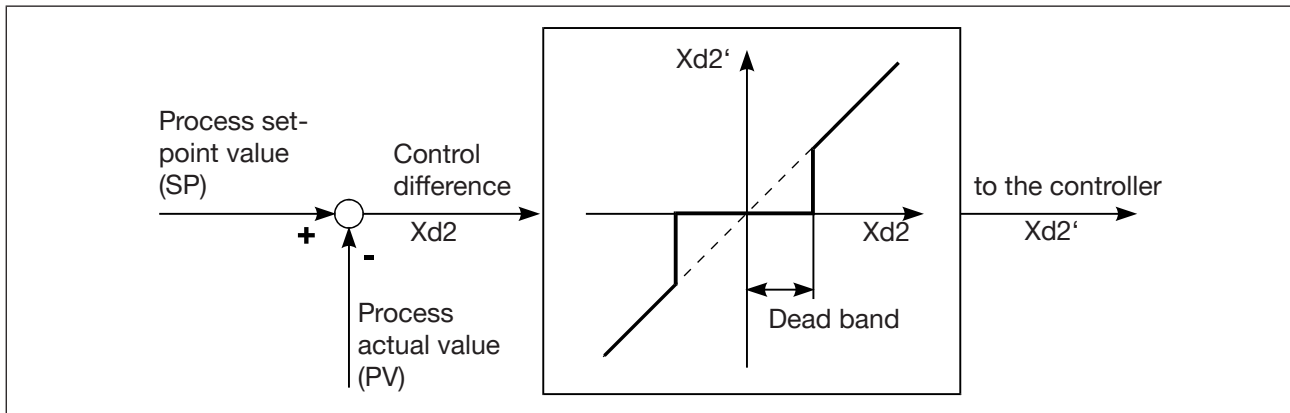


Figure 29: DBND graph; insensitivity range for process control

### 15.3.2 KP – Amplification factor of the process controller

The amplification factor specifies the P portion of the PID controller (can be set with the aid of the *P.TUNE* function).

Factory setting: 1.00

Enter the parameters as follows:

- ▲ / ▼ Select *PID.PARAMETER*.
  - Select **ENTER**. The menu for parameterizing the process controller is displayed.
  - ▲ / ▼ Select *menu option*.
  - Select **INPUT**. The input screen is opened.
  - ▲ / ▼ **<-** Select decimal place and **+** increase value  
Set value at
- |             |      |   |           |         |   |           |         |
|-------------|------|---|-----------|---------|---|-----------|---------|
| * <i>KP</i> | X.XX | / | <i>TN</i> | X.0 sec | / | <i>TV</i> | 1.0 sec |
|-------------|------|---|-----------|---------|---|-----------|---------|
- Select **OK**. Return to *PID.PARAMETER*.
  - Select **EXIT**. Return to *P.CONTROL*.
  - Select **EXIT**. Return to the main menu (MAIN).
  - Select **EXIT**. Return to *P.CONTROL*. Switching from setting level ⇔ process level.
  - ✔ You have set the parameter.

If the submenu is left by pressing the left selection key **ESC**, the value remains unchanged.

The *KP* amplification of the process controller refers to the scaled, physical unit.

MAN 1000341264 EN Version: C Status: RL (released | freigegeben) printed: 09.12.2019

### 15.3.3 TN – Reset time of the process controller

The reset time specifies the I portion of the PID controller, can be set with the *P.TUNE* function.

Factory setting: 999.9 s



Enter the parameters as follows:

→ ▲ / ▼ Select *PID.PARAMETER*.

→  Select **ENTER**. The menu for parameterizing the process controller is displayed.


→ ▲ / ▼ Select *menu option*.

→  Select **INPUT**. The input screen is opened.


→ ▲ / ▼  Select decimal place and  increase value

Set value at 


<i>TN</i>	999.9
-----------	-------

→  Select **OK**. Return to *PID.PARAMETER*.

→  Select **EXIT**. Return to *P.CONTROL*.

→  Select **EXIT**. Return to the main menu (MAIN).

→  Select **EXIT**. Return to *P.CONTROL*. Switching from setting level ⇔ process level.

 You have set the parameter.



If the submenu is left by pressing the left selection key **ESC**, the value remains unchanged.

### 15.3.4 TV – Hold-back time of the process controller

The hold-back time specifies the D portion of the PID controller (can be set with the aid of the *P.TUNE* function).


Factory setting: 0.0 s


Enter the parameters as follows:

→ ▲ / ▼ Select *PID.PARAMETER*.

→  Select **ENTER**. The menu for parameterizing the process controller is displayed.

→ ▲ / ▼ Select *menu option*.

→  Select **INPUT**. The input screen is opened.

→ ▲ / ▼  Select decimal place and  increase value


Set value at 


<i>TV</i>	0.0
-----------	-----

→  Select **OK**. Return to *PID.PARAMETER*.

→  Select **EXIT**. Return to *P.CONTROL*.

→  Select **EXIT**. Return to the main menu (MAIN).

→  Select **EXIT**. Return to *P.CONTROL*. Switching from setting level ⇔ process level.

 You have set the parameter.



If the submenu is left by pressing the left selection key **ESC**, the value remains unchanged.

### 15.3.5 X0 – Operating point of the process controller

The operating point corresponds to the operating point of the proportional portion when control difference = 0.


Factory setting: 0.0%

Enter the parameters as follows:

→ ▲ / ▼ Select *PID.PARAMETER*.


→  Select **ENTER**. The menu for parameterizing the process controller is displayed.

→ ▲ / ▼ Select *menu option*.

→  Select **INPUT**. The input screen is opened.


→ ▲ / ▼ **+** Increase value and **-** reduce value

Set value at

→  Select **OK**. Return to *PID.PARAMETER*.

→  Select **EXIT**. Return to *P.CONTROL*.

→  Select **EXIT**. Return to the main menu (MAIN).

→  Select **EXIT**. Return to *P.CONTROL*. Switching from setting level ⇔ process level.

✓ You have set the parameter.



If the submenu is left by pressing the left selection key **ESC**, the value remains unchanged.

### 15.3.6 FILTER – Filtering of the process actual value input

The filter is valid for all process actual value types and has a low-pass behavior (PT1).

Factory setting: 0

Enter the parameters as follows:

→ ▲ / ▼ Select *PID.PARAMETER*.

→  Select **ENTER**. The menu for parameterizing the process controller is displayed.

→ ▲ / ▼ Select *menu option*.



→  Select **INPUT**. The input screen is opened.


→ ▲ / ▼ **+** Increase value and **-** reduce value

Set value at

→  Select **OK**. Return to *PID.PARAMETER*.

→  Select **EXIT**. Return to *P.CONTROL*.


-  Select **EXIT**. Return to the main menu (MAIN).
-  Select **EXIT**. Return to *P.CONTROL*. Switching from setting level ⇔ process level.
- ✓ You have set the parameter.

 If the submenu is left by pressing the left selection key **ESC**, the value remains unchanged.

### Setting the filter effect in 10 stages

Setting	Corresponds to limit frequency (Hz)	Effect
0	10	Lowest filter effect
1	5	
2	2	
3	1	
4	0.5	
5	0.2	
6	0.1	
7	0.07	
8	0.05	
9	0.03	

Table 31: Setting the filter effect

 On [Page 92](#) you will find a table for entering your set parameters.

## 15.4 P.Q'LIN – Linearization of the process characteristic



This function automatically linearizes the process characteristic.

In doing so, the nodes for the correction characteristic are automatically determined. To do this, the program moves through the valve stroke in 20 steps and measures the associated process variable.

The correction characteristic and the associated value pairs are saved in the menu option *CHARACT* → *FREE*. This is where they can be viewed and freely programmed. For a description see chapter “26.2.1.”.

If the *CARACT* menu option has still not been activated and incorporated into the main menu (MAIN), this will happen automatically when *P.Q'LIN* is being run.

Run the *P.Q'LIN* as follows:

-  Select *P.Q'LIN*. The function is in the main menu (MAIN) after activation of *P.CONTROL*.
-  Select **RUN**. Hold down as long as countdown (5 ...) is running. *P.Q'LIN* is started.

The following displays are indicated on the display:

Q'LIN #0  
CMD=0%

Q.LIN #1  
CMD=10%

... continuing to



Q.LIN #10  
CMD=100%

Display of the node which is currently running (progress is indicated by a progress bar along the upper edge of the display).

Q.LIN  
ready

Automatic linearization was successfully completed.

→ Select **EXIT**. Return to the main menu (MAIN).

You have set the parameter.

**Possible error messages when running P.Q'LIN:**

Display	Cause of error	Remedy
Q.LIN err/break	Manual termination of linearization by pressing the <b>EXIT</b> key.	
P.Q'LIN ERROR 1	No supply pressure connected.	Connect supply pressure.
	No change to process variable.	Check process and, if required, switch on pump or open the shut-off valve. Check process sensor.
P.Q'LIN ERROR 2	Failure of the supply pressure while P.Q'LIN running.	Check supply pressure.
	Automatic adjustment of the X.TUNE position controller not run.	Run X.TUNE.

Table 32: P.Q'LIN; possible error messages

## 15.5 P.TUNE – Self-optimization of the process controller

This function can be used to automatically parameterize the PID controller integrated in the process controller.

In doing so, the parameters for the P, I and D portion of the PID controller are automatically determined and transferred to the corresponding menus of (KP, TN, TV). This is where they can be viewed and changed.

### Explanation of the PID controller:

The control system of Type 8793 has an integrated PID process controller. Any process variable, such as flow rate, temperature, pressure, etc., can be controlled by connecting an appropriate sensor.

To obtain good control behavior, the structure and parameterization of the PID controller must be adjusted to the properties of the process (controlled system).

This task requires control experience as well as measuring instruments and is time-consuming. The P.TUNE function can be used to automatically parameterize the PID controller integrated in the process controller.



Basic information for setting the process controller can be found in chapters [“40. Properties of PID controllers”](#) and [“41. Adjustment rules for PID controllers”](#).

### 15.5.1 The operating mode of *P.TUNE*

The *P.TUNE* function automatically identifies the process. To do this, the process is activated with a defined disturbance variable. Typical process characteristics are derived from the response signal and the structure and parameters of the process controller are determined on the basis of the process characteristics.

When using *P.TUNE* self-optimization, optimum results are obtained under the following conditions:

- Stable or stationary conditions concerning the process actual value *PV* when starting *P.TUNE*.
- Execution of *P.TUNE* in the operating point or within the operating range of the process control.

### 15.5.2 Preparatory measures for execution of *P.TUNE*




The measures described below are not compulsory conditions for running the *P.TUNE* function. However, they will increase the quality of the result.

The *P.TUNE* function can be run in the MANUAL or AUTOMATIC operating state.

When *P.TUNE* is complete, the control system is in the operating state which was set previously.

#### 15.5.2.1. Preparatory measure for execution of *P.TUNE* in the MANUAL operating state

Move the process actual value up to the operating point as follows:

- ▲ / ▼ Select *PV*. The process actual value *PV* is indicated on the display.
-  Select **MANU**. Change to MANUAL operating state.  
The input screen for manually opening and closing the valve is displayed.
- ▲ Open valve **OPN** or ▼ close valve **CLS**  
By opening or closing the control valve, move the process actual value to the required operating point.
- As soon as the process actual value *PV* is constant, the *P.TUNE* function can be started.
- ✔ You have moved the process actual value *PV* to the operating point.

#### 15.5.2.2. Preparatory measure for execution of *P.TUNE* in the AUTOMATIC operating state

By inputting a process set-point value *SP*, move the process actual value *PV* to the operating point.



Observe the internal or external set-point value default for the input (*P,CONTROL* → *SETUP* → *SP-INPUT* → *internal/external*):

For internal set-point value default: Input the process set-point value *SP* via the device keyboard (see description below "[Table 50](#)").

For external set-point value default: Input the process set-point value *SP* via the analog set-point value input.

Enter the process set-point value as follows: ( **Setting on the process level** )

→ ▲ / ▼ Select **SP**. The process set-point value is indicated on the display.

→  Select **INPUT**. The input screen for inputting the process set-point value is displayed.

→ ▲ / ▼ Enter value  Select decimal place  
 Increase value

The selected set-point value *SP* should be near the future operating point.

→  Select **OK**. Acknowledge input and return to the display of *SP*.

✓ You have entered the process actual value.

The process variable *PV* is changed according to the set-point value default based on the factory default PID parameters.

→ Before running the *P.TUNE* function, wait until the process actual value *PV* has reached a stable state.



To observe *PV*, it is recommended to select via the arrow keys ▲ / ▼ the graphical display *SP/PV(t)*.

To be able to select the display *SP/PV(t)* it must be activated in the EXTRAS menu (see chapter "16.1.20 EXTRAS – Setting the display").

→ If *PV* oscillates continuously, the preset amplification factor of the process controller *KP* in the menu *P.CONTROL* → *PID.PARAMETER* should be reduced.

→ As soon as the process actual value *PV* is constant, the *P.TUNE* function can be started.

### 15.5.3 Starting the function *P.TUNE*



#### WARNING

**Risk of injury from uncontrolled process.**


While the *P.TUNE* function is running, the control valve automatically changes the current degree of opening and intervenes in the running process.

- ▶ Using suitable measures, prevent the permitted process limits from being exceeded.  
 For example by:
  - an automatic emergency shutdown
  - stopping the *P.TUNE* function by pressing the STOP key (press left or right key).

Set the *P.TUNE* function as follows:

→  Press **MENU** for 3 s. Switching from process level ⇒ setting level.

→ ▲ / ▼ Select *P.TUNE*.

→  Select **RUN**. Hold down as long as countdown (5 ...) is running.

During the automatic adjustment the following messages are indicated on the display.

"starting process tune" - Start self-optimization.

"identifying control process" - Process identification. Typical process variables are determined from the response signal to a defined stimulus.

"calculating PID parameters" - Structure and parameters of the process controller are determined.

"TUNE ready" - Self-optimization was successfully completed.

→ Press any key. Return to the main menu (MAIN).

→  Select **EXIT**. Switching from setting level ⇒ process level.

✓ You have set the P.TUNE function.

! To stop *P.TUNE*, press the left or right selection key **STOP**.

! The changed data is saved in the memory (EEPROM) only when there is a switch to the process level, by leaving the main menu (MAIN) using the left selection key **EXIT**.

**Possible error messages when running *P.TUNE*:**

Display	Cause of error	Remedy
<i>TUNE</i> <i>err/break</i>	Manual termination of self-optimization by pressing the <b>EXIT</b> key.	
<i>P.TUNE</i> <i>ERROR 1</i>	No supply pressure connected.	Connect supply pressure.
	No change to process variable.	Check process and, if required, switch on pump or open the shut-off valve. Check process sensor.

Table 33: *P.TUNE*; possible error messages

After making all the settings described in chapter “[Start-up](#)”, the process controller is ready for operation.

Activation and configuration of auxiliary functions is described in the following chapter “[26. Configuring the auxiliary functions](#)”.

## 16 AUXILIARY FUNCTIONS

The device has auxiliary functions for demanding control tasks.

This chapter describes how the auxiliary functions are activated, set and configured.

Overview and description of the auxiliary functions:

ADD.FUNCTION	Description
<i>CHARACT</i>	Selection of the transfer characteristic between input signal and stroke (correction characteristic)
<i>CUTOFF</i>	Sealing function for position controller
<i>DIR.CMD</i>	Effective direction between input signal and set-point position
<i>DIR.ACT</i>	Assignment of the aeration state of the actuator chamber to the actual position
<i>SPLTRNG *</i>	Signal split range; input signal as a% for which the valve runs through the entire stroke range.
<i>X.LIMIT</i>	Limit of the mechanical stroke range
<i>X.TIME</i>	Limit of the control speed
<i>X.CONTROL</i>	Parameterization of the position controller
<i>P.CONTROL</i>	Parameterization of the process controller
<i>SECURITY</i>	Code protection for settings
<i>SAFEPOS</i>	Input the safety position
<i>SIG.ERROR</i>	Configuration of signal level fault detection
<i>BINARY.IN</i>	Activation of the digital input
<i>OUTPUT</i>	Configuration of outputs (option)
<i>CAL.USER</i>	Calibration
<i>SET.FACTORY</i>	Reset to factory settings
<i>SERVICE.BUES</i>	Configuring the bÜS service interface
<i>EXTRAS</i>	Setting the display
<i>POS.Sensor</i>	Setting interface remote position sensor (available for Type 8793 Remote only)
<i>SERVICE</i>	For internal use only
<i>SIMULATION</i>	Simulation of set-point value, process valve, process
<i>DIAGNOSE</i>	Diagnostic menu (option)

\* The *SPLTRNG* auxiliary function can only be selected if *P.CONTROL* (process control) is not activated.

Figure 30: Overview - auxiliary functions








## 16.1 Activating and deactivating auxiliary functions

The required auxiliary functions must be activated by the user initially by incorporation into the main menu (MAIN). The parameters for the auxiliary functions can then be set.






To deactivate a function, remove it from the main menu. This will cause the previous settings, created under this function, to be rendered invalid again.

### 16.1.1 Including auxiliary functions in the main menu

Add auxiliary functions to ADD.FUNCTION as follows:

-  Press **MENU** for 3 s. Switching from process level ⇒ setting level.
  -  Select *ADD.FUNCTION*.
  -  Select **ENTER**. The possible auxiliary functions are displayed.
  -  Select required auxiliary function
  -  Select **ENTER**. The selected auxiliary function is now marked by a cross ☒.
  -  Select **EXIT**. Acknowledgment and simultaneous return to the main menu (MAIN).  
The marked function is now activated and incorporated into the main menu.
-  You have added the auxiliary functions.

Set the parameters of the auxiliary functions as follows:

-  Select auxiliary function. In the main menu (MAIN) select the auxiliary function.
  -  Select **ENTER**. Opening the submenu to input the parameters.  
Further information about the setting can be found in the following chapter [“16 Auxiliary functions”](#).
  -  Select **EXIT** \* or **ESC** \*. Return to a higher level or to the main level (MAIN).
  -  Select **EXIT**. Switching from setting level ⇒ process level.
-  You have parameterized the auxiliary functions.

\* The designation of the key depends on the selected auxiliary function.







The changed data is saved in the memory (EEPROM) only when there is a switch to the process level, by leaving the main menu (MAIN) using the left selection key **EXIT**.

## 16.1.2 Removing auxiliary functions from the main menu



If a function is removed from the main menu, the settings implemented previously under this function become invalid again.

Remove auxiliary functions from **ADD.FUNCTION** as follows:

-  Press **MENU** for 3 s. Switching from process level ⇒ setting level.
- ▲ / ▼ Select **ADD.FUNCTION**.
-  Select **ENTER**. The possible auxiliary functions are displayed.
- ▲ / ▼ Select auxiliary function
-  Select **ENTER**. Remove function mark (no cross ).
-  Select **ENTER**. Acknowledgment and simultaneous return to the main menu (MAIN).  
The marked function is now deactivated and removed from the main menu.

✓ You have removed the auxiliary functions.

## 16.1.3 CHARACT – Selection of the transfer characteristic between input signal (set-point position) and stroke

Characteristic (customer-specific characteristic)





Use this auxiliary function to select a transfer characteristic with reference to set-point value (set-point position, *CMD*) and valve stroke (*POS*) for correction of the flow or operating characteristics.

Factory setting: *linear*



Each auxiliary function, which is to be set, must be incorporated initially into the main menu (MAIN). See chapter “26.1. Activating and deactivating auxiliary functions” on page 102.

Enter the freely programmable characteristic as follows:

-  Press **MENU** for 3 s. Switching from process level ⇒ setting level.
- ▲ / ▼ Select **CHARACT**. (To do this, the auxiliary function must be incorporated into the main menu).
-  Select **ENTER**. Menu options of **CHARACT** are displayed.
- ▲ / ▼ **linear** (linear characteristic)
  - GP 1:25: Equal percentage characteristic 1:25
  - GP 1:33: Equal percentage characteristic 1:33
  - GP 1:50: Equal percentage characteristic 1:50
  - GP 25:1: Inversely equal percentage characteristic 25:1
  - GP 33:1: Inversely equal percentage characteristic 33:1
  - GP 50:1: Inversely equal percentage characteristic 50:1
  - FREE: \* User-defined characteristic, freely programmable via nodes
-  Select **SELECT**. The selection is marked by a filled circle ●.
-  Select **EXIT**. Switching from setting level ⇒ process level.

The flow characteristic  $k_v = f(s)$  indicates the flow-rate of a valve, expressed by the  $k_v$  value as a function of the stroke  $s$  of the actuator spindle. It is determined by the design of the valve seat and the seat seal. In general two types of flow characteristics are implemented, the linear and the equal percentage.

In the case of linear characteristics, equal  $k_v$  value changes  $dk_v$  are assigned to equal stroke changes  $ds$ .

$$(dk_v = n_{lin} \cdot ds).$$

In the case of an equal percentage characteristic, an equal percentage change of the  $k_v$  value corresponds to a stroke change  $ds$ .

$$(dk_v/k_v = n_{equal\ percentage} \cdot ds).$$

The operating characteristic  $Q = f(s)$  specifies the correlation between the volumetric flow  $Q$  in the installed valve and the stroke  $s$ . This characteristic has the properties of the pipelines, pumps and consumers. It therefore exhibits a form which differs from the flow characteristic.

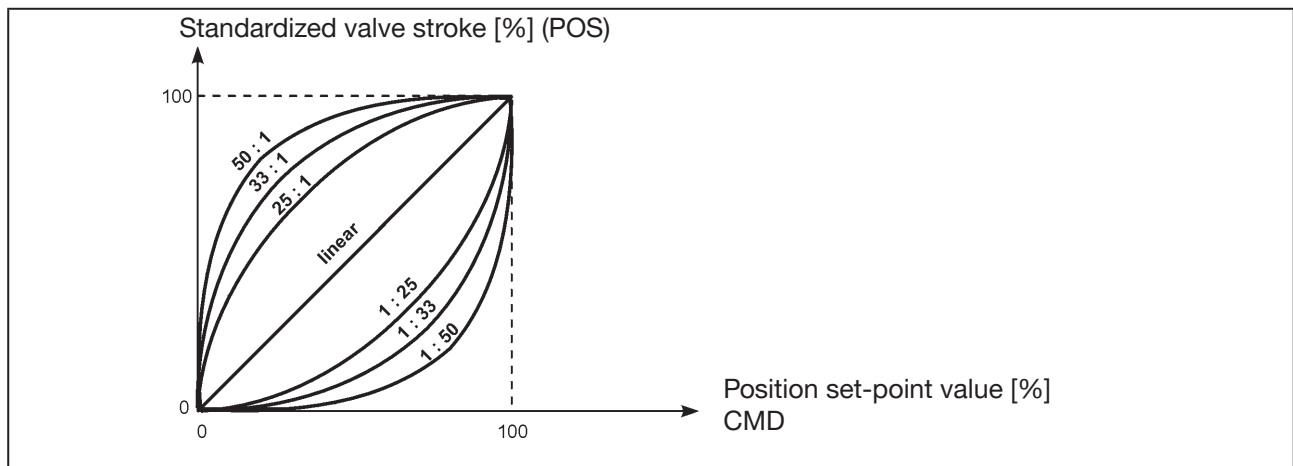


Figure 31: Characteristics

In the case of control tasks for closed-loop control systems it is usually particular demands which are placed on the course of the operating characteristic, e.g. linearity. For this reason it is occasionally necessary to correct the course of the operating characteristic in a suitable way. For this purpose Type 8792/8793 features a transfer element which implements different characteristics. These are used to correct the operating characteristic.






Equal percentage characteristics 1:25, 1:33, 1:50, 25:1, 33:1, and 50:1 and a linear characteristic can be set. Furthermore, a characteristic can be freely programmed via nodes or automatically calibrated.

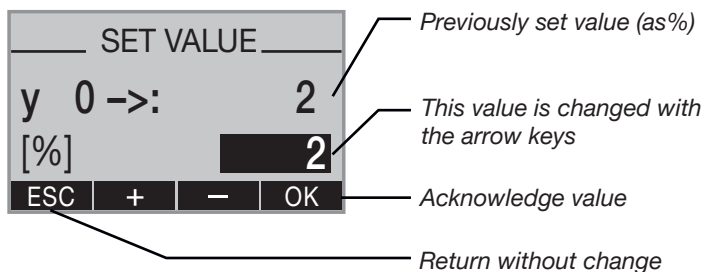
### 16.1.3.1. Entering the freely programmable characteristic







The characteristic is defined via 21 nodes which are distributed uniformly over the position set-point value ranging from 0...100%. They are spaced at intervals of 5%. A freely selectable stroke (adjustment range 0...100%) can be assigned to each node. The difference between the stroke values of two adjacent nodes must not be greater than 20%.




Enter the freely programmable characteristic as follows:

-  Press **MENU** for 3 s. Switching from process level ⇒ setting level.
- ▲ / ▼ Select **CHARACT**. To do this, the auxiliary function must be incorporated into the main menu.
-  Select **ENTER**. Menu options of **CHARACT** are displayed.
- ▲ / ▼ Select **FREE**
-  Select **SELEC**. The graphical display of the characteristic is displayed.
-  Select **INPUT**. Submenu with the individual nodes (as%) is opened.
- ▲ / ▼ Select node.
-  Select **INPUT**.  
The **SET-VALUE** input screen for inputting values is opened.



- ▲ / ▼ Enter value: Enter value for the selected node.
    -  Increase value
    -  Reduce value
  -  Select **OK**. Acknowledge input and return to the **FREE** submenu.
  -  Select **EXIT**. Return to the **CHARACT** menu.
  -  Select **EXIT**. Return to the main menu (**MAIN**).
  -  Select **EXIT**. Switching from setting level ⇒ process level.  
The changed data is saved in the memory (EEPROM).
- ✓ You have entered the freely programmable characteristic.

 The changed data is saved in the memory (EEPROM) only when there is a switch to the process level, by leaving the main menu (**MAIN**) using the left selection key **EXIT**.

Example of a programmed characteristic

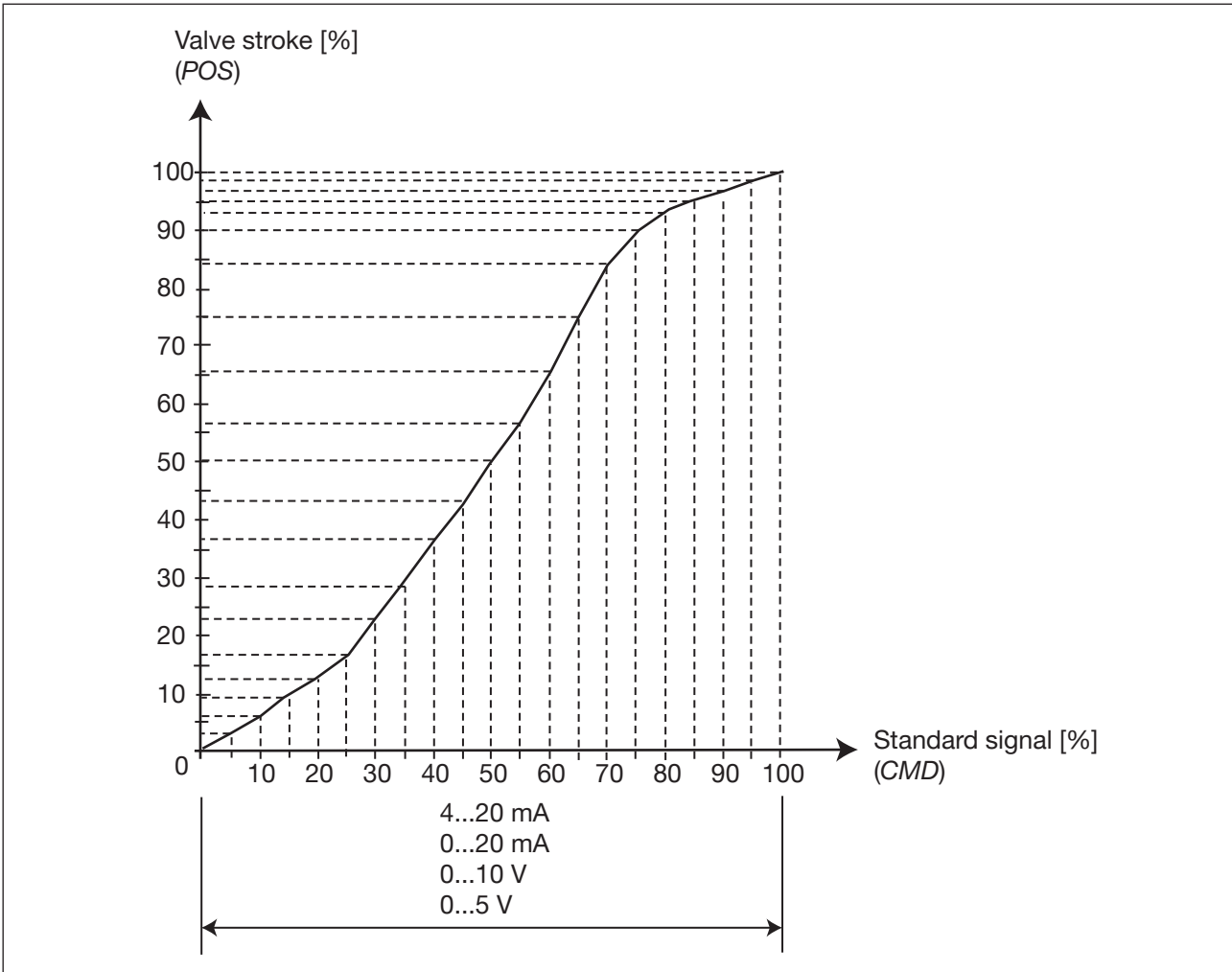


Figure 32: Example of a programmed characteristic



In the section “[Tables for customer-specific settings](#)” in chapter “[42.1. Settings of the freely programmed characteristic](#)” there is a table in which you can enter your settings for the freely programmable characteristic.

## 16.1.4 CUTOFF – Sealing function

This function causes the valve to be sealed outside the control range.

To do this, the limits for the set-point position (*CMD*) are entered as a percentage from which the actuator is fully deaerated or aerated.

Controlled operation opens or resumes at a hysteresis of 1%.

If the process valve is in the sealing area, the message “*CUTOFF ACTIVE*” is indicated on the display.

**Only for Type 8793:** Here you can select the set-point value to which the sealing function is to apply:






*Type PCO* Process set-point value (*SP*)

*Type XCO* Position set-point value (*CMD*)






If *Type PCO* was selected, the limits for the process set-point value (*SP*) are entered as a percentage with reference to the scaling range.


Factory setting: *Min = 0%*; *Max = 100%*; *CUT type = Type PCO*

Enter *CUTOFF* as follows:


-  Press **MENU** for 3 s. Switching from process level ⇒ setting level.
- ▲ / ▼ Select **CUTOFF**. (To do this, the auxiliary function must be incorporated into the main menu).
-  Select **ENTER**. Menu options of *CUTOFF* are displayed.
-  Select **INPUT**.  
The *Min 0%* input screen for inputting values is opened.
- ▲ / ▼ Enter value: Enter value for the selected node.
  - + Increase value
  - Reduce value
-  Select **INPUT**.  
The *Max 100%* input screen for inputting values is opened.
- ▲ / ▼ Enter value: Enter value for the selected node.
  - + Increase value
  - Reduce value
-  Select **OK**. Acknowledge input and return to the *CUTOFF* submenu.  
*\* If the submenu is left by pressing the **ESC** key, the value remains unchanged.*

Or for Type 8793:

-  Select **INPUT**.  
The *CUT type\** input screen for inputting values is opened.  
**\*Available for Type 8793 only**
-  Select **SELEC**. The *Type PCO* input screen for inputting the selection of the process set-point value.
-  Select **SELEC**. The *Type XCO* input screen for inputting the selection of the set-point position.
-  Select **EXIT**. Return to the *CUTOFF* menu.
-  Select **EXIT**. Return to the main menu (MAIN).

→  Select **EXIT**. Switching from setting level ⇒ process level.  
The changed data is saved in the memory (EEPROM).

✔ You have entered the *CUTOFF* sealing function.

 The changed data is saved in the memory (EEPROM) only when there is a switch to the process level, by leaving the main menu (MAIN) using the left selection key **EXIT**.

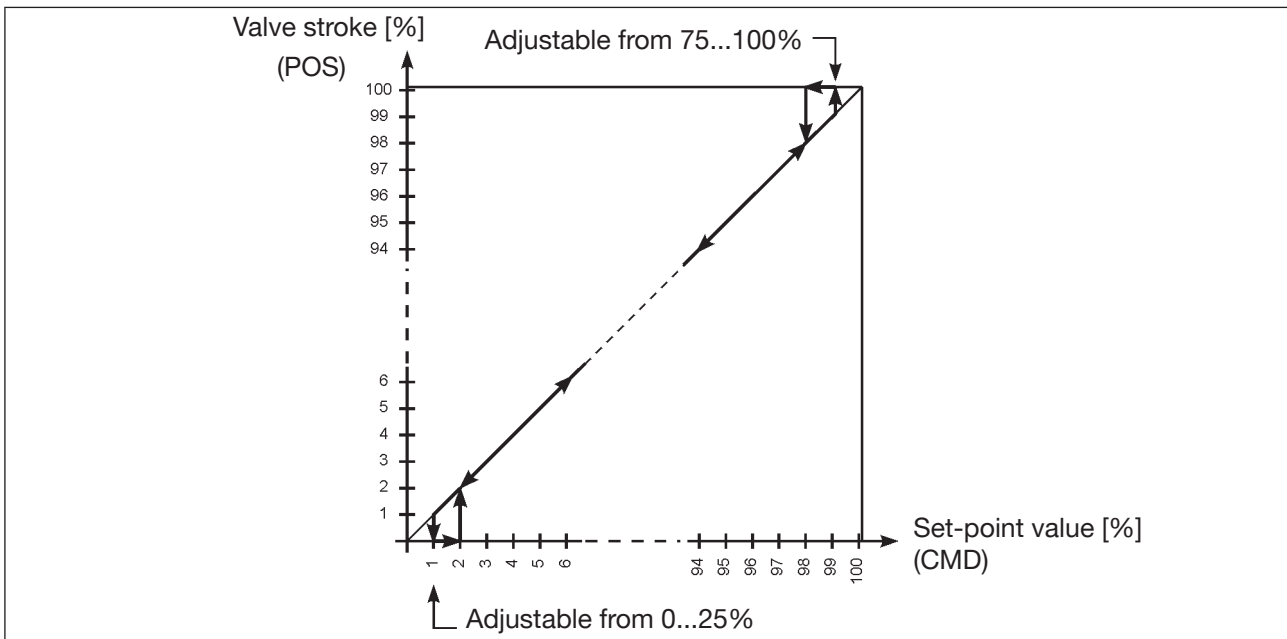


Figure 33: CUTOFF graph


### 16.1.5 DIR.CMD – Effective direction (Direction) of the positioner set-point value

You can use this auxiliary function to set the effective direction between the input signal (*INPUT*) and the set-point position (*CMD*) of the actuator.

**!** Each auxiliary function, which is to be set, must be incorporated initially into the main menu (*MAIN*). See chapter “26.1. Activating and deactivating auxiliary functions”.

Enter the effective direction of the position controller set-point value as follows: (Setting on the process level)

→ ▲ / ▼ Select **DIR.CMD**. The effective direction is indicated on the display.

→  Select **ENTER**. The input screen for inputting the effective direction is displayed.

→ ▲ / ▼ Select **SELEC**. *Rise*: direct effective direction  
 (e.g. 4 mA or 0 V → 0%, 20 mA or 5/10 V → 100%)  
*Fall*: inverse effective direction  
 (e.g. 4 mA or 0 V → 100%, 20 mA or 5/10 V → 0%)  
 The selection is marked by a filled circle ●.

→  Select **EXIT**. Acknowledge input and return to the display of *DIR.CMD*.

✓ You have entered the effective direction of the position controller set-point value.

**!** The changed data is saved in the memory (EEPROM) only when there is a switch to the process level, by leaving the main menu (*MAIN*) using the left selection key **EXIT**.

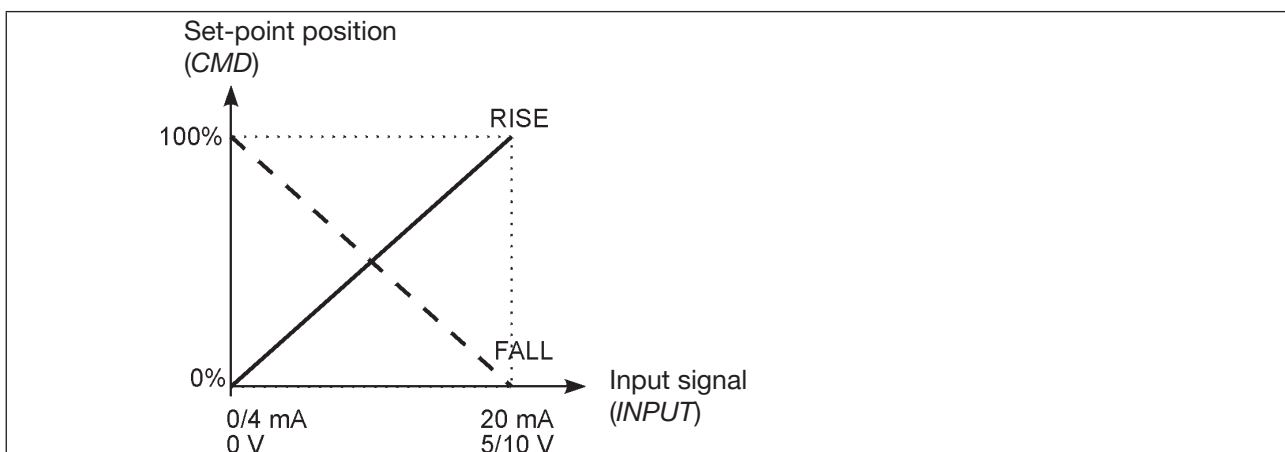


Figure 34: DIR.CMD graph

### 16.1.6 DIR.ACT – Effective direction of the actuating drive

Use this auxiliary function to set the effective direction between the aeration state of the actuator and the actual position (POS).

Factory setting: *Rise*

Enter the effective direction of the actuating drive as follows: (Setting on the process level)

→ ▲ / ▼ Select **DIR.ACT**. The effective direction is indicated on the display.

→  Select **ENTER**. The input screen for inputting the effective direction is displayed.

→ ▲ / ▼ Select **SELEC**. *Rise*: direct effective direction (deaerated → 0%; aerated 100%)  
*Fall*: inverse effective direction (deaerated → 100%; aerated 0%)  
 The selection is marked by a filled circle ●.

→  Select **EXIT**. Acknowledge input and return to the display of **DIR.ACT**.

✔ You have entered the effective direction of the actuating drive.



If the *Fall* function is selected here, the description of the arrow keys (on the display) is changed in the **MANUAL** operating state

**OPN** → **CLS** and **CLS** → **OPN**

The changed data is saved in the memory (EEPROM) only when there is a switch to the process level, by leaving the main menu (**MAIN**) using the left selection key **EXIT**.

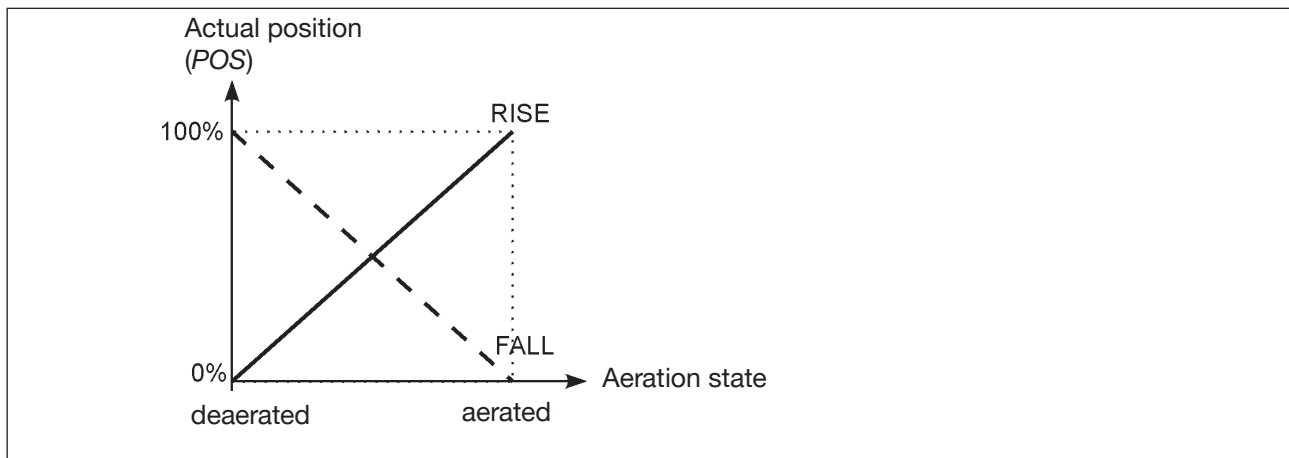


Figure 35: DIR.ACT graph

### 16.1.7 SPLTRNG – Signal split range

Min. and max. values of the input signal as% for which the valve runs through the entire stroke range.

Factory setting:  $Min = 0\%$ ;  $Max = 100\%$



**Type 8793:** The *SPLTRNG* auxiliary function can only be selected when operating as a positioner (position controller).

*P.CONTROL* = not activated.


Use this auxiliary function to limit the position set-point value range of Type 8792/8793 by specifying a minimum and a maximum value.


As a result, it is possible to split a used standard signal range (4...20 mA, 0...20 mA, 0...10 V or 0...5 V) over several devices (without or with overlapping).

This allows several valves to be used **alternately** or, in the case of overlapping set-point value ranges, **simultaneously** as actuators.

**Enter the signal split range as follows: ( Setting on the process level)**


→ ▲ / ▼ Select *SPLTRNG*. The effective direction is indicated on the display.

→  Select **ENTER**. The input screen for inputting the effective direction is displayed.

→  Select **INPUT**.  
The *Min* 0% input screen for inputting values is opened.

→ ▲ / ▼ Enter value: Enter the minimum value of the input signal as%. Adjustment range: 0...75%

+ Increase value  
- Reduce value

→  Select **INPUT**.  
The *Max* 100% input screen for inputting values is opened.

→ ▲ / ▼ Enter value: Input the maximum value of the input signal as%.

Adjustment range: 25...100%

+ Increase value  
- Reduce value

→  Select **OK** \*. Acknowledge input and return to the display of *SPLTRNG*.

✓ You have entered the signal split range.

\* If the submenu is left by pressing the **ESC** key, the value remains unchanged.



The changed data is saved in the memory (EEPROM) only when there is a switch to the process level, by leaving the main menu (MAIN) using the left selection key **EXIT**.

### Splitting a standard signal range into two set-point value ranges

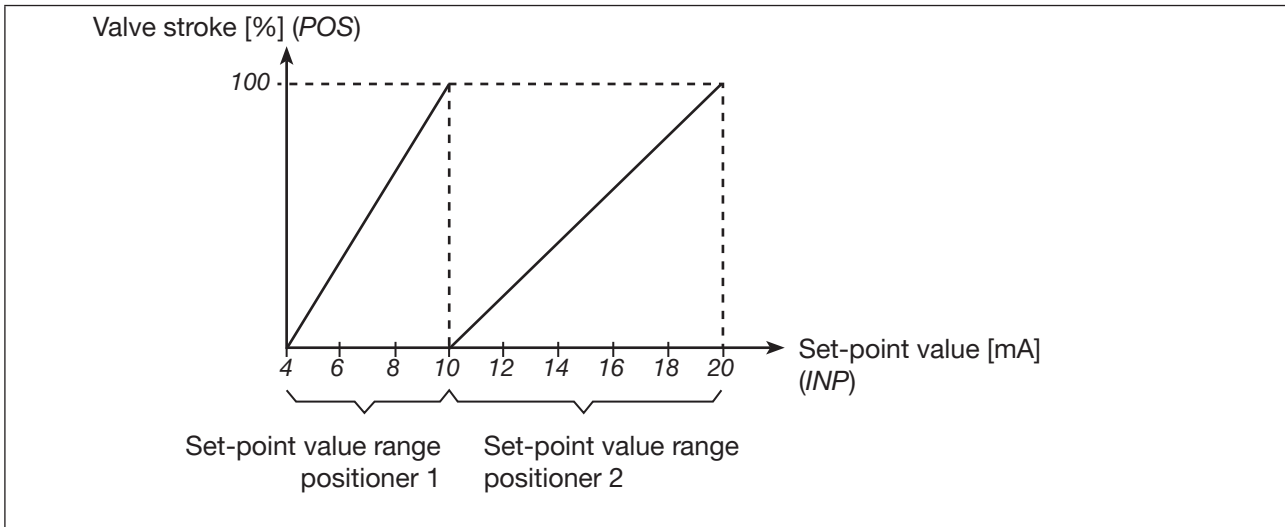


Figure 36: SPLTRNG graph

### 16.1.8 X.LIMIT – Limit of the mechanical stroke range

This auxiliary function limits the (physical) stroke to specified percentage values (minimum and maximum). In doing so, the stroke range of the limited stroke is set equal to 100%.

If the limited stroke range is left during operation, negative POS values or POS values greater than 100% are indicated.

Factory setting: *Min* = 0%, *Max* = 100%

Enter the limit of the mechanical stroke range as follows: ( **Setting on the process level** )

- ▲ / ▼ Select **X.LIMIT**. The limit of the mechanical stroke range is indicated on the display.
- Select **ENTER**. The input screen for inputting the mechanical stroke range is displayed.
- Select **INPUT**.  
The *Min* 0% input screen for inputting values is opened.
- ▲ / ▼ Enter value: Input the initial value of the stroke range as%.  
Adjustment range: 0...50% of the total stroke
  - Increase value
  - Reduce value
- Select **INPUT**.  
The *Max* 100% input screen for inputting values is opened.
- ▲ / ▼ Enter value: Input the final value of the stroke range as%.  
Adjustment range: 50...100% of the total stroke
  - Increase value
  - Reduce value
- Select **OK** \*. Acknowledge input and return to the display of **X.LIMIT**.  
The minimum gap between *Min* and *Max* is 50%

You have entered the limit of the mechanical stroke range.

\* If the submenu is left by pressing the ESC key, the value remains unchanged.



**!** The changed data is saved in the memory (EEPROM) only when there is a switch to the process level, by leaving the main menu (MAIN) using the left selection key **EXIT**.

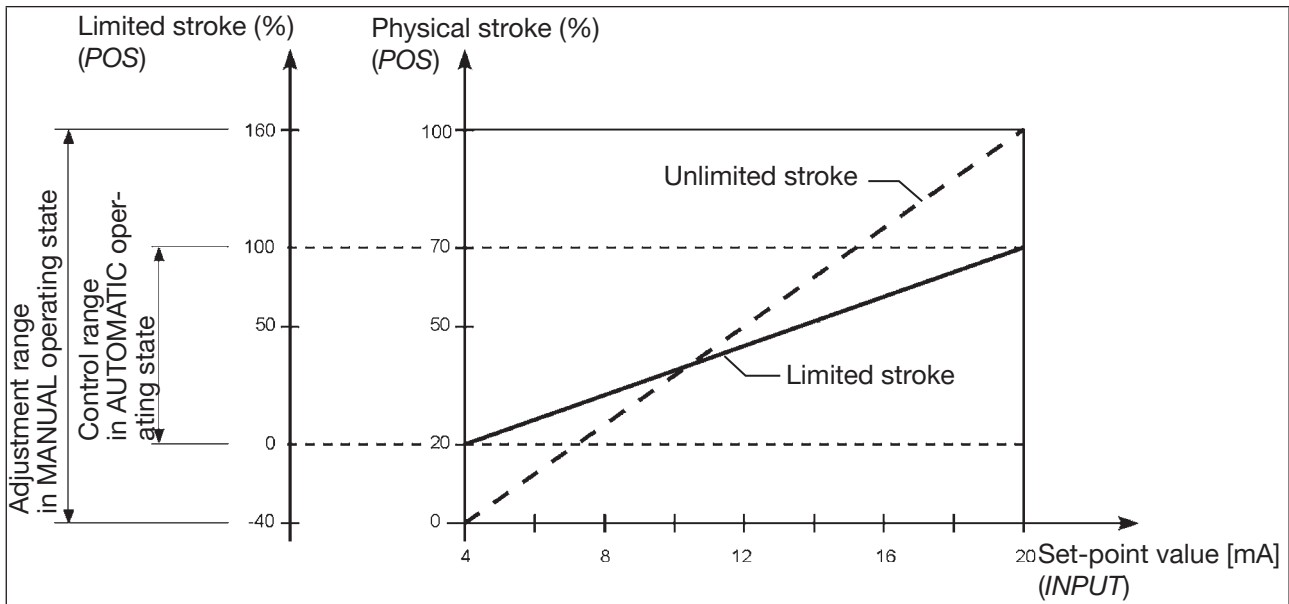


Figure 37: X.LIMIT graph

### 16.1.9 X.TIME – Limit of the control speed

Use this auxiliary function to specify the opening and closing times for the entire stroke and limit the control speeds.

**!** When the X.TUNE function is running, the minimum opening and closing time for the entire stroke is automatically entered for *Open* and *Close*. Therefore, movement can be at maximum speed.

Factory setting: values determined at the factory by the X.TUNE function

If the control speed is limited, values can be entered for *Open* and *Close* which are between the minimum values determined by the X.TUNE and 60 s.

Enter the limit of the control speed as follows: ( **Setting on the process level** )


- ▲ / ▼ Select **X.TIME**. The limit of the mechanical stroke range is indicated on the display.
- Select **ENTER**. The input screen for inputting the limit of the control speed is displayed.
- Select **INPUT**.  
The *Open* 1 input screen for inputting values is opened.
- ▲ / ▼ Enter value: Opening time for total stroke (in seconds)  
Adjustment range: 1...60 seconds
  - Increase value
  - Reduce value
- Select **INPUT**.  
The *CLOSE* 1 input screen for inputting values is opened.

→ ▲ / ▼ Enter value: Closing time for total stroke (in seconds)

Adjustment range: 1...60 seconds

+ Increase value

- Reduce value

→  Select **OK** \*. Acknowledge input and return to the display of X.TIME.

✓ You have entered the limit of the control speed.

\* If the submenu is left by pressing the ESC key, the value remains unchanged.



The changed data is saved in the memory (EEPROM) only when there is a switch to the process level, by leaving the main menu (MAIN) using the left selection key **EXIT**.

### Effect of limiting the opening speed when there is a jump in the set-point value

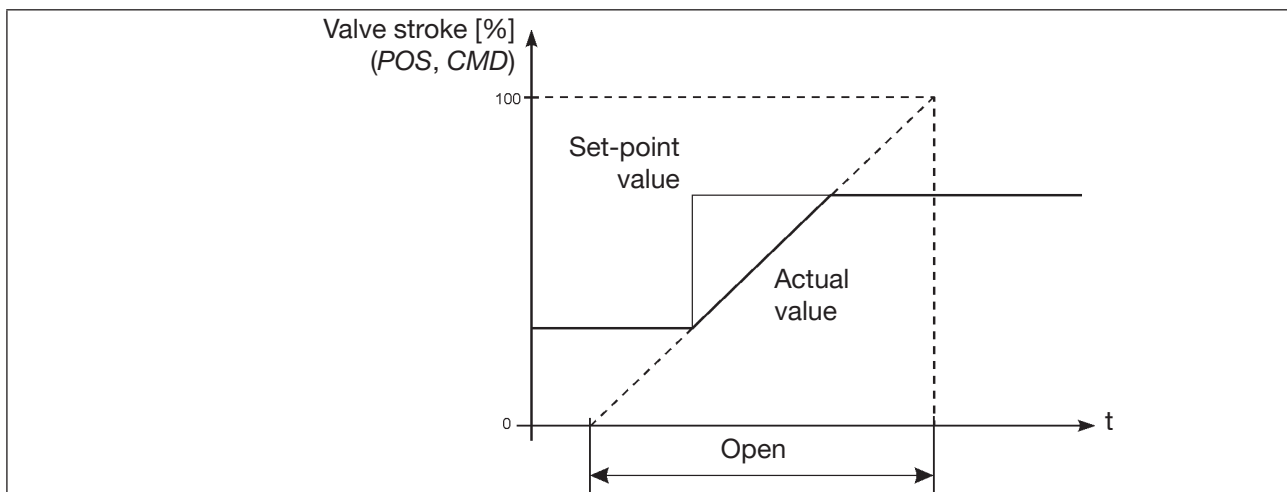


Figure 38: X.TIME graph

### 16.1.10 X.CONTROL – Parameterization of the positioner

This function can be used to re-adjust the parameters of the positioner. The re-adjustment should only be made if it is required for the application.

The parameters for X.CONTROL are automatically set with the exception of DBND (dead band) when specifying the basic settings by running X.TUNE.



If the setting for DBND (dead band depending on the friction behavior of the actuating drive) is also to be automatically determined when X.TUNE is running, X.CONTROL must be activated by incorporating it into the main menu (MAIN).

When X.TUNE is running, all previously re-adjusted values are overwritten (except the X.TUNE function was manually parameterized).

<b>DBND</b>	Insensitivity range (dead band)
<b>KXopn</b>	Amplification factor of the proportional portion (for aerating the valve)
<b>KXcls</b>	Amplification factor of the proportional portion (for bleeding the valve)
<b>KDopn</b>	Amplification factor of the differential portion (for aerating the valve)
<b>KDcls</b>	Amplification factor of the differential portion (for bleeding the valve)
<b>YBfric</b>	Friction correction (for aerating the valve)
<b>YEfric</b>	Friction correction (for bleeding the valve)

Enter the parameterization of the position controller as follows: (Setting on the process level)

- ▲ / ▼ Select **X.CONTROL**. The limit of the mechanical stroke range is indicated on the display.
- Select **ENTER**. The input screen for parameterization of the position controller is displayed.
- Select **INPUT**.  
The input screen *DBND 1%, KXopn, KXcls, KDopn, KDcls, YBfric and YEfric* for inputting values is opened.
- ▲ / ▼ Enter value:
  - Increase value
  - Reduce value
- Select **OK** \*.

✔ You have entered the parameterization of the position controller.  
\* If the submenu is left by pressing the **ESC** key, the value remains unchanged.

**DBND**      Insensitivity range (dead band) of the positioner

Input the dead band as %, with reference to the scaled stroke range;  
i.e.  $X.LIMIT Max - X.LIMIT Min$  (see auxiliary function “[26.2.6. X.LIMIT – Limit of the mechanical stroke range](#)”).

This function causes the controller to respond only from a specific control difference; as a result the solenoid valves in Type 8792/8793 and the pneumatic actuator are protected.

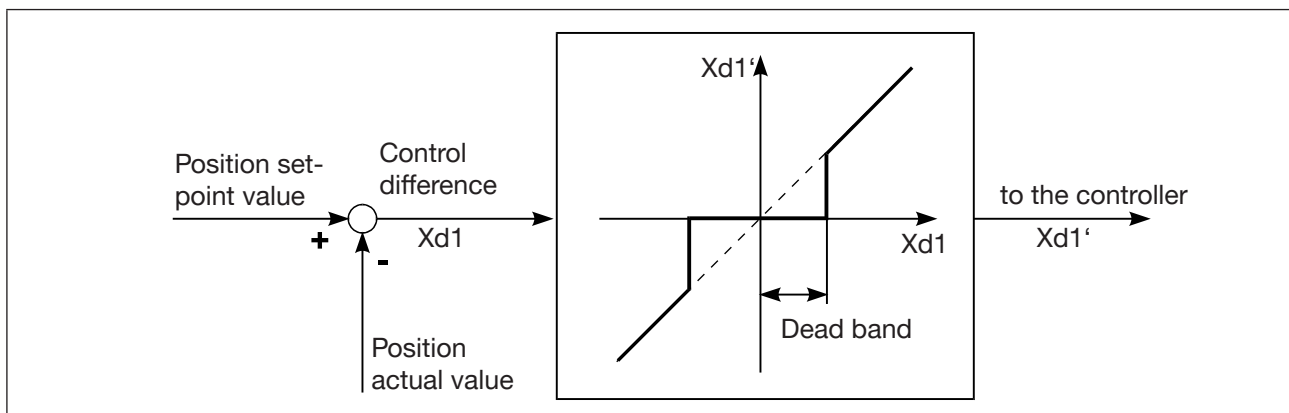


Figure 39: X.CONTROL graph

### 16.1.11 P.CONTROL – Setting up and parameterization of the process controller

Parameterization of the process controller is described in chapter [“25.1. P.CONTROL – Setting up and parameterization of the process controller”](#).










### 16.1.12 SECURITY – Code protection for the settings

Use the *SECURITY* function to prevent Type 8792/8793 or individual functions from being accessed unintentionally.

Factory setting: *Access Code*: 0000

If the code protection is activated, the code (set *Access Code* or master code) must be input whenever operator action is disabled.

Set the code protection as follows:

-  Press **MENU** for 3 s. Switching from process level ⇒ setting level.
  - ▲ / ▼ Select *SECURITY* (To do this, the auxiliary function must be incorporated into the main menu).
  -  Select **ENTER**. The input screen for the access code (*Access Code*) is displayed.
  - ▲ / ▼ Select **<-** decimal place and **+** increase number.  
Enter code.  
For the first setting: *Access Code* 0000 (factory settings)  
For activated code protection: *Access Code* from the user \*
  -  Select **OK**. The submenu of *SECURITY* is opened.
  - ▲ / ▼ Select *CODE*.
  -  Select **INPUT**.  
The input screen for specifying the access code (*Access Code*) is displayed.
  - ▲ / ▼ Select **<-** decimal place and **+** increase number.  
Enter required access code.
  -  Select **OK**. Acknowledgment and return to the *SECURITY* menu.
  - Select ▲ / ▼. Select operator actions to which the code protection is to apply.
  -  Select **SELECT**. Activate code protection by checking the box .
  -  Select **EXIT**. Acknowledgment and simultaneous return to the main menu (MAIN).
  -  Select **EXIT**. Switching from setting level ⇒ process level.
-  You have set the code protection.



The changed data is saved in the memory (EEPROM) only when there is a switch to the process level, by leaving the main menu (MAIN) using the left selection key **EXIT**.



\* If you have forgotten the set code:  
All operator actions can be implemented with the non-changeable master code. This 4-digit master code can be found in the printed brief instructions for Type 8792/8793.

### 16.1.13 SAFEPOS – Inputting the safety position

This function specifies the actuator safety position which is started at defined signals.



#### The set safety position is only started

- if a corresponding signal is applied to the binary input (configuration see *chapter “26.2.13. BINARY.IN – Activation of the binary input”*) or
- if a signal fault occurs (configuration see *chapter “26.2.12.SIG.ERROR – Configuration of signal level fault detection”*).

In the case of the bus version (EtherNet/IP, PROFINET, Modbus TCP et bÜS) the safety position is also started with

- corresponding parameter telegram
- *BUS ERROR* (adjustable)

If the mechanical stroke range is limited with the *X.LIMIT* function, only safety positions within these limits can be started.


This function is run in AUTOMATIC operating state only.



Factory setting: 0%

Enter the safety position as follows: (Setting on the process level)

→ ▲ / ▼ Select **SAFEPOS**. (To do this, the auxiliary function must be incorporated into the main menu).

→  Select **ENTER**. The input screen for parameterization of the position controller is displayed.

→  Select **INPUT**.  
Inputting the safety position adjustment range: 0...100%\*\*

→ ▲ / ▼ Enter value:  
 Increase value  
 Reduce value

→  Select **OK** \*.

✔ You have entered the safety position.

\* If the submenu is left by pressing the **ESC** key, the value remains unchanged.

\*\* If the safety position is 0% or 100%, the actuator is completely deaerated or aerated as soon as the safety position is active in the *SIG-ERROR* or *BINARY-IN* auxiliary functions.



The changed data is saved in the memory (EEPROM) only when there is a switch to the process level, by leaving the main menu (**MAIN**) using the left selection key **EXIT**.

## 16.1.14 SIG.ERROR – Configuration of signal level fault detection

The *SIG.ERROR* function is used to detect a fault on the input signal.

If signal fault detection is activated, the respective fault is indicated on the display.  
(See chapter “35.1. Error Messages on the Display”.)

A fault detection on the input signal is only possible for signal types 4 -20 mA and Pt 100.  
The particular menu branch is hidden for other signal types.

- **4 - 20 mA:** Fault if input signal  $\leq 3.5$  mA ( $\pm 0.5\%$  of final value, hysteresis 0.5% of final value)
- **Pt 100** (can be set for process controller Type 8793 only):  
Fault if input signal 225 °C ( $\pm 0.5\%$  of final value, hysteresis 0.5% of final value)









The signal type is set in the following menus:







1. *INPUT* (for Types 8792 and 8793):  
See chapter “23.1. INPUT - Setting the input signal”.
2. *P.CONTROL* (for Type 8793 only and when process controller activated):  
See chapter “25.2.1. PV-INPUT – Specifying signal type for the process actual value”.

**NOTE:** The fault detection is only possible if the external set-point value default was selected in *SP-INPUT*. See chapter “25.2.3. SP-INPUT – Type of set-point value default (internal or external)”.

Set the signal fault detection for input signal as follows: ( Setting on the process level)

- ▲ / ▼ Select *SIG.ERROR*. (To do this, the auxiliary function must be incorporated into the main menu).
-  Select **ENTER**. The input screen for setting the signal fault detection for input signal is displayed.
- ▲ / ▼ Select *SP/CMD Input*. *SP* = process set-point value, *CMD* = set-point position
-  Select **ENTER**.
- ▲ / ▼ Select *Error off* (deactivate signal fault detection).  
Select *Error on* (activate signal fault detection).
-  Select **SELEC**. The selection is marked by a filled circle ●.
- ▲ / ▼ Select *SAFEPOS* (Deactivating/activating approach of the safety position\*).
- ▲ / ▼ Select *SafePos off*.  
Select *SafePos on\*\**.
-  Select **SELEC**. The selection is marked by a filled circle ●.
-  Select **EXIT** and return to the *SP/CMD* input menu.
-  Select **EXIT** and return to the *SIG.ERROR* menu.

**Only for type 8793 (process control):**

- ▲ / ▼ Select **SIG.ERROR**. (To do this, the auxiliary function must be incorporated into the main menu).
-  Select **ENTER**. The input screen for setting the signal fault detection for input signal is displayed.
- ▲ / ▼ Select **PV-Input**. *PV = process actual value*
-  Select **ENTER**.
- ▲ / ▼ Select **Error off** (deactivate signal fault detection).  
Select **Error on** (activate signal fault detection).
-  Select **SELEC**. The selection is marked by a filled circle ●.
- ▲ / ▼ Select **SAFEPOS** (Deactivating/activating approach of the safety position\* ).
- ▲ / ▼ Select **SafePos off**.  
Select **SafePos on\*\***.
-  Select **SELEC**. The selection is marked by a filled circle ●.
-  Select **EXIT** and return to the SP/CMD input menu.
-  Select **EXIT** and return to the SIG.ERROR menu.
- ✔ You have set the signal fault detection for input signal.

\* Approaching the safety position can be set only when signal fault detection (Error on) has been activated. When signal fault detection (Error off) has been deactivated, the message “not available” is indicated.

\*\* For behavior of the actuator during a signal fault detection see the following description.

### 16.1.14.1. Behavior of the actuator when safety position deactivated or activated

Selection *SafePos off* ● – The actuator remains in the position which corresponds to the set-point value last transferred (default setting).

Selection *SafePos on* ● – Approaching the safety position activated:

In the event of a signal fault detection, the behavior of the actuator depends on the activation of **SAFEPOS** auxiliary function. See chapter “[26.2.11. SAFEPOS – Inputting the safety position](#)”.

- **SAFEPOS** activated: In the event of a signal fault detection the actuator moves to the position which is specified in the **SAFEPOS** auxiliary function.
- **SAFEPOS** not activated: The actuator moves to the safety end position which it would assume if the electrical and pneumatic auxiliary power failed.  
See chapter “[10.9. Safety end positions after failure of the electrical or pneumatic auxiliary power](#)”.



The activation for approaching the safety position (selection *SafePos on*) is possible only when signal fault detection has been activated (**ERROR on**).

### 16.1.15 *BINARY.IN* – Activation of the binary input








The binary input is configured in this menu. The following functions can be assigned to it:

- SafePos    Approaching *SafePos*
- Manu/Auto    Switching over the operating state (MANUAL / AUTOMATIC)
- X.TUNE    Starting the *X.TUNE* function

Only for Type 8793 and when process controller activated:

- X.CO/P.CO    Switching between position and process controller

Activate the digital inputs as follows: (**Setting on the process level**)

- ▲ / ▼ Select *BINARY.IN*. (To do this, the auxiliary function must be incorporated into the main menu).
-  Select **ENTER**. The input screen for activating the digital inputs is displayed.
- ▲ / ▼ Select different *BIN.IN*.  
Select *SafePos*. Approaching *SafePos*,  
select *Manu/Auto*. Switch over operating state,  
select *X.Tune*. Start *X.TUNE*, select  
*X.CO / P.CO* . Switching between position controller and process controller or  
select *BIN.IN type* and activate *normally open or normally closed* .
-  Select **SELECT**. The selection is marked by a filled circle .
-  Select **EXIT**.
-  Select **EXIT**. Switching from setting level  $\Rightarrow$  process level.
-  You have activated the digital inputs.

#### **SafePos – Approaching a safety position:**

The behavior of the actuator depends on the activation of the *SAFEPOS* auxiliary function. See chapter [“26.2.11. SAFEPOS – Inputting the safety position”](#).

*SAFEPOS* activated:     The actuator moves to the safety position which is specified in the *SAFEPOS* auxiliary function.

*SAFEPOS* deactivated: The actuator moves to the safety end position which it would assume if the electrical and pneumatic auxiliary power failed.  
See chapter [“10.9. Safety end positions after failure of the electrical or pneumatic auxiliary power”](#).

Binary input = 1     → Actuator moves to the set safety position.

#### **Manu/Auto – Switching between the MANUAL and AUTOMATIC operating states:**

Binary input = 0     → AUTOMATIC operating state AUTO

Binary input = 1     → MANUAL operating state MANU





If the *Manu/Auto* function was selected in the *BINARY.IN* menu, it is no longer possible to change the operating state on the process level using the **MANU** and **AUTO** keys.

**X.TUNE** – Starting the *X.TUNE* function:

Binary input = 1 → Start *X.TUNE*

**X.CO/P.CO** – Switching between position controller and process controller:

This menu option stands only for Type 8793 and is available when process controller (*P.CONTROL*) has been activated.

Binary input = 0 → Position controller (*X.CO*)

Binary input = 1 → Process controller (*P.CO*)

### 16.1.16 OUTPUT – Configuration of the outputs (option)



The *OUTPUT* menu option is only indicated in the selection menu of *ADD.FUNCTION* if Type 8792/8793 has outputs (option).

Type 8792/8793, which has the outputs option, is available in the following variants:

- one analog output
- one analog output and two binary outputs
- two binary outputs




According to the variant of Type 8792/8793, only the possible adjustable outputs (*ANALOG*, *ANALOG + BIN 1 + BIN 2* or *BIN 1 + BIN 2*) are indicated in the *OUTPUT* menu option.

Configure the outputs as follows: ( Setting on the process level)


→ ▲ / ▼ Select *OUTPUT*. (To do this, the auxiliary function must be incorporated into the main menu).

→  Select **ENTER**. The input screen for configuring the outputs is displayed.

→ ▲ / ▼ Select *OUT ANALOG*.


→  Select **ENTER** and configure the analog output.

→ ▲ / ▼ Select *OUT BIN1*.

→  Select **ENTER** and configure the digital output 1.

→ ▲ / ▼ Select *OUT BIN2*.

→  Select **ENTER** and configure the digital output 2.

→  Select **EXIT**. Switching from setting level ⇒ process level.










✔ You have configured the outputs.

### 16.1.16.1. OUT ANALOG - Configuration of the analog output

**Type 8792:** The feedback of the current position (*POS*) or of the set-point value (*CMD*) can be transmitted to the control center via the analog output.

**Type 8793:** The feedback of the current position (*POS*) or of the set-point value (*CMD*), of the process actual value (*PV*) or of the process set-point value (*SP*) can be transmitted to the control center via the analog output.

**Configure the analog output as follows: (Setting on the process level)**

- ▲ / ▼ Select *OUT ANALOG*. (To do this, the auxiliary function must be incorporated into the main menu).
-  Select **ENTER**. The input screen for configuring the analog output is displayed.
- ▲ / ▼ Select *POS*. Output of the actual position.
-  Select **SELEC**. The selection is marked by a filled circle ●.
- ▲ / ▼ Select *CMD*. Output of the set-point position.
-  Select **SELEC**. The selection is marked by a filled circle ●.
- ▲ / ▼ Select *PV*. Output of the process actual value. (**Only for Type 8793**, process control)
-  Select **SELEC**. The selection is marked by a filled circle ●.
- ▲ / ▼ Select *SP*. (**Only for Type 8793** (process control)
-  Select **SELEC**. Output of the process set-point value.
- ▲ / ▼ Select *OUT.type*. Selection of the standard signal.
-  Select **ENTER** and configure the standard signal.
- ▲ / ▼ Select standard signal.
-  Select **SELECT**. The selection is marked by a filled circle ●.
-  Select **EXIT** and return to the *OUT.type* menu.
-  Select **EXIT** and return to the *OUT ANALOG* menu.
- ✔ You have configured the analog output.

### 16.1.16.2. OUT BIN1 / OUT BIN2 - Configuring the binary outputs

The following description is valid for both binary outputs *OUT BIN 1* and *OUT BIN 2*, as the operation in the menu is identical.

The binary outputs 1 and 2 can be used for one of the following outputs:

- POS.Dev Exceeding the permitted control deviation
- POS.Lim-1/2 Current position with respect to a specified limit position (> or <)
- Safepos Actuator in safety position
- ERR.SP/CMD Sensor break (SP = process set-point value / CMD = set-point value position)
- ERR.PV Sensor break (process actual value). **Available for Type 8793 only.**
- Remote Operating state (AUTOMATIC / MANUAL)
- Tune.Status Status *X.TUNE* (process optimization)
- DIAG.State-1/2 Diagnostic output (option)

Overview of possible outputs and associated switching signals:

Menu option	Switching signal	Description
<span style="border: 1px solid black; padding: 2px;">POS.Dev</span>	0	Control deviation is within the set limit.
	1	Control deviation is outside the set limit.
<span style="border: 1px solid black; padding: 2px;">POS.Lim-1/2</span>	0	Actual position is above the limit position.
	1	Actual position is below the limit position.
<span style="border: 1px solid black; padding: 2px;">Safepos</span>	0	Actuator is not in the safety position.
	1	Actuator is in the safety position.
<span style="border: 1px solid black; padding: 2px;">ERR.SP/CMD</span>	0	No sensor break available.
<span style="border: 1px solid black; padding: 2px;">ERR.PV</span>	1	Sensor break available.
<span style="border: 1px solid black; padding: 2px;">Remote</span>	0	Appliance is the AUTOMATIC operating state.
	1	Appliance is the MANUAL operating state.
<span style="border: 1px solid black; padding: 2px;">Tune.Status</span>	0	The <i>X.TUNE</i> function is currently not running.
	1	The <i>X.TUNE</i> function is currently running.
	0/1 alternating (10 s)	The <i>X.TUNE</i> function was stopped during execution by a fault.
<span style="border: 1px solid black; padding: 2px;">DIAG.State-1/2</span>	0	No diagnostic message available for the selected status signals.
	1	Diagnostic message available for the selected status signals.




Table 34: OUT BIN 1/2; possible outputs and associated switching signals

Switching signal	Switching statuses	
	normally open	normally closed
0	0 V	24 V
1	24 V	0 V

Table 35: OUT BIN 1/2; switching statuses

### 16.1.16.3. Setting of the submenu options of *OUT BIN 1* and *OUT BIN 2*





Open the submenus as follows:

-  Press **MENU** for 3 s. Switching from process level ⇒ setting level.
- ▲ / ▼ Select *OUTPUT* (to do this, the auxiliary function must be incorporated into the main menu).
-  Select **ENTER**. The outputs are displayed.
- ▲ / ▼ Select *OUT BIN1/2*
-  Select **ENTER**. Submenu options of *OUT BIN 1/2* are displayed.
- ✔ You have opened the submenus.





- *POS.Dev* - Alarm output for excessively large control deviation of the position controller
- *POS.Lim-1/2* - Output of the current position with respect to a specified limit position

Set the suboptions *OUT BIN 1* and *OUT BIN 2*:

*POS.Dev* - Alarm output for excessively large control deviation of the position controller:

- ▲ / ▼ Select *POS.Dev*
-  Select **SELEC**. The input screen for the limit value (*Deviation:*) is opened.
- ▲ / ▼  Increase value  
 Reduce value  
 Enter limit value for permitted control deviation.  
 Adjustment range: 1...50% (must not be less than the dead band).
-  Select **OK**. Acknowledgment and simultaneous return to the *OUT BIN 1/2* menu.  
 Then set the required switching status in the *OUT.type* submenu.


*POS.Lim-1/2* - Output of the current position with respect to a specified limit position:

- ▲ / ▼ Select *POS.Lim-1/2*
-  Select **SELEC**. The input screen for the limit position (*Limit:*) is opened.
- ▲ / ▼  Increase value  
 Reduce value  
 Enter limit position.  
 Adjustment range: 0...100%.
-  Select **OK**. Acknowledgment and simultaneous return to the *OUT BIN 1/2* menu.  
 Then set the required switching status in the *OUT.type* submenu.
- ✔ You have set the submenus.

- **Safepos** - Outputting the message: Actuator in safety position
- **ERR.SP/CMD** - Outputting the message: Sensor break for process set-point value/set-point position  
Only available if the function in the *SIG.ERR* menu has been activated (*SIG.ERR* → *SP/CMD input* → *Error on*).  
See chapter “[26.2.12. SIG.ERROR – Configuration of signal level fault detection](#)”.
- **ERR.PV** - Outputting the message: Sensor break for process actual value (for Type 8793 only)  
Only available if the function in the *SIG.ERR* menu has been activated (*SIG.ERR* → *PV Input* → *Error on*).  
See chapter “[26.2.12. SIG.ERROR – Configuration of signal level fault detection](#)”.
- **Remote** - Output AUTOMATIC / MANUAL operating state
- **Tune.Status** - Output TUNE (process optimization)

Specify the output as follows:

→ ▲ / ▼ Select *suboptions*. (*Safepos*, *ERR.SP/CMD*, *ERR.PV*, *Remote* or *Tune.Status*).

→  Select **SELEC**. Acknowledge submenu option as output function for the digital output. The selection is marked by a filled circle ●.  
Then set the required switching status in the *OUT.type* submenu.

✔ You have specified the output.


- **DIAG.State-1/2** - Diagnostic output (option)

Outputting the message: Diagnostic message from selected status signal


For description see chapter “[26.2.22. DIAGNOSE – Menu for monitoring valves \(option\)](#)”.

Enter the *OUT.type* as follows:


→ ▲ / ▼ Select *DIAG.State-1/2*.

→  Select **SELEC**. The status signals, which can be activated for outputting the message, are displayed.

→ ▲ / ▼ Select *status signal*. Select the status signal which is to be assigned to the diagnostic output.

→  Select **SELEC**. Activate the selection by checking the box  or deactivate it by unchecking the box .

→ If required, activate further status signals for the diagnostic output by pressing the ▲ / ▼ and **SELEC** keys.







→  Select **EXIT**. Acknowledgment and simultaneous return to the *OUT BIN 1/2* menu.  
Then set the required switching status in the *OUT.type* submenu.

✔ You have entered *OUT.type*.

• **OUT.type - Setting the switching status**


In addition to selecting the output, the switching status required for the binary output must be entered. See following “Table 64”.

Enter the OUT.type as follows:

- ▲ / ▼ Select *OUT.type*.
-  Select **SELEC**. The switching statuses *normally open* and *normally closed* are displayed.
- ▲ / ▼ Select switching status.
-  Select **SELEC**. The selection is marked by a filled circle ●.
-  Select **EXIT**. Acknowledgment and simultaneous return to the *OUT BIN 1/2* menu.
-  Select **EXIT**. Acknowledgment and simultaneous return to the *OUTPUT* menu.
-  Select **EXIT**. Acknowledgment and simultaneous return to the main menu (MAIN).
-  Select **EXIT**. Switching from setting level ⇒ process level.
- ✔ You have entered *OUT.type*.

Switching signal	Switching statuses	
	normally open	normally closed
0	0 V	24 V
1	24 V	0 V

Table 36: *OUT BIN 1/2; switching statuses*

 The changed data is saved in the memory (EEPROM) only when there is a switch to the process level, by leaving the main menu (MAIN) using the left selection key **EXIT**.

### 16.1.17 CAL.USER – Calibration of actual value and set-point value

The following values can be manually calibrated with this function:

- Position actual value  (0 - 100%)
- Set-point position  (4 - 20 mA, 0 - 20 mA, 0 - 5 V, 0 - 10 V)  
For the calibration process the signal type is displayed which was specified for the input signal.  
See chapter [“23.1. INPUT - Setting the input signal”](#).

#### Type 8793:

The following values can be calibrated only for Type 8793 and activated process controller (*P.CONTROL*).

- Process set-point value  (4 - 20 mA, 0 - 20 mA, 0 - 5 V, 0 - 10 V)  
For the calibration process the signal type is displayed which was specified for the input signal.  
See chapter [“23.1. INPUT - Setting the input signal”](#).



The calibration of the process set-point value is only possible if the external set-point value default was selected when setting up the process controller.  
See chapter [“25.2.3. SP-INPUT – Type of set-point value default \(internal or external\)”](#).  
Setting: *P.CONTROL* → *SETUP* → *SP-INPUT* → *external*




- Process actual value  (4 - 20 mA or °C)  
For the calibration process the signal type is displayed which was specified for the process actual value when setting up the process controller.  
See chapter [“25.2.1. PV-INPUT – Specifying signal type for the process actual value”](#).








The frequency signal type (flow rate) cannot be calibrated.  
If the frequency was set when setting up the process controller (*P.CONTROL* → *SETUP* → *PV-INPUT* → *Frequency*), the *calibr. PV* menu option is hidden.





#### 16.1.17.1. Calibration of the position actual value and the set-point position

Calibrate *CAL.USER* as follows:







-  Press **MENU** for 3 s. Switching from process level ⇒ setting level.
-  Select *CAL.USER*. (To do this, the auxiliary function must be incorporated into the main menu).
-  Select **ENTER**. The submenu options are displayed.

*calibr. POS* - Calibration of the position actual value (0...100%):

-  Select *calibr.POS*.
-  Select **ENTER**. The menu options for the minimum and the maximum position actual values are displayed.
-  Select *POS. pMin*.
-  Select **INPUT**. The input screen for the lower value (*POS.lower*) is opened.
-  Select **OPN** open more  
**CLS** close more. Approach minimum position of the valve.



-  Select **OK**. Transfer and simultaneous return to the *calibr.POS* menu.
- ▲ / ▼ Select *POS. pMax*.
-  Select **INPUT**. The input screen for the upper value (*POS.upper*) is opened.
- ▲ / ▼ Select **OPN** open more  
**CLS** close more. Approach maximum position of the valve.
-  Select **OK**. Transfer and simultaneous return to the *calibr.POS* menu.
-  Select **EXIT**. Acknowledgment and simultaneous return to the *CAL.USER* menu.

*calibr. INP* - Calibration of the set-point position (4...20 mA, 0...20 mA, 0...5 V, 0...10 V):


- ▲ / ▼ Select *calibr.INP*.
-  Select **ENTER**. The menu options for the minimum and maximum value of the input signal are displayed.
- ▲ / ▼ Select *INP 0 mA (4mA/0V)*. The minimum value for the input signal is displayed.
- Apply the minimum value to the input.
-  Select **OK**. Transfer and simultaneous return to the *calibr.INP* menu.
- ▲ / ▼ Select *INP 20 mA (5V/10V)*. The maximum value for the input signal is displayed.
- Apply the maximum value to the input.
-  Select **OK**. Transfer and simultaneous return to the *calibr.INP* menu.
-  Select **EXIT**. Acknowledgment and simultaneous return to the *CAL.USER* menu.
-  Select **EXIT**. Acknowledgment and simultaneous return to the main menu (MAIN).
-  Select **EXIT**. Switching from setting level ⇒ process level.
- ✓ You have calibrated *CAL.USER*.

### 16.1.17.2. Calibration of the process set-point value and the process actual value




Calibrate *CAL.USER* as follows:

-  Press **MENU** for 3 s. Switching from process level ⇒ setting level.
- ▲ / ▼ Select *CAL.USER*. (To do this, the auxiliary function must be incorporated into the main menu).
-  Select **ENTER**. The submenu options are displayed.





*calibr. SP* - Calibration of the process set-point value:

- ▲ / ▼ Select *calibr. SP*.
-  Select **ENTER**. The menu options for the minimum and the maximum process set-point value are displayed.
- ▲ / ▼ Select *SP 0 mA (4mA/0V)*. The minimum value for the input signal is displayed.
- Apply the minimum value to the input.







-  Select **OK**. Transfer and simultaneous return to the *calibr.SP* menu.
- ▲ / ▼ Select *SP 20 mA (5V/10V)*. The maximum value for the input signal is displayed.
- Apply the maximum value to the input.
-  Select **OK**. Transfer and simultaneous return to the *calibr.SP* menu.
-  Select **EXIT**. Acknowledgment and simultaneous return to the *CAL.USER* menu.

*calibr. PV* - Calibration of the process actual value for input signal 4...20 mA:






- ▲ / ▼ Select *calibr. PV*.
-  Select **ENTER**. The menu options for the minimum and the maximum process actual value are displayed.
- ▲ / ▼ Select *PV 4 mA*. The minimum value for the input signal is displayed.
- Apply the minimum value to the input.
-  Select **OK**. Transfer and simultaneous return to the *calibr.PV* menu.
- ▲ / ▼ Select *PV 20mA*. The maximum value for the input signal is displayed.
- Apply the maximum value to the input.
-  Select **OK**. Transfer and simultaneous return to the *calibr.PV* menu.
-  Select **EXIT**. Acknowledgment and simultaneous return to the *CAL.USER* menu.

*calibr. PV* - Calibration of the process actual value for input signal Pt 100:

- ▲ / ▼ Select *calibr.PV*.
-  Select **ENTER**. The input screen for calibration of the temperature is opened.
- ▲ / ▼ Select **<-** decimal place and **+** increase number.  
Enter the current temperature.
-  Select **OK**. Transfer and simultaneous return to the *CAL.USER* menu.
-  Select **EXIT**. Acknowledgment and simultaneous return to the main menu (MAIN).
-  Select **EXIT**. Switching from setting level ⇒ process level.
- ✔ You have calibrated *CAL.USER*.

### 16.1.17.3. Resetting the settings under *CAL.USER* to the factory settings

Reset the settings as follows:

-  Press **MENU** for 3 s. Switching from process level ⇒ setting level.
  - ▲ / ▼ Select *CAL.USER*. (To do this, the auxiliary function must be incorporated into the main menu).
  -  Select **ENTER**. The submenu options are displayed.
  - ▲ / ▼ Select *copy FACT->USER*.
  -  Select **RUN**. Hold down as long as countdown (5 ...) is running. The settings of *CAL.USER* are reset to the factory settings.
  -  Select **EXIT**. Acknowledgment and simultaneous return to the main menu (MAIN).
  -  Select **EXIT**. Switching from setting level ⇒ process level.
- ✔ You have reset the settings.






The factory calibration is re-activated by deactivating *CAL.USER*, by removing the auxiliary function from the main menu (MAIN).

### 16.1.18 *SET.FACTORY* – Reset to factory settings

This function allows all settings implemented by the user to be reset to the delivery status.

All EEPROM parameters with the exception of the calibration values are reset to default values. Then a hardware reset is implemented.

Reset the settings to factory setting as follows:

-  Press **MENU** for 3 s. Switching from process level ⇒ setting level.
  - ▲ / ▼ Select *SET.FACTORY*. (To do this, the auxiliary function must be incorporated into the main menu).
  -  Press **RUN** for 3 s (until progress bar is closed) “factory reset” is shown. Reset is implemented.
  -  Select **EXIT**. Switching from setting level ⇒ process level.
- ✔ You have reset the settings.




To adjust Type 8792/8793 to the operating parameters, re-implement self-parameterization of the positioner (*X.TUNE*).

### 16.1.19 SERVICE.BUES – Setting the service interface

Set the service interface as follows:

→  Press **MENU** for 3 s. Switching from process level ⇒ setting level.

→ ▲ / ▼ Select *SERVICE.BUES*.

→  Select **ENTER**. The possible BUES are displayed.

Select baud rate:

→ ▲ / ▼ Select *baud rate*.

→  Select **ENTER**. The possible *baud rates* are displayed.


▲ / ▼ Select *baud rate* 1000 kbit/s

500 kbit/s

250 kbit/s

125 kbit/s

50 kbit/s.

→  Select **OK**. Return to BUS.COMM.

Setting device address:


→ ▲ / ▼ Select *address*.

→  Select **INPUT**. The possible *addresses* are displayed.

→ ▲ / ▼ Select **+** Increase value or **-** reduce value.

Enter a device address (*value between 0 and 127*).

→  Select **SELECT**. The selected address is now marked by a filled circle ●.

→  Select **EXIT**. Switching from setting level ⇒ process level.
















✔ You have set the service interface.

### 16.1.20 EXTRAS – Setting the display



This function can be used to individually set the display.


- In *DISP.ITEMS* the display of the process level can be individually set.  
To do this, further menu options can be activated for the display of the process level. *POS* and *CMD* are activated in the as-delivered state.
- In *START-UP.ITEM* one of the activated menu options is specified as a start display after a restart.
- The type of display is selected via *DISP.MODE*.  
*normal* = black font on light background.  
*inverse* = white font on dark background.
- *DISP.LIGHT* is used to define the background lighting of the display.  
*on* = Background lighting on.  
*off* = Background lighting off.  
*user active* = Background lighting switches off after 10 seconds with no user interaction. If a key is pressed again, the background lighting goes on again.

Activate the menu displays for displaying the process level as follows:

-  Press **MENU** for 3 s. Switching from process level ⇒ setting level.
  -  Select *ADD.FUNCTION*.
  -  Select **ENTER**. The possible auxiliary functions are displayed.
  -  Select *EXTRAS*.
  -  Select **ENTER**.  
Activate the *EXTRAS* auxiliary function by checking the box  and transfer into the main menu.
  -  Select **EXIT**. Return to the main menu (MAIN).
  -  Select *EXTRAS*.
  -  Select **ENTER**. The submenus of *EXTRAS* are displayed.
  -  Select *DIP.ITEMS*.
  -  Select **ENTER**.  
The possible menu options are displayed.  
*POS, CMD, CMDIPOS, CMD/POS(t), CLOCK, INPUT, TEMP, X.TUNE.*  
Additionally for process controller Type 8793:  
*PV, SP, SPIPV, SP/PV(t), P.TUNE, P.LIN.*
  -  Select required menu options.
  -  Select **SELEC**. Activate the selection by checking the box  or deactivate it by unchecking the box .
  -  Select **EXIT**. Return to the *EXTRAS* menu.
  -  Select **EXIT**. Return to the main menu (MAIN).
  -  Select **EXIT**. Switching from setting level ⇒ process level.
- You have activated the menu display.

The activated menu options are now displayed on the process level display.

Use the arrow keys   to switch between the displays.

 Each menu option which can be selected can also be deactivated so that it is not indicated on the process level display.  
However, there must be at least one menu option available which can be indicated on the display.  
If nothing was selected, the *POS* menu option is automatically activated.

**START-UP.ITEM** - Specifying menu option for the start display:










**EXTRAS** → **START-UP.ITEM**   Select menu option and specify with **SELEC**.

The menu option for the start display is marked by the filled circle .

The detailed procedure can be found in the extensive menu description for *DISP.ITEMS*. The *START-UP.ITEM* and *DISP.ITEMS* menus are set in the same way.

**DISP.MODE** - Select type of display  
(black font on light background or white font on dark background):

Select the type of display as follows:

-  Press **MENU** for 3 s. Switching from process level ⇒ setting level.
- ▲ / ▼ Select **ADD.FUNCTION**.
-  Select **ENTER**. The possible auxiliary functions are displayed.
- ▲ / ▼ Select **EXTRAS**.
-  Select **ENTER**.  
Activate the **EXTRAS** auxiliary function by checking the box  and transfer into the main menu.
-  Select **EXIT**. Return to the main menu (MAIN).
- ▲ / ▼ Select **DISP.MODE**.
-  Select **ENTER**.  
The possible menu options for the type of display are shown.  
*normal* = black font on light background  
*inverse* = white font on dark background
- ▲ / ▼ Select the type of display.
-  Select **SELEC**.  
The selection is marked by a filled circle ●.
-  Select **EXIT**. Return to the **EXTRAS** menu.
-  Select **EXIT**. Return to the main menu (MAIN).
-  Select **EXIT**. Switching from setting level ⇒ process level.
- ✔ You have set the type of display.

**DISP.LIGHT** - Define background lighting for display:

**EXTRAS** → **DISP.LIGHT** ▲ / ▼ Background lighting and specify with **SELEC**.

The menu option for the background lighting is marked by the filled circle ●.

- on* = Background lighting on.
- off* = Background lighting off.
- user active* = Background lighting switches off after 10 seconds with no user interaction. If a key is pressed again, the background lighting goes on again.

The detailed procedure can be found in the extensive menu description for **DISP.MODE**. The **DISP.LIGHT** and **DISP.MODE** menus are set in the same way.

### 16.1.21 POS.SENSOR

#### Setting interface remote position sensor

The interface for the connection of an external position sensor can be selected in this menu.

The following connection options are possible:

Interface	Position sensor	Setting in the menu (ADD.FUNCTION)
digital (serial)	Remote sensor Type 8798.	POS.SENSOR → DIGITAL
analog (4 - 20 mA) *	any high-resolution position sensor.	POS.SENSOR → ANALOG

Table 37: Connection options Type 8793 with external position sensor



\* If the external position sensor is connected to the process controller Type 8793 via the analog interface, it can be operated only as a positioner (position controller).

The P.CONTROL auxiliary function is automatically removed.

#### Setting the interface remote position sensor:

- Press **MENU** for 3 s. Switching from process level ⇒ setting level.
- ▲ / ▼ Select **POS.SENSOR**. (To do this, the auxiliary function must be incorporated into the main menu).
- Select **ENTER**. The submenu options are displayed.
- ▲ / ▼ Select **DIGITAL**.
- Select **ENTER**.

The position signal of the external position sensor is digitally transmitted

Digital interface (menu option **POS.SENSOR → DIGITAL**):

Type 8792/8793 is connected to the path sensor Type 8798 via a digital interface (see chapter [“Terminal assignment for external position sensor \(for remote variant only\)”](#) on page 137).

or

- ▲ / ▼ Select **ANALOG**.
- Select **ENTER**.

The position signal of the external position sensor is transmitted analog

Analog interface (menu option **POS.SENSOR → ANALOG**):

Type 8793 is connected with any external position sensor with a 4...20 mA output signal via an interface 4...20 mA. To do this, the external position sensor is connected to the process actual value input (see chapter [“Terminal assignments of the process actual value input”](#) on page 137).

If the external position sensor requires an additional power supply of 24 V DC, it can be supplied via the positioner.

- Select **EXIT**. Acknowledgment and simultaneous return to the main menu (MAIN).
- Select **EXIT**. Switching from setting level ⇒ process level.










✔ You have set the remote position sensor interface.

### Tangent correction










When attaching the positioner according to NAMUR to a linear actuator, the linear position of the actuator is converted into a rotated position measured by the positioner.

This results in a non-linear correlation ( $POS \sim \tan(\alpha)$ ) that is corrected by the tangent correction.

#### Setting the tangent correction:

-  Press **MENU** for 3 s. Switching from process level  $\Rightarrow$  setting level.
-  Select *POS.SENSOR*. (To do this, the auxiliary function must be incorporated into the main menu).
-  Select **ENTER**. The submenu options are displayed.
-  Select *TAN.CORRECTION*.
-  Select **ENTER**.
-  Select *tan.corr on*.
-  Select **ENTER**.
-  Select **EXIT**.
-  Select **EXIT**. Switching from setting level  $\Rightarrow$  process level.
- ✔ You have set the tangent correction.

#### Set the angle used by the position sensor as follows:

-  Press **MENU** for 3 s. Switching from process level  $\Rightarrow$  setting level.
-  Select *POS.SENSOR*. (To do this, the auxiliary function must be incorporated into the main menu).
-  Select **ENTER**. The submenu options are displayed.
-  Select *ALPHA*.
-  Select **ENTER**.
-  Select angle.  
Example: angle used  $60^\circ \Rightarrow \alpha = +/- 30^\circ$
-  Select **ENTER**.
-  Select **EXIT**.
-  Select **EXIT**. Switching from setting level  $\Rightarrow$  process level.
- ✔ You have set the angle used by the position sensor.

### 16.1.22 SERVICE

This function is of no importance to the operator of Type 8792/8793. It is for internal use only.

### 16.1.23 SIMULATION – Menu for simulation of set-point value, process and process valve

This function can be used to simulate set-point value, process and process valve independently of each other.

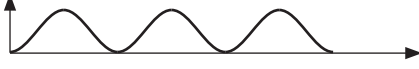




**Note!** Restarting the device deactivates the simulation.  
The settings of *SIGNAL.form*, *x.SIM* and *p.SIM* are reset to the factory setting.

#### 16.1.23.1. *SIGNAL.sim* – Simulation of the set-point value

The settings to simulate the set-point value are made in the *SIGNAL.sim* menu.

**Activation of the simulation:** In the *SIGNAL.form* submenu by selecting one of the following waveforms

- Sine** Sine wave 
- Square** Square wave 
- Triangle** Triangle wave 
- Mixed** Single cycle of an alternating signal sequence.  
Then the selection is set to *External* (set-point value simulation inactive).

The following parameters can be set for the selected waveform.

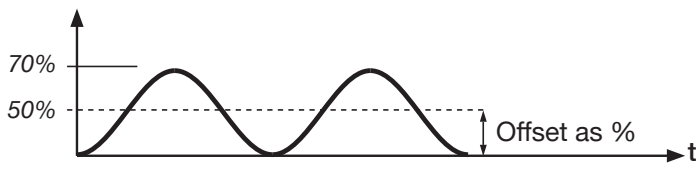
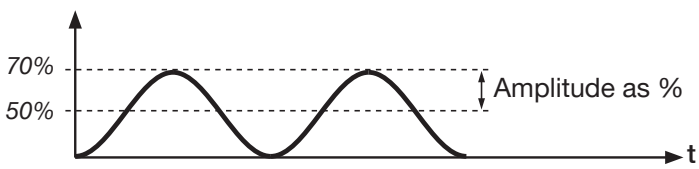
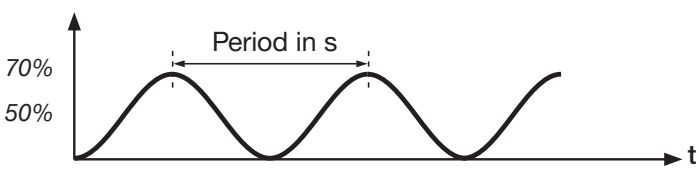
Menu option	Parameter setting	Schematic representation with sine wave
<input type="checkbox"/> <b>Offset</b>	(Zero offset as %)	
<input type="checkbox"/> <b>Amplitude</b>	(Amplitude as %)	
<input type="checkbox"/> <b>Period</b>	(Cycle duration in s)	







Table 38: *SIGNAL.sim*; parameter settings for set-point value simulation



**Deactivation of the simulation:** In the *SIGNAL.form* submenu



Selection  = set-point value simulation inactive  
(corresponds to the factory setting in the as-delivered state)

**Activate and parameterize the set-point value simulation as follows:**














-  Press **MENU** for 3 s. Switching from process level  $\Rightarrow$  setting level.
-  Select *SIMULATION*. (To do this, the auxiliary function must be incorporated into the main menu).
-  Select **ENTER**. The submenu for setting the simulation is displayed.
-  Select *SIGNAL.sim*.
-  Select **ENTER**.  
The submenu for activating and parameterizing the set-point value simulation is displayed.
-  Select *required menu option*

Selection  = simulation inactive.

Selection  /  /  /  = specify the waveform as well as activation of the simulation.

-  Select **SELEC**. The selection is marked by a filled circle .
-  Select **EXIT**. Return to the *SIGNAL.sim* menu.

Setting the parameters for simulation of the set-point value:


-  Select *offset* (zero offset as%).
-  Select **INPUT**. The input screen for specifying the offset is opened.
-   Increase value  
 Select decimal place and enter value.
-  Select **OK**. Transfer and simultaneous return to the *SIGNAL.sim* menu.
-  Select *amplitude* (amplitude as%).
-  Select **INPUT**. The input screen for specifying the amplitude is opened.
-   Increase value  
 Select decimal place and enter value.
-  Select **OK**. Transfer and simultaneous return to the *SIGNAL.sim* menu.
-  Select *period* (period duration in seconds).
-  Select **INPUT**. The input screen for specifying the cycle duration is opened.
-   Increase value  
 Select decimal place and enter value.
-  Select **OK**. Transfer and simultaneous return to the *SIGNAL.sim* menu.
-  Select **EXIT**. Return to the *SIMULATION* menu.

For simulation of process and process valve:

→ ▲ / ▼ Select *CONTROL.sim*.

For description see chapter “16.1.23.2. *CONTROL.sim* – Simulation of the process and process valve”.

Leaving the *SIMULATION* menu:

→  Select **EXIT**. Return to the main menu (MAIN).

→  Select **EXIT**. Switching from setting level ⇒ process level.

✔ You have activated and parameterized the set-point value simulation.

### 16.1.23.2. *CONTROL.sim* – Simulation of the process and process valve

The settings to simulate the process and the process valve are made in the *CONTROL.sim* menu.

#### Settings

Type of simulation:  Simulation of the process valve.

Simulation of the process.

Parameterization of the process:  Specify amplification factor.

Specify time constant in seconds.

Example of a simulated process:

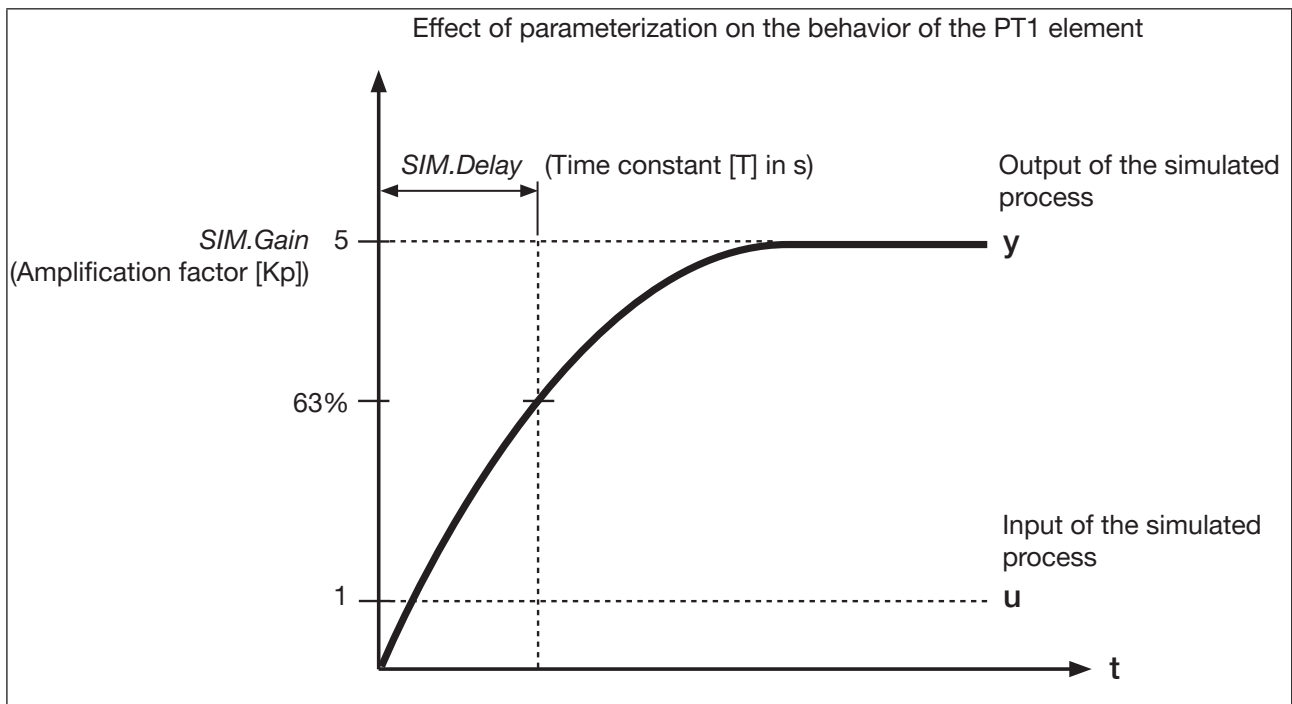




Figure 40: Example of a simulated process. Behavior of the PT1 element

### Simulate the processes and process valve as follows:

-  Press **MENU** for 3 s. Switching from process level ⇒ setting level.
- ▲ / ▼ Select **SIMULATION**. (To do this, the auxiliary function must be incorporated into the main menu).
-  Select **ENTER**. The submenu for setting the simulation is displayed.

→ ▲ / ▼ Select **CONTROL.sim**.


→  Select **ENTER**.

The submenu for activating and parameterizing the process and process valve simulation is displayed.

→ ▲ / ▼ Select required simulation.


Selection  = simulation process.

Selection  = simulation process valve.

→  Select **SELEC**. Activate the selection by checking the box  or deactivate it by unchecking the box .

### Setting the parameters for simulation of the process and/or the process valve:

→ ▲ / ▼ Select **SIM.Gain**. (Amplification factor).

→  Select **INPUT**. The input screen for specifying the amplification factor is opened.

→ ▲ / ▼  Increase value  
 Select decimal place and enter value.

→  Select **OK**. Transfer and simultaneous return to the **CONTROL.sim** menu.

→ ▲ / ▼ Select **SIM.Delay** (period duration in seconds).


→  Select **INPUT**. The input screen for specifying the cycle duration is opened.

→ ▲ / ▼  Increase value  
 Select decimal place and enter value.

→  Select **OK**. Transfer and simultaneous return to the **CONTROL.sim** menu.

→  Select **EXIT**. Return to the **SIMULATION** menu.

→  Select **EXIT**. Return to the main menu (MAIN).

→  Select **EXIT**. Switching from setting level ⇒ process level.

✓ You have simulated the process and process valve.

### 16.1.24 DIAGNOSE – Menu for monitoring valves (option)

The optional function *DIAGNOSE* can be used to monitor the state of the valve. If there are deviations from the set-point state, messages are output according to NE 107.

Example of the output of a diagnostic message:

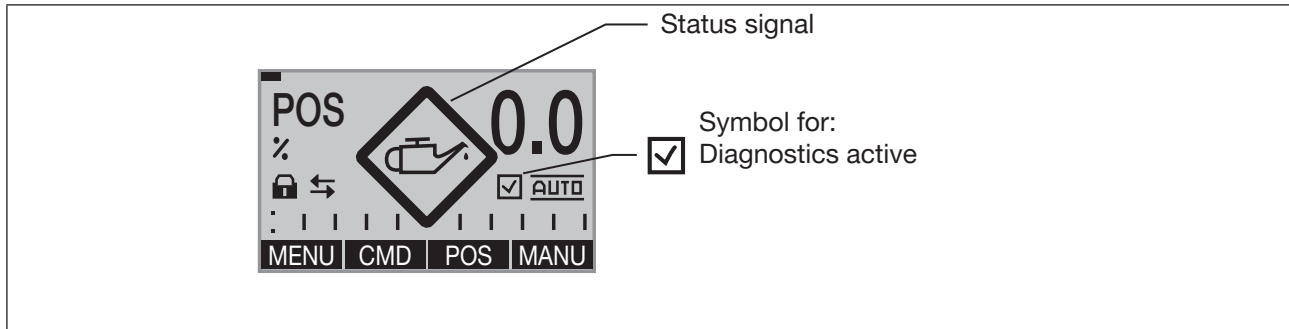


Figure 41: Example of a diagnostic message

#### 16.1.24.1. Activation of the *DIAGNOSE* menu

To ensure that the *DIAGNOSE* menu can be set, it must first be activated in the main menu of the setting level (MAIN) via *ADD.FUNCTION*. See chapter “26.1. Activating and deactivating auxiliary functions”.



The active diagnostics is indicated on the display of the process level with a check mark symbol . See “Figure 83”

#### 16.1.24.2. The *DIAGNOSE* main menu

The *DIAGNOSE* main menu consists of the following submenus.

	<b>D.MSG</b>	(Diagnostic messages) list of all diagnostic messages.
	<b>CONFIG.MSG</b>	Assignment of status signals for different diagnostic messages according to NE 107 (NE = NAMUR recommendation).
	<b>ADD.DIAGNOSE</b>	Activation of diagnostic functions by incorporation into the <i>DIAGNOSE</i> main menu.
	<b>RESET.HISTORY</b>	Deletion of the history entries of all diagnostic functions. The menu is only displayed if the <i>CLOCK</i> function has been selected on the process level.

Table 39: *DIAGNOSE*; main menu

### 16.1.24.3. Activation of diagnostic functions

In the *ADD.DIAGNOSE* menu several diagnostic functions are activated and incorporated into the *DIAGNOSE* main menu.

Activatable diagnostic functions:








<b>HISTOGRAM</b>	Graphical display of the dwell time density and movement range.
<b>SERVICE.TIME</b>	Operating-hours counter
<b>TRAVEL.ACCU</b>	Path accumulator
<b>CYCLE.COUNTER</b>	Direction reversal counter
<b>TEMP.CHECK</b>	Temperature monitor
<b>STROKE.CHECK</b>	Monitoring of the mechanical end positions in the valve
<b>PV.MONITOR</b>	Process actual value monitoring (for Type 8793 only, process control)
<b>POS.MONITOR</b>	Position monitoring

Table 40: *ADD.DIAGNOSE*; overview of diagnostic functions



The description can be found in chapter “26.2.22.5. Description of the *DIAGNOSE* main menu”.

In the *ADD.DIAGNOSE* menu several diagnostic functions are activated and incorporated into the *DIAGNOSE* main menu.


Activate the diagnostic functions as follows:

-  Press **MENU** for 3 s. Switching from process level  $\Rightarrow$  setting level.
-  Select *DIAGNOSE*. (To do this, the *DIAGNOSE* auxiliary function must already have been activated by incorporation into the main menu (MAIN)).
-  Select **ENTER**. The submenus are displayed.
-  Select *ADD.DIAGNOSE*.
-  Select **ENTER**.  
The other diagnostic functions are displayed.
-  Select required diagnostic function
-  Select **ENTER**. The required diagnostic function is now marked by a cross ☒.

Either:

-  Select other diagnostic functions and select  **ENTER**.  
Keep repeating until all required diagnostic functions have been marked with a cross ☒.

Or:

-  Select **EXIT**.  
Acknowledgment and simultaneous return to the *DIAGNOSE* main menu.  
The marked diagnostic functions have been activated and the setting menus are now in the *DIAGNOSE* main menu.

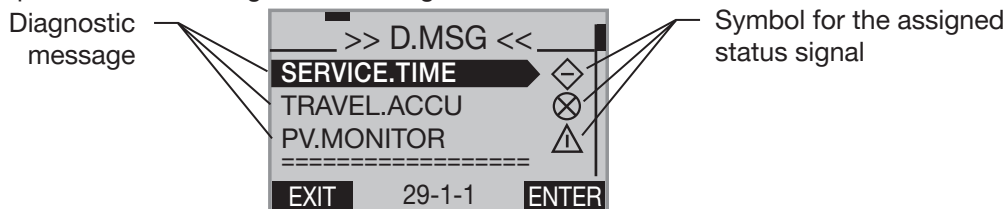
- ✔ You have activated the diagnostic functions.

#### 16.1.24.4. Description of the *DIAGNOSE* main menu

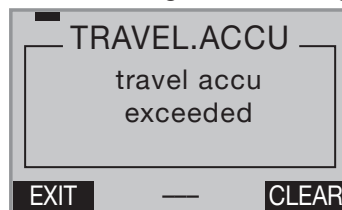
##### 1. **D.MSG** – Diagnostic messages

All generated diagnostic messages are listed in the D.MSG menu where they can be viewed and deleted. The status signal, which is assigned to the diagnostic message, is indicated by a symbol.

Display example of a list with diagnostic messages



Display example of the description text of a diagnostic message



View and delete diagnostic messages as follows:

- ▲ / ▼ Select **D.MSG**.
- Select **ENTER**. All generated diagnostic messages are displayed.
- ▲ / ▼ Select required message
- Select **ENTER**.  
Opening the diagnostic message. The description text is displayed (in English).
- Select **EXIT**.  
Closing the diagnostic message and return to **D.MSG**.

Or:

- Select **CLEAR**. Hold down as long as countdown (5 ...) is running.  
Deleting the diagnostic message and return to **D.MSG**.
- Select **EXIT**.  
Return to the **DIAGNOSE** main menu.

✔ You have viewed and deleted the diagnostic functions.

##### 2. **CONFIG.MSG** – Assignment of status signals according to NE 107 (NAMUR recommendation)

The status signals of the diagnostic messages can be changed in the CONFIG.MSG menu.

The menu indicates only diagnostic functions which can output a message and which have already been activated in the **ADD.DIAGNOSE** menu.

The status signals have different priorities.

If several diagnostic messages are available with different status signals, the status signal with the highest priority is shown on the display.

Overview of the status signals according to NE 107 (NE = NAMUR recommendation):

Priority	1	2	3	4
Status signal				
Meaning	Failure	Function check	Out of specification	Maintenance required

Table 41: CONFIG.MSG; overview of status signals

The following status signals have been preset at the factory for the messages of the diagnostic functions:

Diagnostic function	Status signal according to NE 107	Signal miniature	Priority
SERVICE.TIME	Maintenance required		4
TRAVEL.ACCU	Maintenance required		4
CYCLE.COUNTER	Maintenance required		4
TEMP.CHECK	Out of specification		3
STROKE.CHECK	Out of specification		3
PV.MONITOR	Out of specification		3
POS.MONITOR	Out of specification		3

Table 42: CONFIG.MSG; factory setting (Default)

**Assign the status signals as follows:**

- ▲ / ▼ Select CONFIG.MSG.
- Select ENTER. All activated diagnostic functions, which can output a message, are displayed.
- ▲ / ▼ Select required message.
- Select ENTER.  
The list of possible status signals is displayed.
- ▲ / ▼ Select required message.
- Select SELEC.  
The selected status signal is now marked by a filled circle ●.
- Select EXIT. Acknowledgment and simultaneous return to the CONFIG.MSG menu.  
The status signal is now assigned to the diagnostic function.
- Select EXIT. Return to the DIAGNOSE main menu.
- ✔ You have assigned the status signals.

### 3. **ADD.DIAGNOSE** – Activation and deactivation of diagnostic functions

Diagnostic functions can be activated in this menu and incorporated into the *DIAGNOSE* main menu or already activated diagnostic functions can be deactivated again.

#### Activation of diagnostic functions:

For a description see chapter “[26.2.22.4. Activation of diagnostic functions](#)”

#### Deactivation of diagnostic functions:

The procedure is the same as for activation. Except that with deactivation the cross after the diagnostic function is removed again  by pressing the **ENTER** key.

### 4. **RESET.HISTORY** – Deletion of the history entries of all diagnostic functions

Explanation of the history entries:

There is a history entry for each diagnostic message. This entry is assigned to the diagnostic function, which has actuated this message, and is saved there in the *HISTORY* submenu.





In the menu of some diagnostic functions there is a *HISTORY* submenu in which the history entries are saved.

*RESET.HISTORY* is used to delete the entries of all *HISTORY* submenus.

Individual entries can be deleted in the *HISTORY* submenu of the particular diagnostic function.

See also chapter “[26.2.22.7. History entries in the HISTORY submenu](#)”.

#### Delete all history entries as follows:

- ▲ / ▼ Select **RESET.HISTORY**.
-  Select **RUN** as long as countdown (5 ...) is running.  
All history entries are deleted.
-  Select **EXIT**. Return to the *DIAGNOSE* main menu.

✔ You have deleted the history entries.



History entries are only created when the *CLOCK* function for the display has been activated on the process level.

For activation and setting of *CLOCK* see chapter “[17.4.1. Setting date and time](#)”.



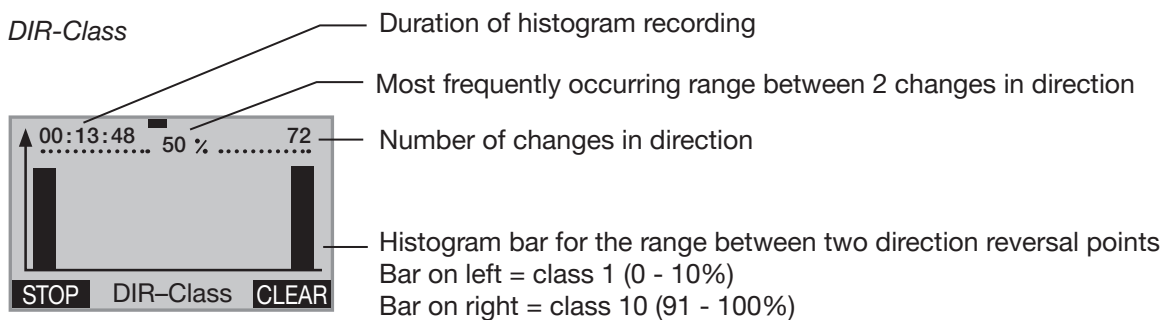
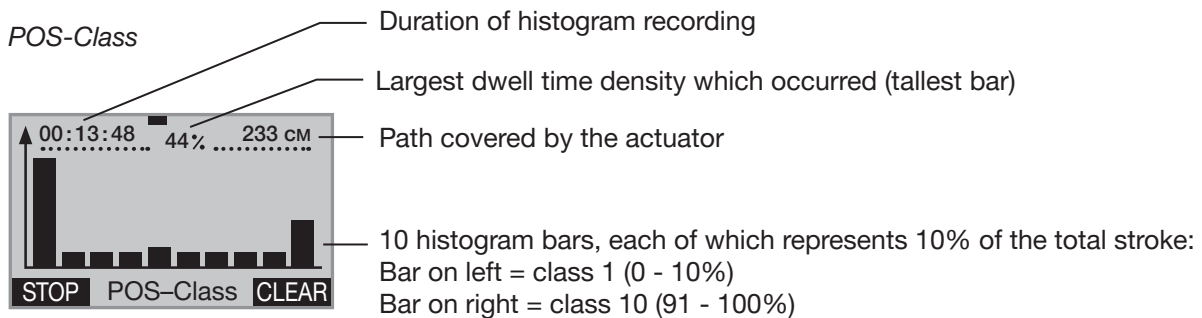
### 16.1.24.5. Description of the diagnostic functions

#### **HISTOGRAM** – Output of histograms

The HISTOGRAM menu is divided into 2 parts:

1. **Outputting the histograms for**  
*POS-Class* (dwell time density) and  
*DIR-Class* (movement range)
2. **List of the characteristic values for**  
 CMD Set-point position valve actuator  
 POS Actual position valve actuator  
 DEV Deviation from POS to CMD  
 TEMP Temperature  
 SP Process set-point value  
 PV Process actual value

Display description of the histograms:



#### **POS-Class - Description of the histogram of the dwell time density**

The histogram indicates how long the actuator has stopped in a specific position.

For this purpose the stroke range is divided into 10 classes.

The current position of one of the 10 classes is assigned to each scan time.

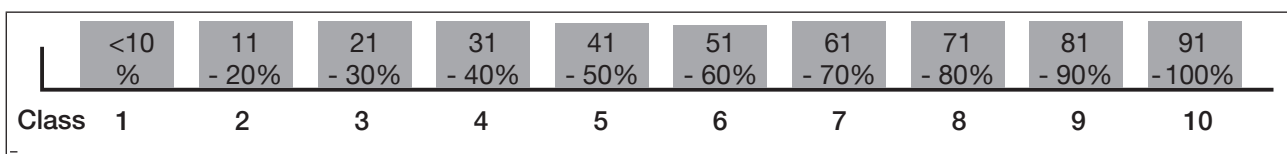


Figure 42: CMD-Class; position classes

**Explanation of the histogram in the example**

Sinusoidal progression of the actuator position:

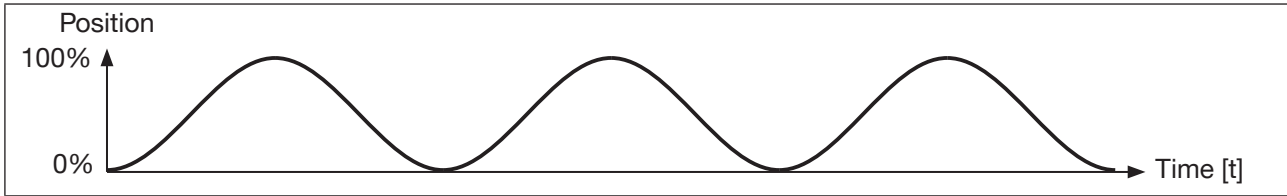


Figure 43: Sinusoidal progression of the actuator position

Histogram of the sinusoidal progression of the actuator position:

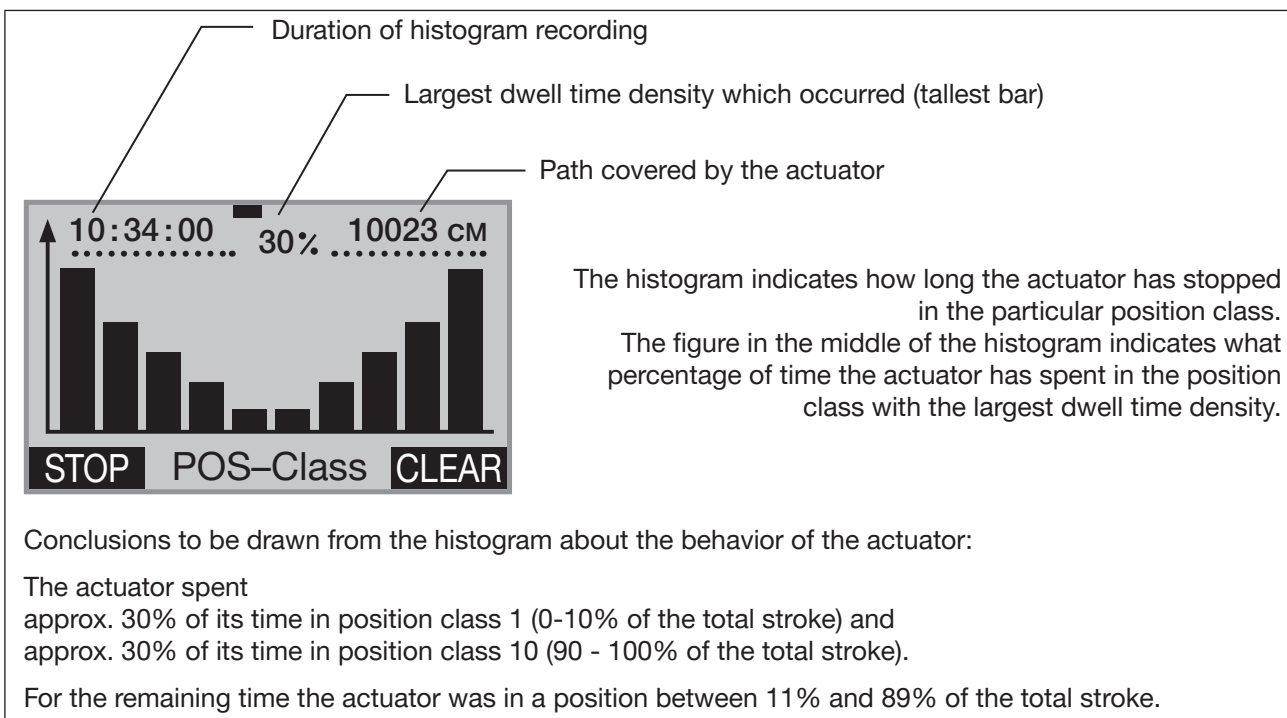


Figure 44: POS-Class; histogram of the dwell time density for sinusoidal progression of the actuator position

**!** The distribution of the histogram allows conclusions to be drawn about the design of the control valve. For example, if the actuator is in the lower stroke range only, the valve has probably been designed too large.

**DIR-Class - Description of the histogram of the movement range**

The histogram indicates the movement ranges of the actuator between two direction reversal points.

For this purpose the movement range between two changes in direction is divided into 10 classes.

The current position of one of the 10 classes is assigned to each scan time.

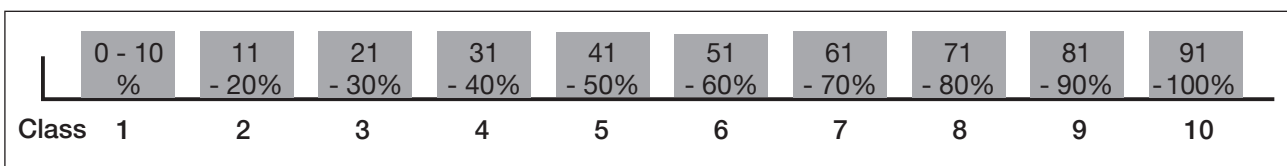


Figure 45: DIR-Class; change in direction classes

MAN 1000341264 EN Version: C Status: RL (released | freigegeben) printed: 09.12.2019

**Explanation of the histogram in the example**

Sinusoidal progression of the actuator position:

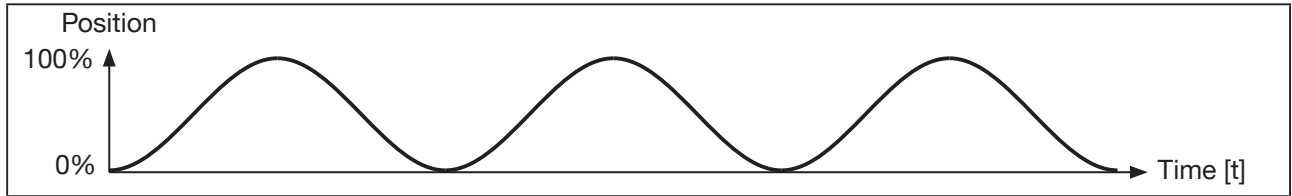


Figure 46: Sinusoidal progression of the actuator position

Histogram of the sinusoidal progression of the actuator position:

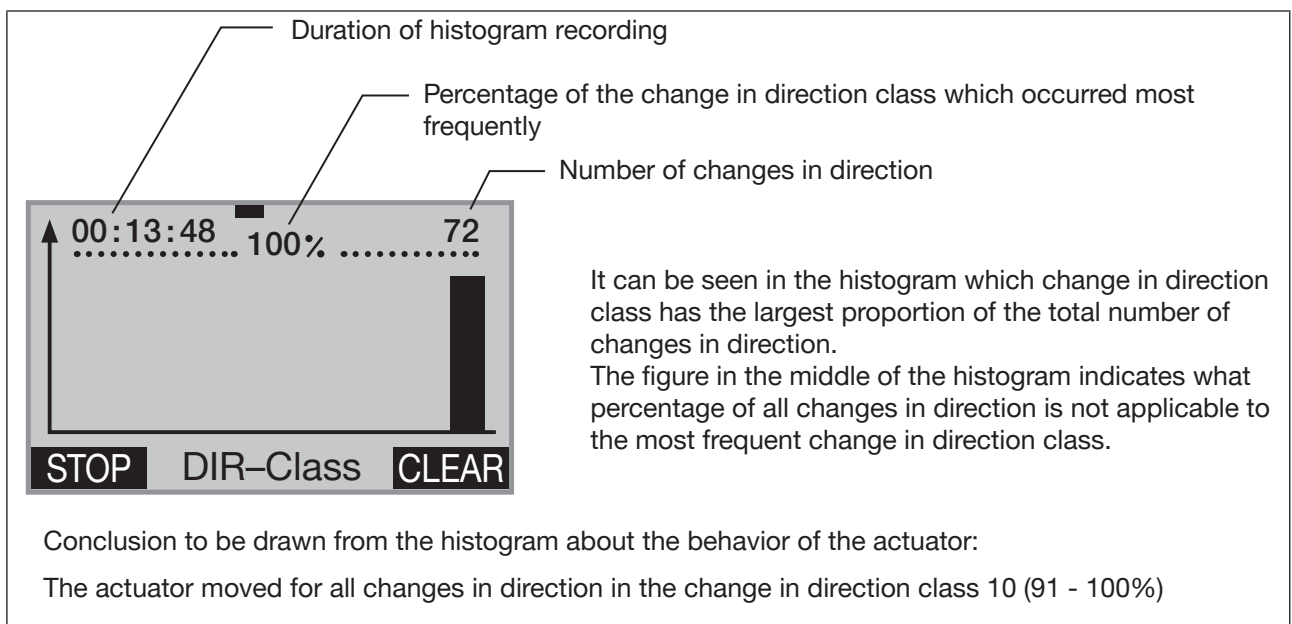


Figure 47: DIR-Class; histogram of the dwell time density for sinusoidal progression of the actuator position



**!** The histograms will only give correct information about the behavior of the actuator when the *X.TUNE* function required for the basic setting has been run.

Start, stop and delete the histograms as follows:



- ▲ / ▼ Select *HISTOGRAM*.  
(To do this, the *HISTOGRAM* function must be incorporated into the *DIAGNOSE* main menu. See chapter "16.1.24.3. Activation of diagnostic functions").
- Select **ENTER**. The empty matrix of the POS-Class submenu (dwell time density) is displayed.

MAN 1000341264 EN Version: C Status: RL (released | freigegeben) printed: 09.12.2019


### Starting histograms:

-  Select **START** \*. Hold down as long as countdown (5 ...) is running.  
Both histograms (*POS-Class* and *DIR-Class*) are started.
-  Change display view.  
Selection options:  
*POS-Class* (Histogram for the dwell time density),  
*DIR-Class* (Histogram for the movement range),  
*SYSTEM-DATA* (list of the characteristic values).




### Stopping histograms:

-  Select **STOP** \*. Hold down as long as countdown (5 ...) is running.  
The recording of both histograms (*POS-Class* and *DIR-Class*) is stopped.
-  Change display view.  
Selection options:  
*POS-Class* (Histogram for the dwell time density),  
*DIR-Class* (Histogram for the movement range),  
*SYSTEM-DATA* (list of the characteristic values).

### Deleting histograms:

-  Select **CLEAR** \*. Hold down as long as countdown (5 ...) is running.  
Both histograms (*POS-Class* and *DIR-Class*) are deleted.

### Return to the *DIAGNOSE* main menu:

-  Select *SYSTEM-DATA*
-  or  Select **EXIT**. Return to the *DIAGNOSE* main menu.

\* The key functions **START**, **STOP** and **CLEAR** are available only in the display views of the histograms *POS-Class* and *DIR-Class*.

- ✔ You have started, stopped and deleted the histograms.

### **SERVICE.TIME** – Operating-hours counter

The operating-hours counter records the time during which the device was switched on.

If the duty cycle reaches the specified time limit, a message is generated.

- To do this, a history entry is made in the *HISTORY* submenu. For a description see [“26.2.22.7. History entries in the HISTORY submenu”](#).
- The status signal, which is assigned to the message, is indicated at short intervals on the display. See also *D.MSG* and *CONFIG.MSG* in chapter [“26.2.22.5”](#) on page 153.

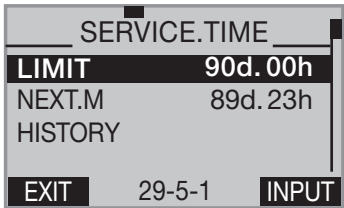




Display <i>SERVICE.TIME</i>	Description of the functions
	<p>The interval for messages preset at the factory for 90 days can be changed in the <i>LIMIT</i> submenu.</p> <p>After <i>NEXT.M</i> the remaining time is displayed until the next message appears.</p> <p>The history entries of the last 3 messages can be viewed and deleted in the <i>HISTORY</i> submenu.</p>

Table 43: *SERVICE.TIME*; operating-hours counter

#### Specify the interval for outputting messages as follows:

- ▲ / ▼ Select *SERVICE.TIME*.  
(To do this, the *SERVICE.TIME* function must be incorporated into the *DIAGNOSE* main menu. See chapter [“16.1.24.3. Activation of diagnostic functions”](#)).
-  Select **ENTER**. The menu is displayed.
- ▲ / ▼ Select *LIMIT*.
-  Select **INPUT**. The preset value is displayed.
- ▲ / ▼ **+** Increase value  
**<-** Changing the (time unit: d/h/m)  
Setting interval for outputting the message.
-  Select **OK**. Return to the *SERVICE.TIME* menu.
-  Select **EXIT**. Return to the *DIAGNOSE* main menu.
- ✔ You have specified the interval for outputting messages.

### **TRAVEL.ACCU** – Path accumulator

The path accumulator records and adds up the path which the actuator piston covers. A movement of the actuator piston is detected when the position changes by at least 1%.

The interval for outputting messages is specified by inputting a limit for the total number of piston movements.

- To do this, a history entry is made in the *HISTORY* submenu. For a description see [“26.2.22.7. History entries in the HISTORY submenu”](#).
- The status signal, which is assigned to the message, is indicated at short intervals on the display. See also *D.MSG* and *CONFIG.MSG* in chapter [“26.2.22.5”](#) on page 154.

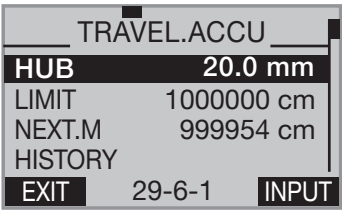





Display <i>TRAVEL.ACCU</i>	Description of the functions
	<p>The <i>HUB</i> submenu specifies the total stroke of the actuator piston. The total stroke is automatically determined during the basic setting of the device (running <i>X.TUNE</i>).</p> <p>In the case of an analog position sensor, the total stroke must be entered by pressing the <b>INPUT</b> key.</p> <p>The interval for outputting the message can be changed in the <i>LIMIT</i> submenu. A piston movement which covers 10 km has been preset at the factory.</p> <p>After <i>NEXT.M</i> the remaining piston movement distance is displayed until the next message appears.</p> <p>The history entries of the last 3 messages can be viewed and deleted in the <i>HISTORY</i> submenu.</p>

Table 44: *TRAVEL.ACCU*; path accumulator

**Specify the interval for outputting messages as follows:**

- ▲ / ▼ Select *TRAVEL.ACCU*.  
(To do this, the *TRAVEL.ACCU* function must be incorporated into the *DIAGNOSE* main menu. See chapter “16.1.24.3. Activation of diagnostic functions”).
-  Select **ENTER**. The menu is displayed.
- \* Required for analog position sensor only (setting the *HUB* submenu)
- ▲ / ▼ Select *HUB*.
-  Select **INPUT** \*. The preset value is displayed.
- ▲ / ▼ **+** Increase value  
**<-** Changing the decimal place  
Setting total stroke of the actuator piston.
- ▲ / ▼ Select *LIMIT*.
-  Select **INPUT** \*. The preset value is displayed.
- ▲ / ▼ **+** Increase value  
**<-** Changing the decimal place  
Setting interval for outputting the message (limit for sum of the piston movement).
-  Select **OK**. Return to the *TRAVEL.ACCU* menu.
-  Select **EXIT**. Return to the *DIAGNOSE* main menu.
- ✔ You have specified the interval for outputting messages.

### **CYCLE.COUNTER** – Direction reversal counter

The direction reversal counter counts the number of changes in direction of the actuator piston. A change in direction is detected when the position of the actuator piston changes by at least 1%.

The interval for outputting messages is specified by inputting a limit for the total number of changes in direction.

- To do this, a history entry is made in the *HISTORY* submenu. For a description see “[26.2.22.7. History entries in the HISTORY submenu](#)”.
- The status signal, which is assigned to the message, is indicated at short intervals on the display. See also *D.MSG* and *CONFIG.MSG* in chapter “[26.2.22.5](#)” on page 155.

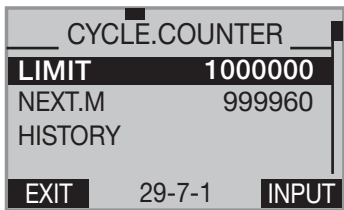




Display <i>CYCLE.COUNTER</i>	Description of the functions
	<p>The interval for outputting the message can be changed in the <i>LIMIT</i> submenu. 1 million changes in direction have been preset at the factory.</p> <p>After <i>NEXT.M</i> the remaining changes in direction are displayed until the next message appears.</p> <p>The history entries of the last 3 messages can be viewed and deleted in the <i>HISTORY</i> submenu.</p>

Table 45: *SERVICE.TIME*; operating-hours counter

#### Specify the interval for outputting messages as follows:

- ▲ / ▼ Select *CYCLE.COUNTER*.  
(To do this, the *CYCLE.COUNTER* function must be incorporated into the *DIAGNOSE* main menu. See chapter “[16.1.24.3. Activation of diagnostic functions](#)”.)
-  Select **ENTER**. The menu is displayed.
- ▲ / ▼ Select *LIMIT*.
-  Select **INPUT**. The preset value is displayed.
- ▲ / ▼ **+** Increase value  
**<-** Changing the decimal place  
Setting interval for outputting the message (limited number of changes in direction).
-  Select **OK**. Return to the *CYCLE.COUNTER* menu.
-  Select **EXIT**. Return to the *DIAGNOSE* main menu.
- ✓ You have specified the interval for outputting messages.

### **TEMP.CHECK** – Temperature monitor

The temperature monitor checks whether the current temperature is within the specified temperature range. The temperature range is specified by inputting a minimum and maximum temperature. If the temperature deviates from the specified range, a message is output.

- To do this, a history entry is made in the *HISTORY* submenu. For a description see “[26.2.22.7. History entries in the HISTORY submenu](#)”.
- The status signal, which is assigned to the message, is indicated at short intervals on the display. See also *D.MSG* and *CONFIG.MSG* in chapter “[26.2.22.5](#)” on page 156.

In addition to the monitor there is a temperature slave pointer. This indicates the lowest and highest of the measured temperature values. The slave pointer can be reset by pressing the **CLEAR** key.

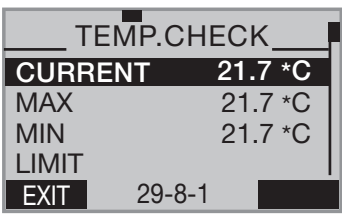









Display <i>TEMP.CHECK</i>	Description of the functions
 <p>TEMP.CHECK</p> <p><b>CURRENT</b> 21.7 °C</p> <p>MAX 21.7 °C</p> <p>MIN 21.7 °C</p> <p>LIMIT</p> <p>EXIT 29-8-1</p>	<p><i>CURRENT</i> indicates the current temperature.</p> <p><i>MAX</i> indicates the highest temperature of the slave pointer</p> <p><i>MIN</i> indicates the lowest temperature of the slave pointer.</p> <p>The permitted temperature range can be changed in the <i>LIMIT</i> submenu. A message is output if the temperature goes outside the permitted range. The temperature range has been preset at the factory from 0...60 °C.</p>
 <p>LIMIT</p> <p><b>HISTORY</b></p> <p>EXIT 29-8-1 ENTER</p>	<p>The history entries of the last 3 messages can be viewed and deleted in the <i>HISTORY</i> submenu.</p>

Table 46: *TEMP.CHECK*; temperature range

**Specify the temperature limit for outputting messages as follows:**

- ▲ / ▼ Select *TEMP.CHECK*.  
(To do this, the *TEMP.CHECK* function must be incorporated into the *DIAGNOSE* main menu. See chapter “16.1.24.3. Activation of diagnostic functions”).
-  Select **ENTER**. The menu is displayed.
- ▲ / ▼ Select *LIMIT*.
-  Select **ENTER**.  
The upper and lower temperature limit is displayed.  
The upper limit *TEMP.MAX* has already been selected.
-  Select **INPUT**. Open input screen for upper temperature limit.
- ▲ / ▼ **+** Increase value  
**<-** Changing the decimal place  
Enter upper temperature limit *TEMP.MAX*.
-  Select **OK**. Acknowledge value.
- ▲ / ▼ Select *TEMP.MIN*.
-  Select **INPUT**. Open factory setting for lower temperature limit.
- ▲ / ▼ **+** Increase value  
**<-** Changing the decimal place  
Enter lower temperature limit *TEMP.MIN*.
-  Select **OK**. Acknowledge value.
-  Select **EXIT**. Return to the *TEMP.CHECK* menu.
-  Select **EXIT**. Return to the *DIAGNOSE* main menu.
- ✔ You have specified the temperature limit for outputting messages.



**STROKE.CHECK** – End position monitor

The *STROKE.CHECK* function is used to monitor the physical end positions of the valve. In this way wear marks can be detected on the valve seat.

To do this, a tolerance band is specified for the lower end position (position 0%) and for the upper end position (position 100%). If an end position exceeds or falls below the tolerance band, a message is output.

- To do this, a history entry is made in the *HISTORY* submenu. For a description see “26.2.22.7. History entries in the *HISTORY* submenu”.
- The status signal, which is assigned to the message, is indicated at short intervals on the display. See also *D.MSG* and *CONFIG.MSG* in chapter “26.2.22.5” on page 158.

In addition to the monitor there is an end position slave pointer. This indicates the minimum and maximum position of the determined end positions. The slave pointer can be reset by pressing the **CLEAR** key.

Display <i>STROKE.CHECK</i>	Description of the functions
	<p><i>MAX</i> indicates the maximum position of the slave pointer</p> <p><i>MIN</i> indicates the minimum position of the slave pointer.</p> <p>The tolerance band for the physical end positions can be set in the <i>LIMIT</i> submenu. A message is output if the temperature goes outside the permitted range.</p> <p>Example:                      Input upper end position <i>TOL MAX</i> = 1%                      If the position is less than -1%, a message is output</p> <p>Input lower end position <i>TOL ZERO</i> = 1%                      If the position is greater than 101%, a message is output</p> <p>The history entries of the last 3 messages can be viewed and deleted in the <i>HISTORY</i> submenu.</p>

Table 47: *STROKE.CHECK*; end position monitor

If a stroke limit was set in the *X.LIMIT* menu, the mechanical end position monitor has only limited relevance.











The end positions indicated on the process level under *POS* are not the physically caused end positions in this case. Therefore they cannot be compared with the end positions indicated in the *STROKE.CHECK* menu under *MIN* and *MAX*.

**Specify the Position limit for outputting messages as follows:**

- ▲ / ▼ Select *STROKE.CHECK*.  
(To do this, the *STROKE.CHECK* function must be incorporated into the *DIAGNOSE* main menu. See chapter “16.1.24.3. Activation of diagnostic functions”).
- Select **ENTER**. The menus are displayed.
- ▲ / ▼ Select *LIMIT*.
- Select **ENTER**.  
The submenus for inputting the lower and upper end position tolerance are displayed.  
The submenu for inputting the lower end position tolerance *ZERO.TOL* has already been selected.
- Select **INPUT**. Open input screen for lower end position tolerance.
- ▲ / ▼ **+** Increase value  
**<-** Changing the decimal place

MAN 1000341264 EN Version: C Status: RL (released | freigegeben) printed: 09.12.2019

Enter lower end position tolerance *ZERO.TOL*.

-  Select **OK**. Acknowledge value.
-  Select *MAX.TOL*.
-  Select **INPUT**. Open input screen for lower end position tolerance.
-   Increase value
-   Changing the decimal place
- Enter upper end position tolerance *MAX.TOL*.
-  Select **OK**. Acknowledge value.
-  Select **EXIT**. Return to the *STROKE.CHECK* menu.
-  Select **EXIT**. Return to the *DIAGNOSE* main menu.
- ✔ You have specified the position limit for outputting messages.

**POS.MONITOR** –Position monitoring

The *POS.MONITOR* function monitors the current position of the actuator.

The tolerance band for the set-point value is specified in the *DEADBAND* submenu.

A period for alignment of the actual value with the set-point value is specified in the *COMP.TIME* submenu (compensation time).

The compensation time *COMP.TIME* starts recording as soon as the set-point value is constant. When the compensation time has elapsed, monitoring starts.

If the control deviation (DEV) of the actual value is greater than the tolerance band of the set-point value during monitoring, a message is output.

- To do this, a history entry is made in the *HISTORY* submenu. For a description see [“26.2.22.7. History entries in the HISTORY submenu”](#).
- The status signal, which is assigned to the message, is indicated at short intervals on the display. See also *D.MSG* and *CONFIG.MSG* in chapter [“26.2.22.5”](#) on page 160.

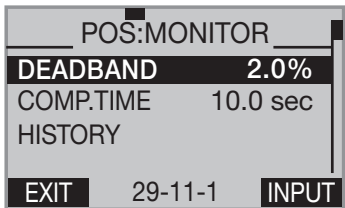
Display <i>POS.MONITOR</i>	Description of the functions
	<p>The tolerance band of the set-point value preset at the factory to 2% can be changed in the <i>DEADBAND</i> submenu.</p> <p>The compensation time is set in <i>COMP.TIME</i> (compensation time).</p> <p>The history entries of the last 3 messages can be viewed and deleted in the <i>HISTORY</i> submenu.</p>

Table 48: *POS.MONITOR*; position monitor

Schematic representation

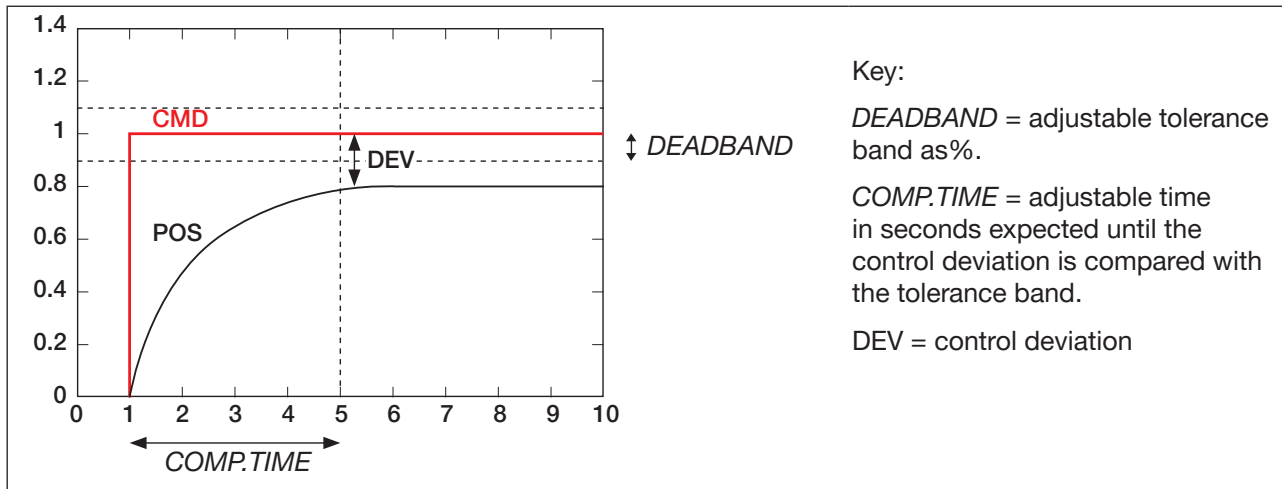








Figure 48: POS.MONITOR; schematic representation of position monitor

#### Set the tolerance band and the compensation time as follows:

- ▲ / ▼ Select **POS.MONITOR**.  
(To do this, the *POS.MONITOR* function must be incorporated into the *DIAGNOSE* main menu. See chapter "16.1.24.3. Activation of diagnostic functions").
-  Select **ENTER**. The menu is displayed. *DEADBAND* has already been selected.
-  Select **INPUT**. The preset value is displayed.
- ▲ / ▼ **+** Increase value  
**<-** Changing the decimal place  
Enter tolerance band.
-  Select **OK**. Acknowledge value.
- ▲ / ▼ Select **COMP.TIME**.
-  Select **INPUT**. The preset value is displayed.
- ▲ / ▼ **+** Increase value  
**<-** Changing the decimal place  
Enter compensation time.
-  Select **OK**. Return to the *POS.MONITOR* menu.
-  Select **EXIT**. Return to the *DIAGNOSE* main menu.
- ☑ You have specified the tolerance band and the compensation time.

#### **PV.MONITOR** – Process monitor (for Type 8793 only)

The *PV.MONITOR* function monitors the process actual value.

The operating menu is identical to the position monitor *POS.MONITOR* described above. In contrast, it is not the position of the actuator which is monitored here but the process.

### 16.1.24.6. History entries in the *HISTORY* submenu

Each diagnostic function, which can output a message, has the *HISTORY* submenu.

When the diagnostic message is actuated, a history entry is created with date and value. The history entries of the respective diagnostic function can be viewed and deleted in the *HISTORY* submenu.

A maximum of three history entries are stored from each diagnostic message. If three history entries are already available when a message is actuated, the oldest history entry is deleted.

Example: History of the diagnostic function *TRAVEL.ACCU*

TRAVEL.ACCU	
DATE	VALUE
01.02.12	5 cm
01.02.12	35 cm
01.02.12	10 cm
<b>EXIT</b>	<b>CLEAR</b>

Description:

On the left of the display is the date and on the right the associated value.

Deleting the history:

Hold down the **CLEAR** key until the countdown (5...) is running.



The *RESET.HISTORY* diagnostic menu can be used to jointly delete the histories of all diagnostic functions. See chapter "26.2.22.5".

Delete the histories of a diagnostic function (example *TRAVEL.ACCU*) as follows:

- ▲ / ▼ Select *TRAVEL.ACCU*.
- Select **ENTER**. The menu is displayed.
- ▲ / ▼ Select *HISTORY*.
- Select **INPUT**. History entries with date and value are displayed.
- Select **CLEAR**. Hold down as long as countdown (5 ...) is running. The histories of the *TRAVEL.ACCU* diagnostic function are deleted.
- Select **EXIT**. Return to the *TRAVEL.ACCU* menu.
- Select **EXIT**. Return to the *DIAGNOSE* main menu.

✓ You have deleted the histories of the diagnostic function.



History entries are only created when the *CLOCK* function for the display has been activated on the process level.

**To receive correct history entries, date and time must be correct.**

Date and time must be reset after a restart. Therefore, the device switches immediately and automatically to the corresponding menu after a restart.

For activation and setting of *CLOCK* see chapter "17.4.1. Setting date and time:"

## 16.2 Manual configuration of X.TUNE



This function is required for special requirements only.


For standard applications the X.TUNE function has been preset at the factory. See chapter “23.2. X.TUNE – Automatic adjustment of the position controller”.

For special requirements the X.TUNE function, as described below, can be manually configured.

Open the menu for the manual configuration of X.TUNE as follows:

→  Press **MENU** for 3 s. Switching from process level ⇒ setting level.

→  Select X.TUNE.

→  Select **RUN**. Opening the *Manual.TUNE* menu. The menu options for the manual configuration of X.TUNE are displayed.

✓ You have opened the menu for the manual configuration of X.TUNE.




### 16.2.1 Description of the menu for the manual configuration of X.TUNE

<b>X.TUNE.CONFIG</b>	Configuration of the X.TUNE function	Specify which functions are to be executed when X.TUNE is running (automatic self-optimization).
<b>M.TUNE.POS</b>	Position of the end positions	<ul style="list-style-type: none"> <li>- Specify whether the pneumatic actuator has mechanical end positions.</li> <li>- Manual specification of the end positions</li> </ul> If there are no mechanical end positions available, these are not approached by the X.TUNE and must be manually specified.
<b>M.TUNE.PWM</b>	Optimization of the PWM signals	Manual optimization of the PWM signals for control of the aeration valves and bleed valves.  For optimization the valves must be aerated and bled. A progress bar on the display indicates the speed at which the valve is aerated or bled. The setting is optimum when the progress bar moves as slowly as possible.
<b>M.TUNE.AIR</b>	Determination of the opening and closing times of the actuator	Continuous determination of the opening and closing times of the actuator.

### 16.2.1.1. X.TUNE.CONFIG – Configuration of the X.TUNE function

In this menu you can specify which functions are to be executed when the X.TUNE function is running automatically.


Specify the functions in X.TUNE.CONFIG as follows:

- ▲ / ▼ Select X.TUNE.CONFIG.
-  Select **ENTER**. The functions for automatic self-parameterization by X.TUNE are displayed.
- ▲ / ▼ Select required function.
-  Select **SELEC**. Activate the function by checking the box .
- Select required functions in succession using the arrow keys ▲ / ▼ and activate by checking the box .
-  Select **EXIT**. Return to the Manual.TUNE menu.
- ✔ You have specified the functions in X.TUNE.CONFIG.



### 16.2.1.2. X.TUNE.POS – Setting of the end positions

In this menu you can specify whether the pneumatic actuator has mechanical end positions or not. If there are no mechanical end positions available, these are not approached by the X.TUNE and must be manually specified.




Set the end position as follows:






- ▲ / ▼ Select M.TUNE.POS.
-  Select **ENTER**.  
The selection for  
ACT.limit = mechanical end positions available  
ACT.nolimit = mechanical end positions not available  
is displayed.

If mechanical end positions are available

- ▲ / ▼ Select ACT.limit.
-  Select **SELEC**. The selection is marked by a filled circle .
-  Select **EXIT**. Return to the Manual.TUNE menu.

If mechanical end positions are not available

- ▲ / ▼ Select ACT.nolimit.
-  Select **SELEC**. The CAL.POS submenu for inputting the end positions is opened.
- ▲ / ▼ Select POS.pMIN.
-  Select **INPUT**. The input screen for the value of the lower end position is opened.
- ▲ / ▼ **OPN** Increase value  
**CLS** Changing the decimal place  
Approach lower end position of the valve.
-  Select **OK**. Transfer and simultaneous return to the CAL.POS menu.
- ▲ / ▼ Select POS.pMAX.

-  Select **INPUT**. The input screen for the value of the upper end position is opened.
-  **OPN** Increase value  
**CLS** Changing the decimal place  
 Approach upper end position of the valve.
-  Select **OK**. Transfer and simultaneous return to the *CAL.POS* menu.
-  Select **EXIT**. Return to the *M.TUNE.POS.* menu.
-  Select **EXIT**. Return to the *Manual.TUNE* menu.
- ✔ You have set the end position.

### 16.2.1.3. *M.TUNE.PWM* – Optimization of the PWM signals

In this menu the PWM signals for control of the aeration valves and bleed valves are manually optimized.

For optimization the actuator is aerated and bled. A progress bar on the display indicates the position of the actuator and the speed of aeration and deaeration.

The setting is optimum when the progress bar moves as slowly as possible.









#### **WARNING**

Danger due to uncontrolled valve movement when the *M.TUNE.PWM* function is running.

When the *M.TUNE.PWM* function is running under operating pressure, there is an acute risk of injury.

- ▶ Never run *X.TUNE.PWM* while a process is running.
- ▶ Secure the device against accidental activation.

Optimize the PWM signals as follows:

-  Select *M.TUNE.PWM*.
-  Select **ENTER**.  
 The submenu is displayed.  
*yB.min* = aeration valve  
*yE.min* = bleed valve
-  Select *yB.min*. Submenu for setting the PWM signal for the aeration valve.
-  Select **ENTER**. The input screen for setting the PWM signal is opened.  
 The progress bar indicates the speed of aeration.
-  **+** Increase speed  
**-** Reduce speed  
 Minimize speed so that the progress bar moves as slowly as possible from left to right.  
**Note:** Do not minimize speed to such an extent that the progress bar remains in one position.
-  Select **OK**. Transfer and simultaneous return to the *M.TUNE.PWM* menu.
-  Select *yE.min*. Submenu for setting the PWM signal for the bleed valve.
-  Select **ENTER**. The input screen for setting the PWM signal is opened.  
 The progress bar indicates the speed of deaeration.


- ▲ / ▼ **+** Increase speed
- Reduce speed

Minimize speed so that the progress bar moves as slowly as possible from right to left.

**Note:** Do not minimize speed to such an extent that the progress bar remains in one position.

-  Select **OK**. Transfer and simultaneous return to the *M.TUNE.PWM* menu.

-  Select **EXIT**. Return to the *Manual.TUNE* menu.

 You have optimized the PWM signal.

#### 16.2.1.4. *M.TUNE.AIR* – Determination of the opening and closing times


By running this function, the opening and closing times of the valve are determined continuously.

A change to the supply pressure will affect the aeration time which can be optimized in this way.

For the setting the effects, which a change to the supply pressure has on the aeration time, can be continuously monitored via the *M.TUNE.AIR* function.

**Continuously determine the opening and closing times as follows:**

- ▲ / ▼ Select *M.TUNE.AIR*.

-  Select **RUN**. Hold down as long as countdown (5 ...) is running.

The aeration and deaeration times are displayed.

*time.open* = aeration


*time.close* = deaeration

Change the supply pressure to adjust the aeration time.

The changed aeration time is displayed continuously.

-  Select **EXIT**. Return to the *Manual.TUNE* menu.

-  Select **EXIT**. Return to the main menu (MAIN).

-  Select **EXIT**. Switching from setting level ⇒ process level.

 You have continuously determined the opening and closing times.



# 17 ACCESS TO THE BÜS SERVICE INTERFACE

The bÜS service interface is located inside the device.

→ Remove the housing cover for access.

→ Ensure that a terminating resistor is used.

## NOTE

Connect the Micro-USB to the PC always via the bÜS adapter.

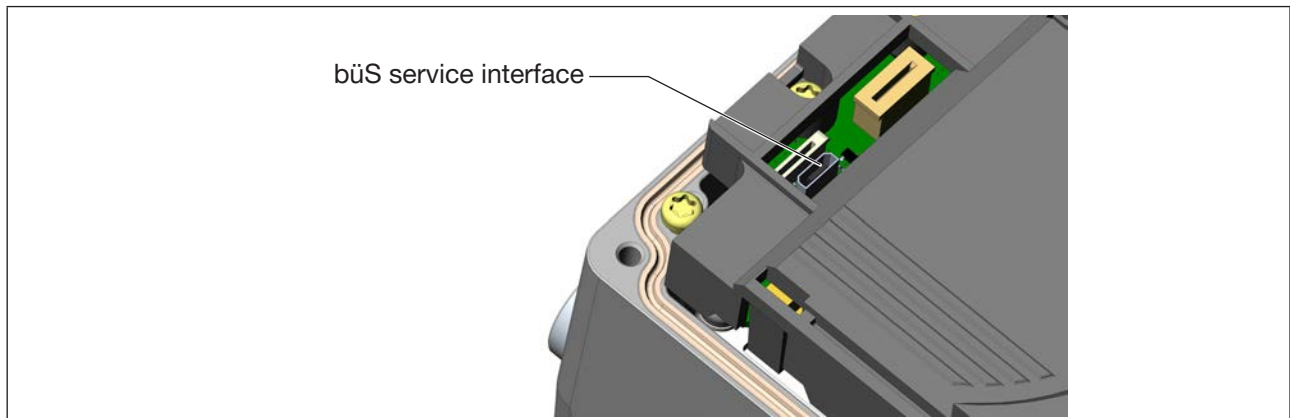


Figure 49: bÜS service interface

## 17.1 Setting options for start-up via Bürkert-Communicator

- Setting with the Bürkert-Communicator PC software on the PC

This type of setting is possible for all device types and device versions.

To do this, the device must be connected using the USB-bÜS interface sets and the bÜS service interface.

**!** The PC software Bürkert-Communicator can be downloaded free of charge from the Bürkert homepage.

To do this, the USB bÜS interface set, available as an accessory, is required. Communication is established by the bÜS Service interface of the device (see chapter “22 Accessories”)

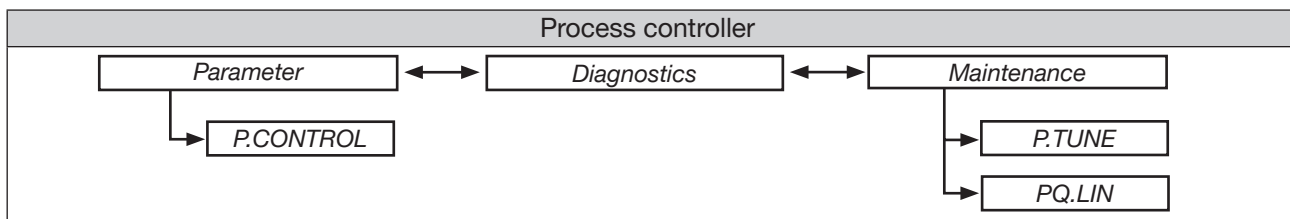


Table 49: Process controller level

MAN 1000341264 EN Version: C Status: RL (released | freigegeben) printed: 09.12.2019

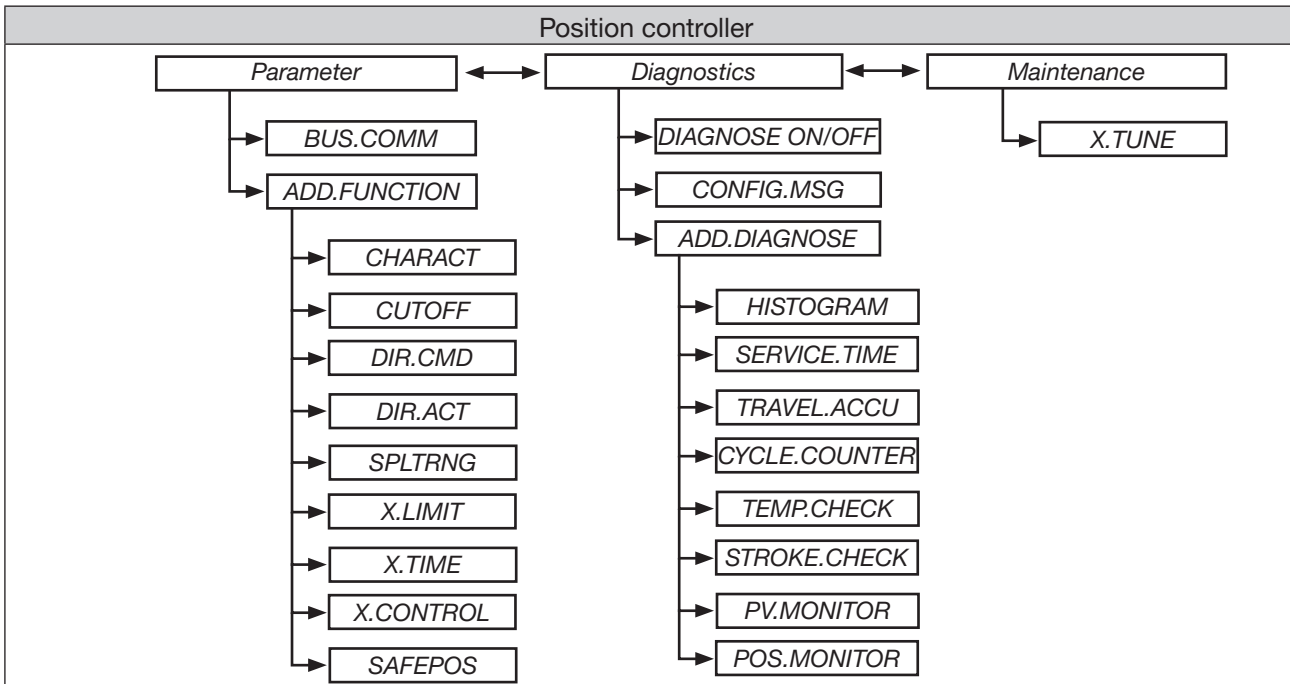


Table 50: Position controller level

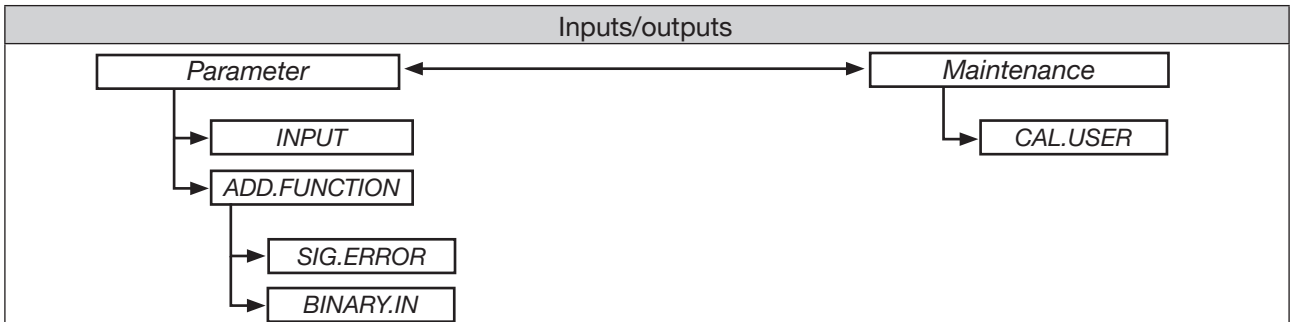


Table 51: Inputs/outputs level

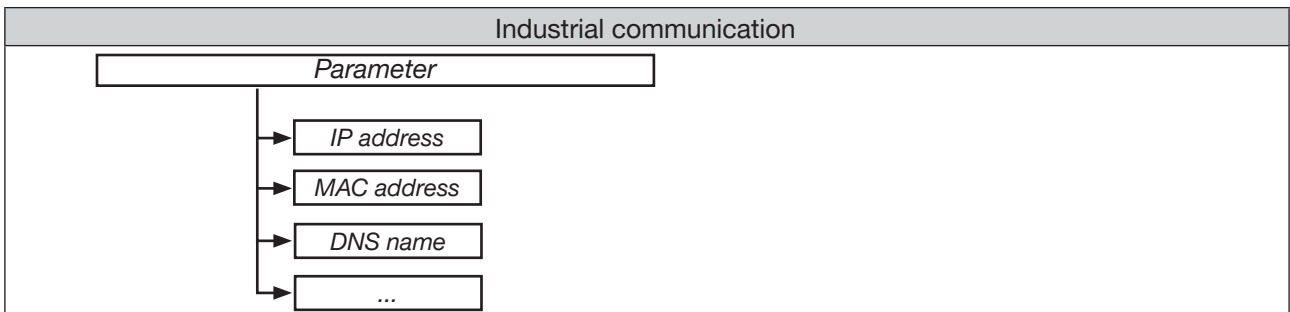


Table 52: Inputs/outputs level (for Ethernet device only)

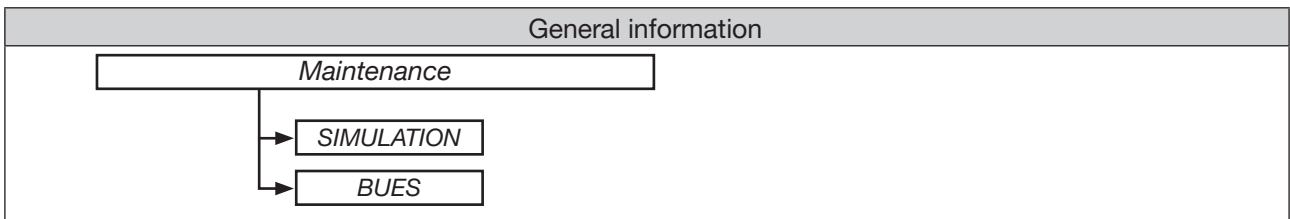


Table 53: General level

MAN 1000341264 EN Version: C Status: RL (released | freigegeben) printed: 09.12.2019

# 18 OPERATING STRUCTURE AND FACTORY SETTING

The factory presets are highlighted in blue to the right of the menu in the operating structure. Examples:

<input checked="" type="radio"/> / <input checked="" type="checkbox"/>	Menu options activated or selected at the factory
<input type="radio"/> / <input type="checkbox"/>	Menu options not activated or selected at the factory
2%, 10 sec, ...	Values set at the factory

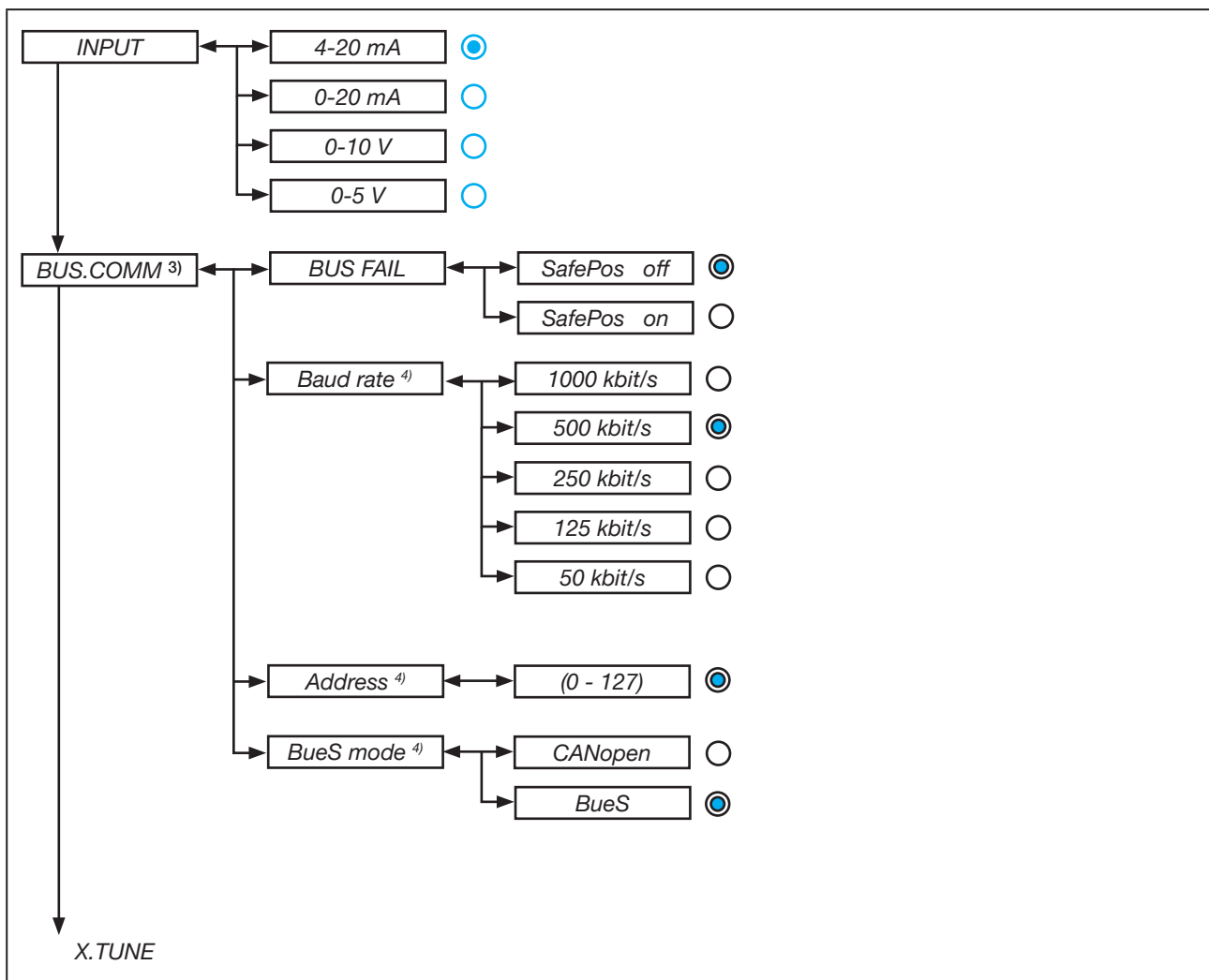


Figure 50: Operating structure - 1

3) Only for fieldbus  
 4) Only for BUES devices

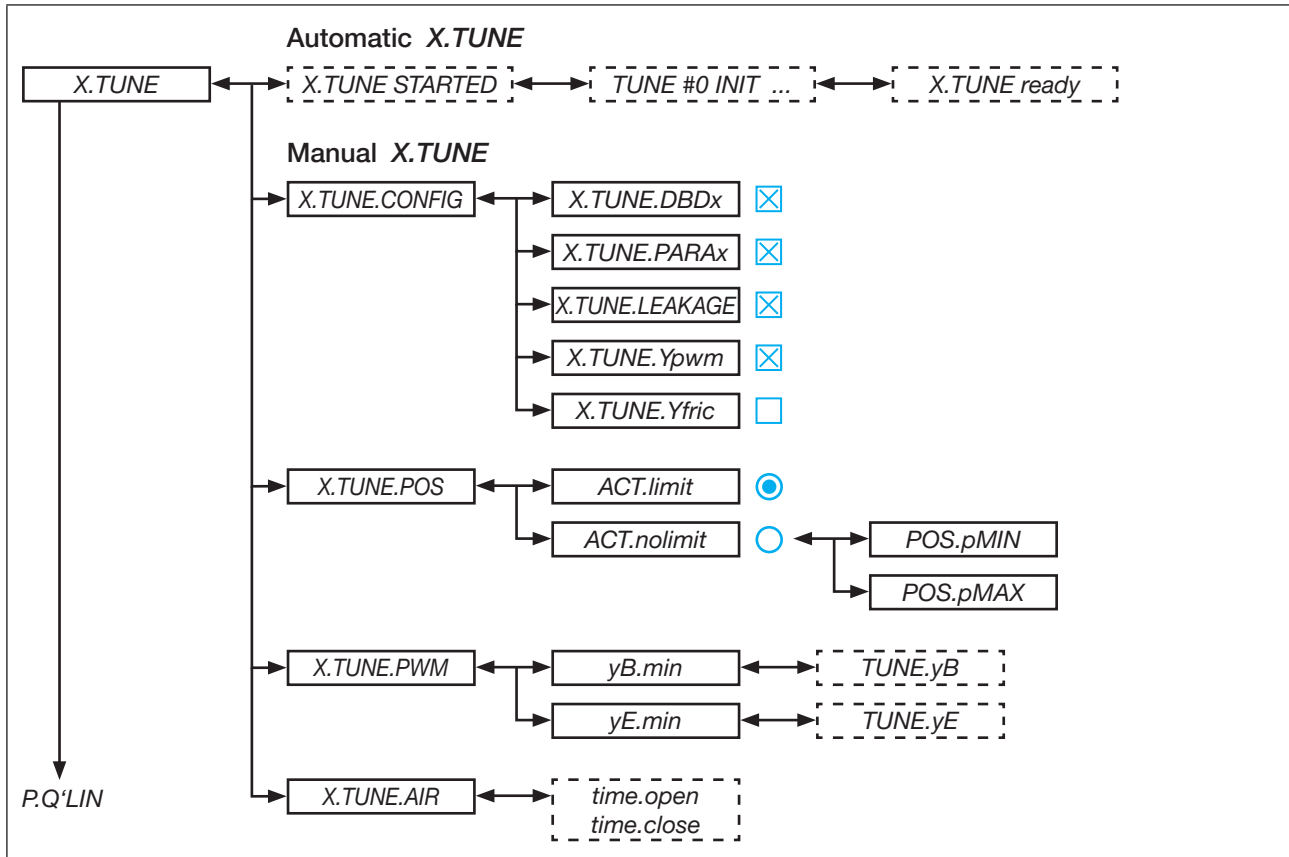
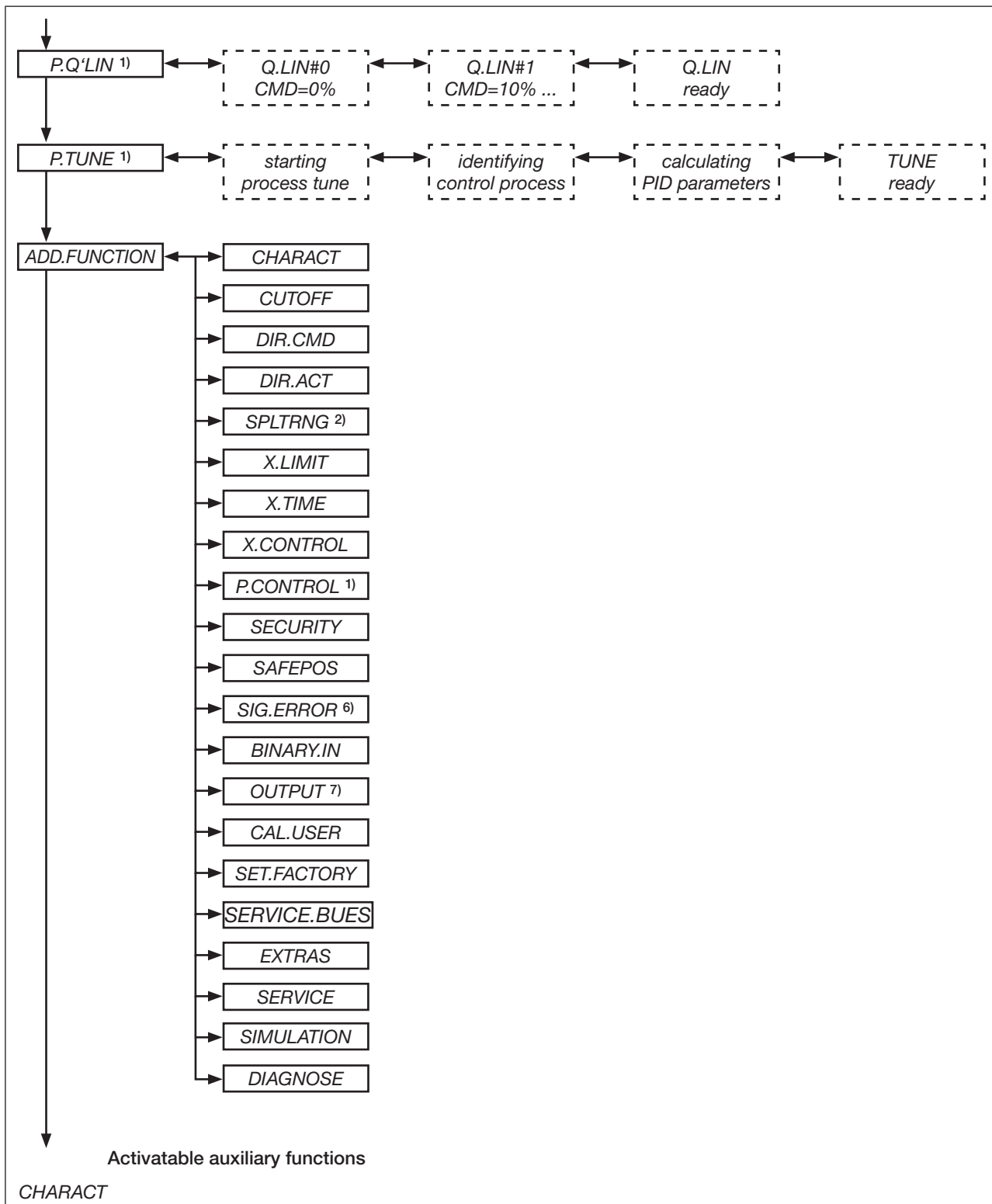


Figure 51: Operating structure - 2



MAN 1000341264 EN Version: C Status: RL (released | freigegeben) printed: 09.12.2019

Figure 52: Operating structure - 3

- 1) Only process controller Type 8793
- 2) Only for position controller mode
- 6) Only for signal type 4...20 mA and Pt 100
- 7) Optional. The number of outputs varies depending on the variant.

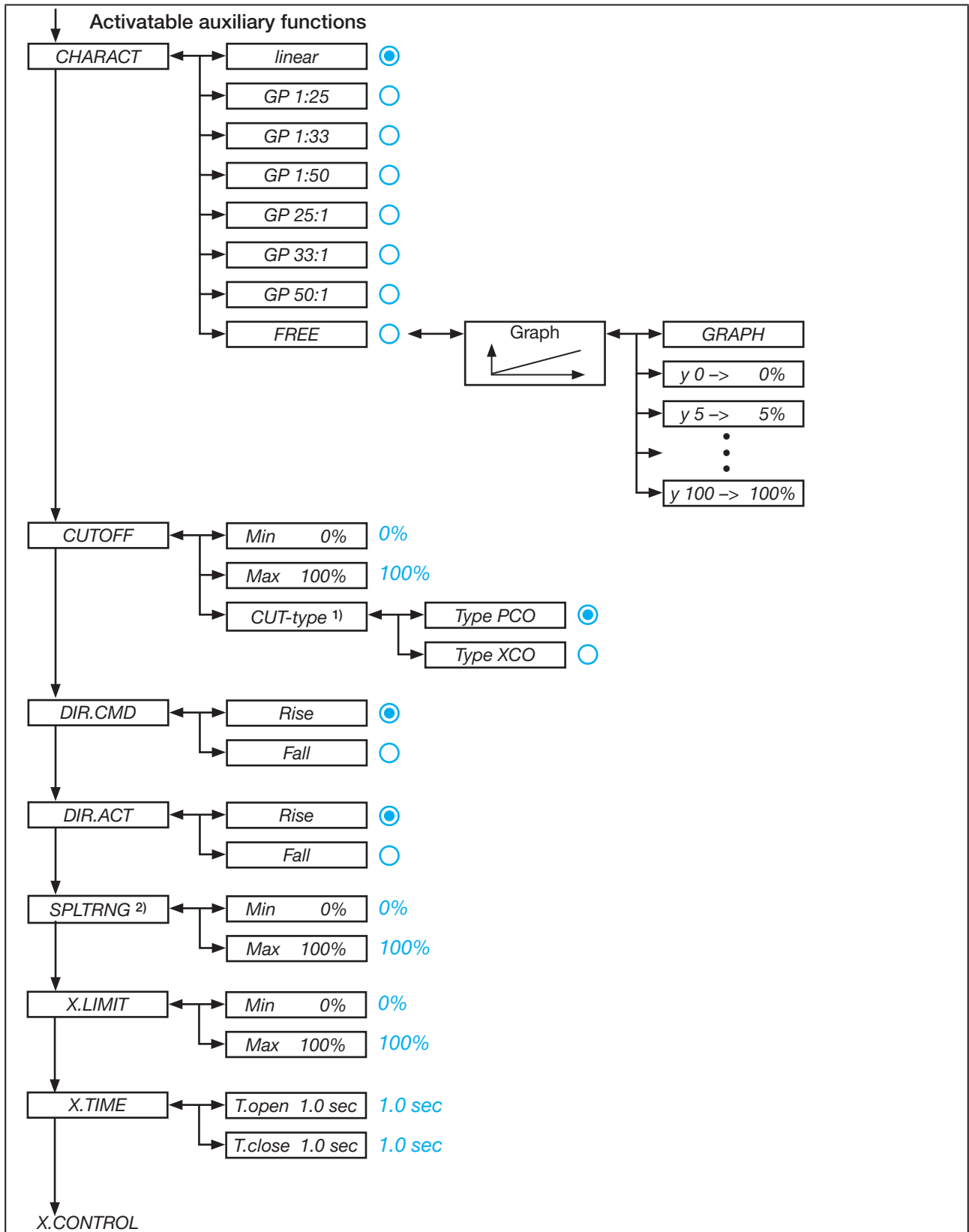


Figure 53: Operating structure - 4

1) Only process controller Type 8793

2) Only for position controller mode

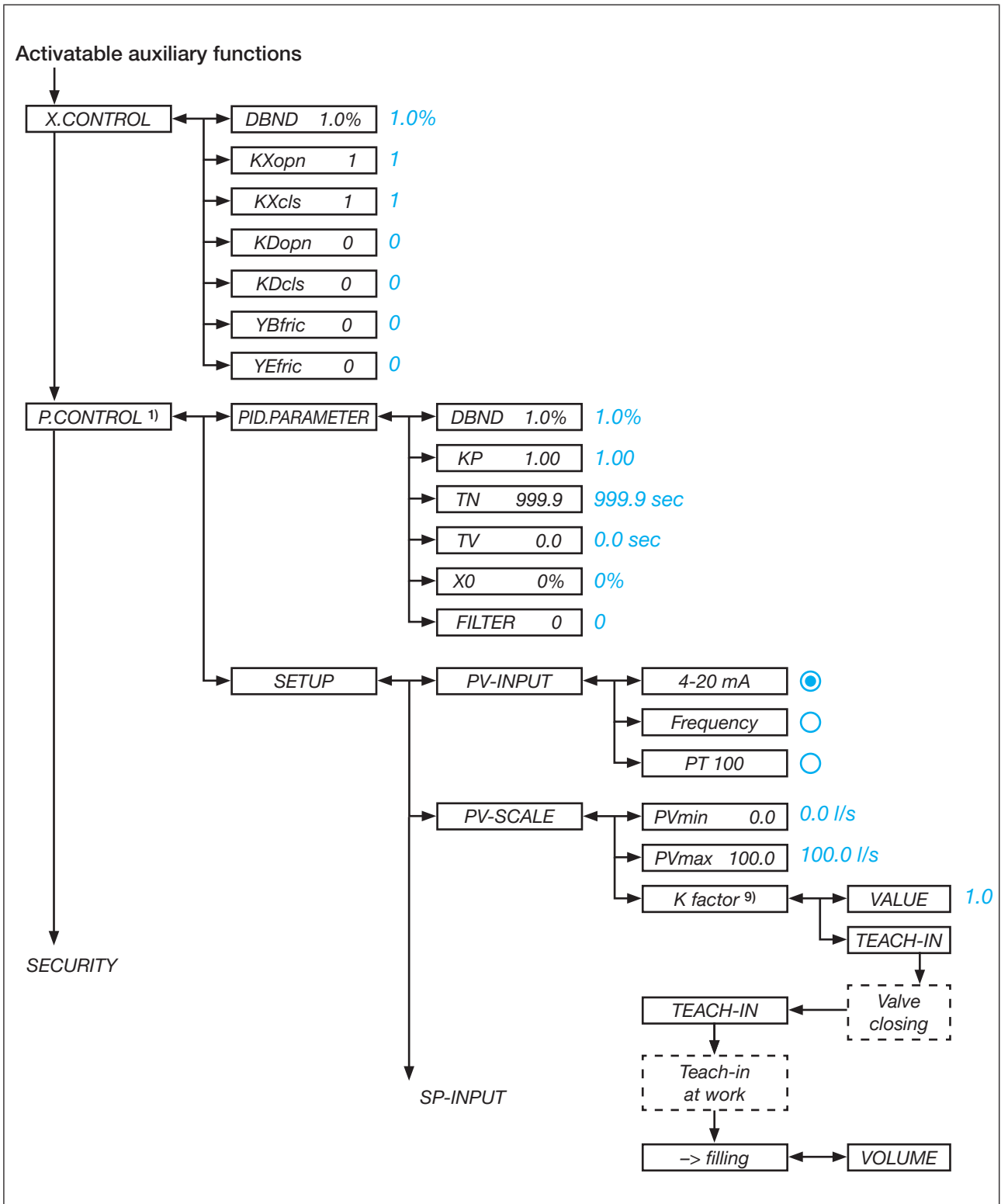


Figure 54: Operating structure - 5

1) Only process controller Type 8793

MAN 1000341264 EN Version: C Status: RL (released | freigegeben) printed: 09.12.2019

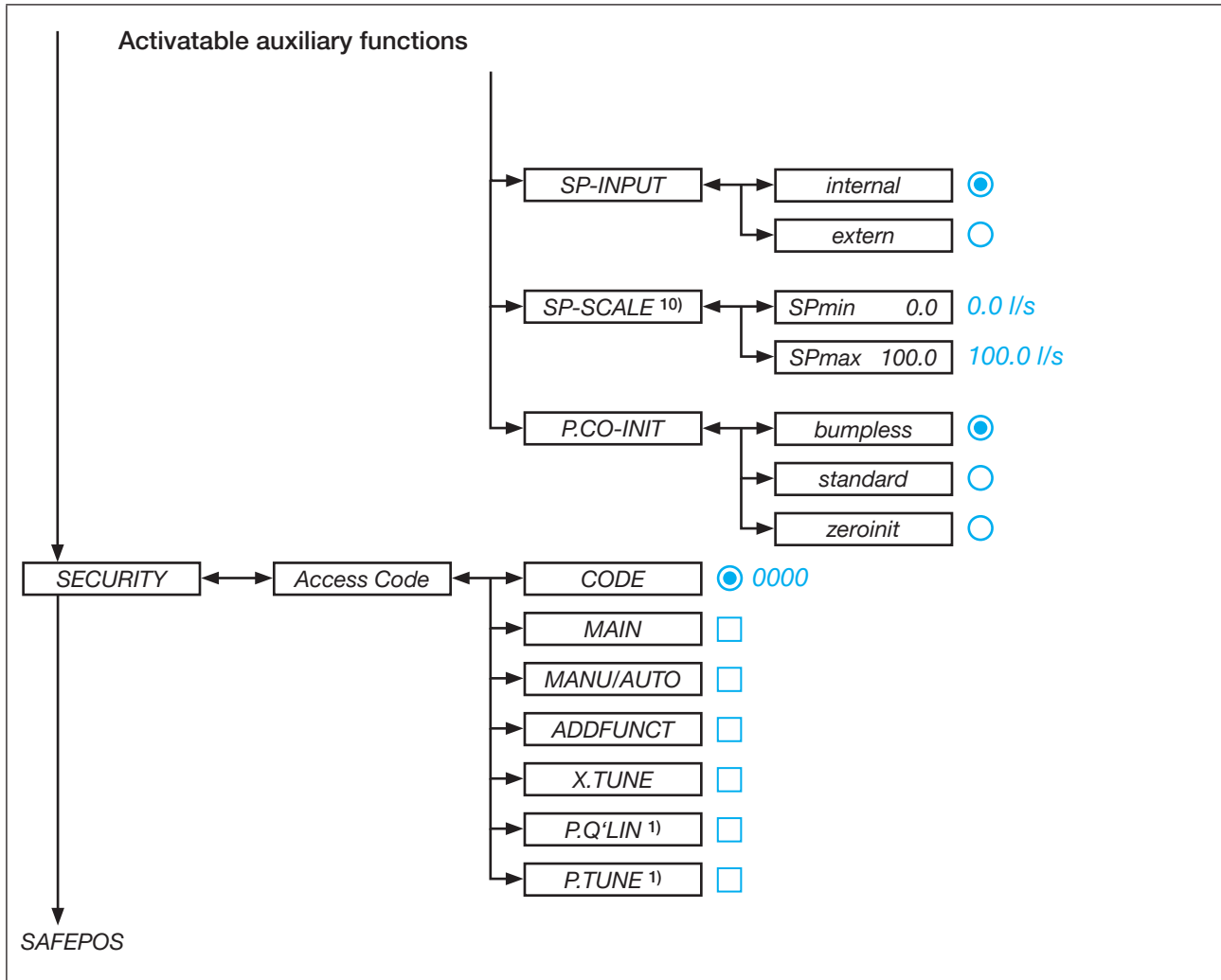


Figure 55: Operating structure - 6

1) Only process controller Type 8793

9) Only for signal type frequency (P.CONTROL → SETUP → PV-INPUT → frequency)

10) Only process controller Type 8793 and for external set-point value default (P.CONTROL → SETUP → SP-INPUT → external)



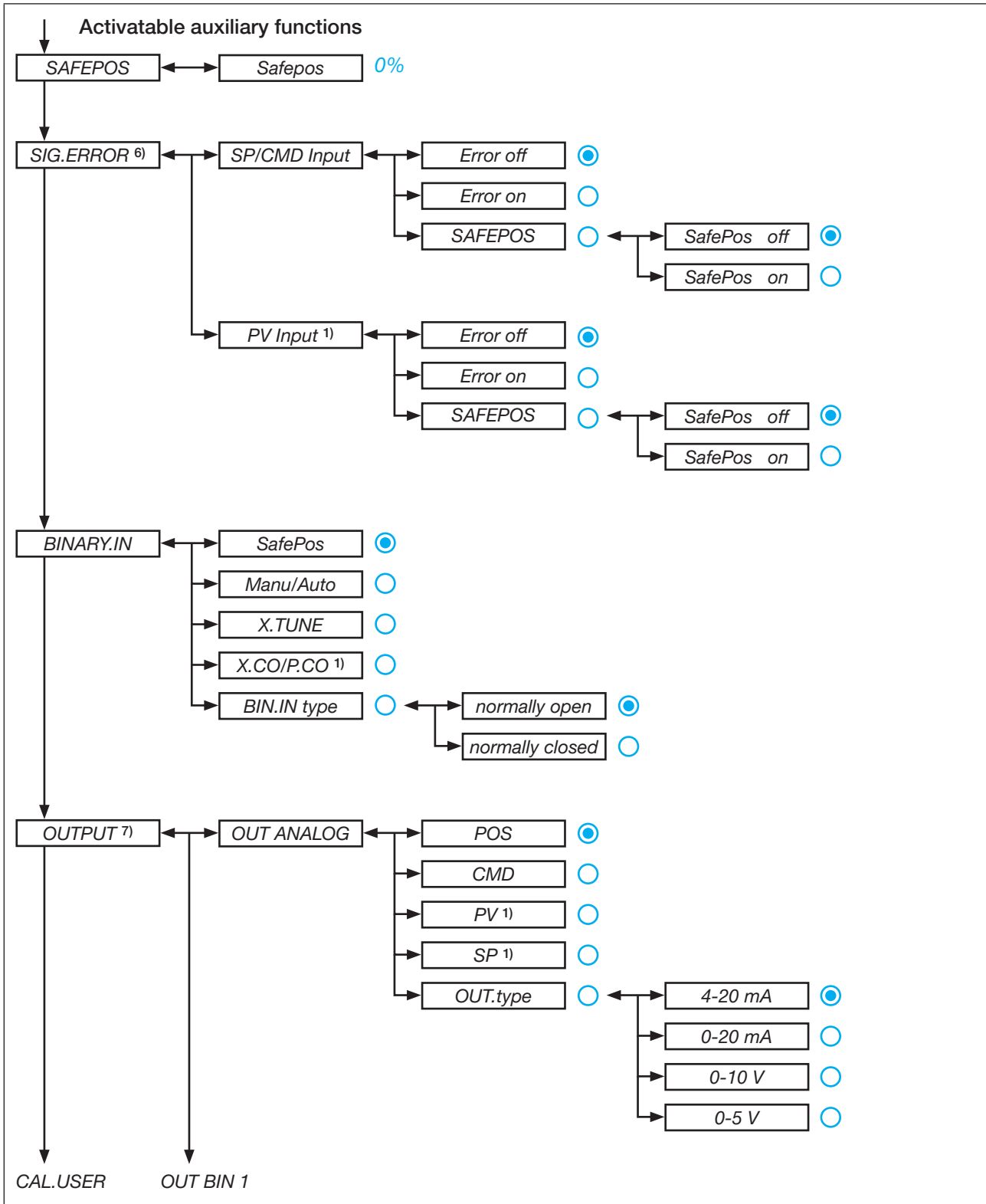


Figure 56: Operating structure - 7

1) Only process controller Type 8793  
 6) Only for signal type 4...20 mA and Pt 100  
 7) Optional. The number of outputs varies depending on the variant.

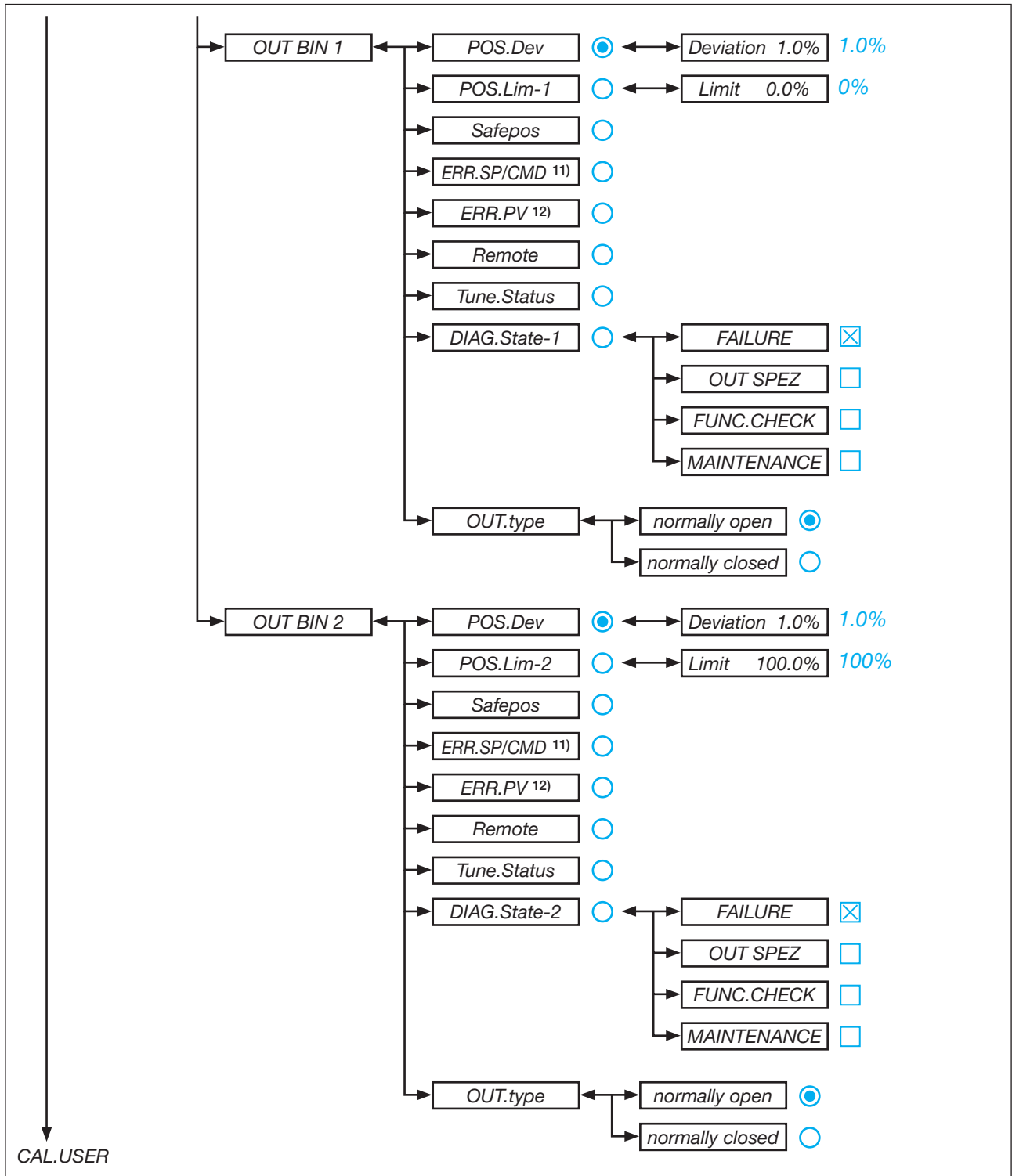


Figure 57: Operating structure - 8

- 11) Only if fault detection is activated for the input signal (SIG.ERROR → SP/CMD Input or PV-Input → Error on)
- 12) Only process controller Type 8793 and if fault detection is activated for the input signal (SIG.ERROR → SP/CMD Input or PV-Input → Error on)

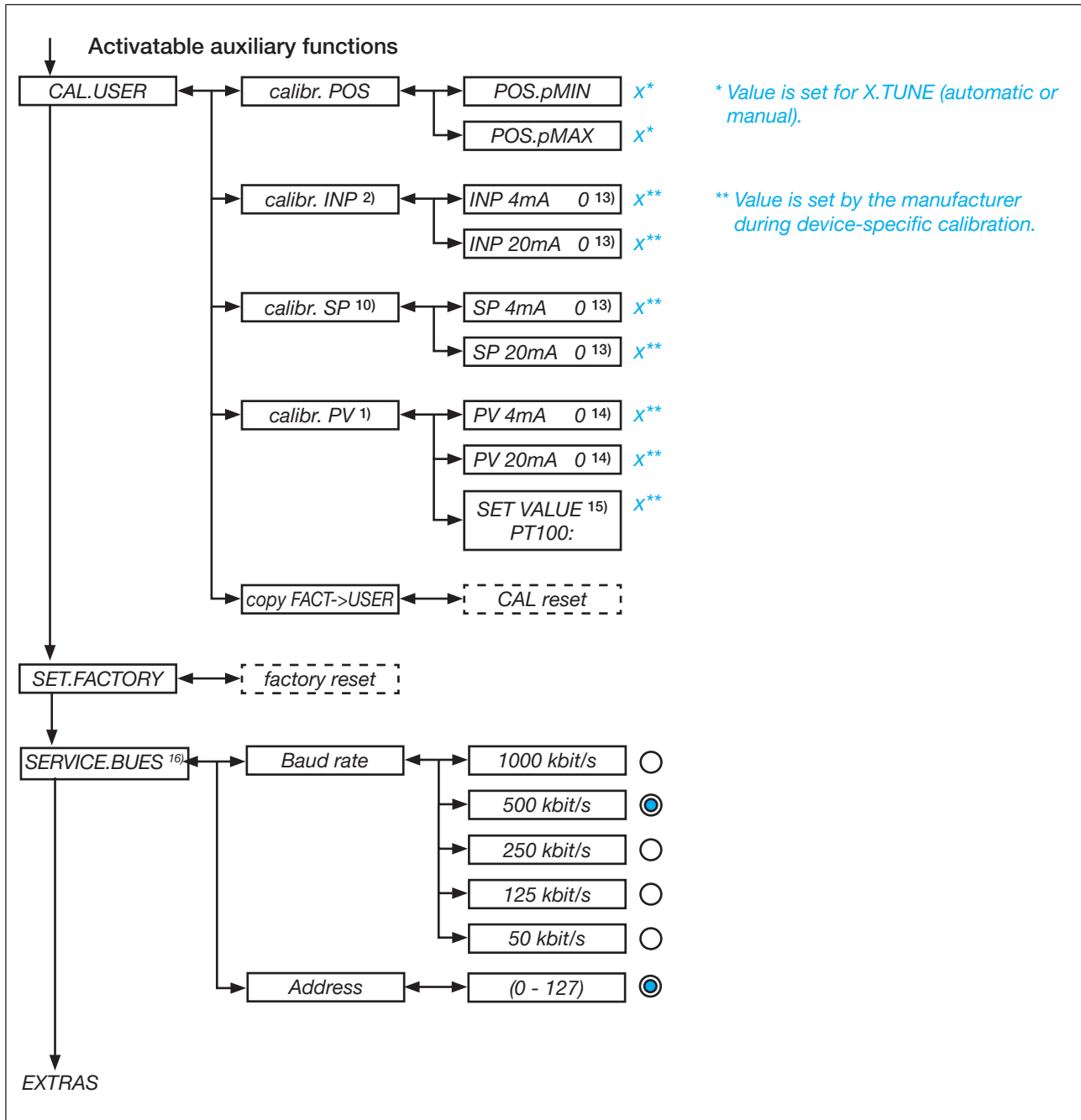


Figure 58: Operating structure - 9

- 1) Only process controller Type 8793
- 2) Only for position controller mode
- 10) Only process controller Type 8793 and for external set-point value default (P.CONTROL → SETUP → SP-INPUT → external)
- 13) The signal type is displayed which is selected in the INPUT menu
- 14) Only for signal type 4...20 mA (P.CONTROL → SETUP → PV-INPUT → 4...20 mA)
- 15) Only for circuit with Pt 100 (P.CONTROL → SETUP → PV-INPUT → PT 100)
- 16) Only for devices other than BUES

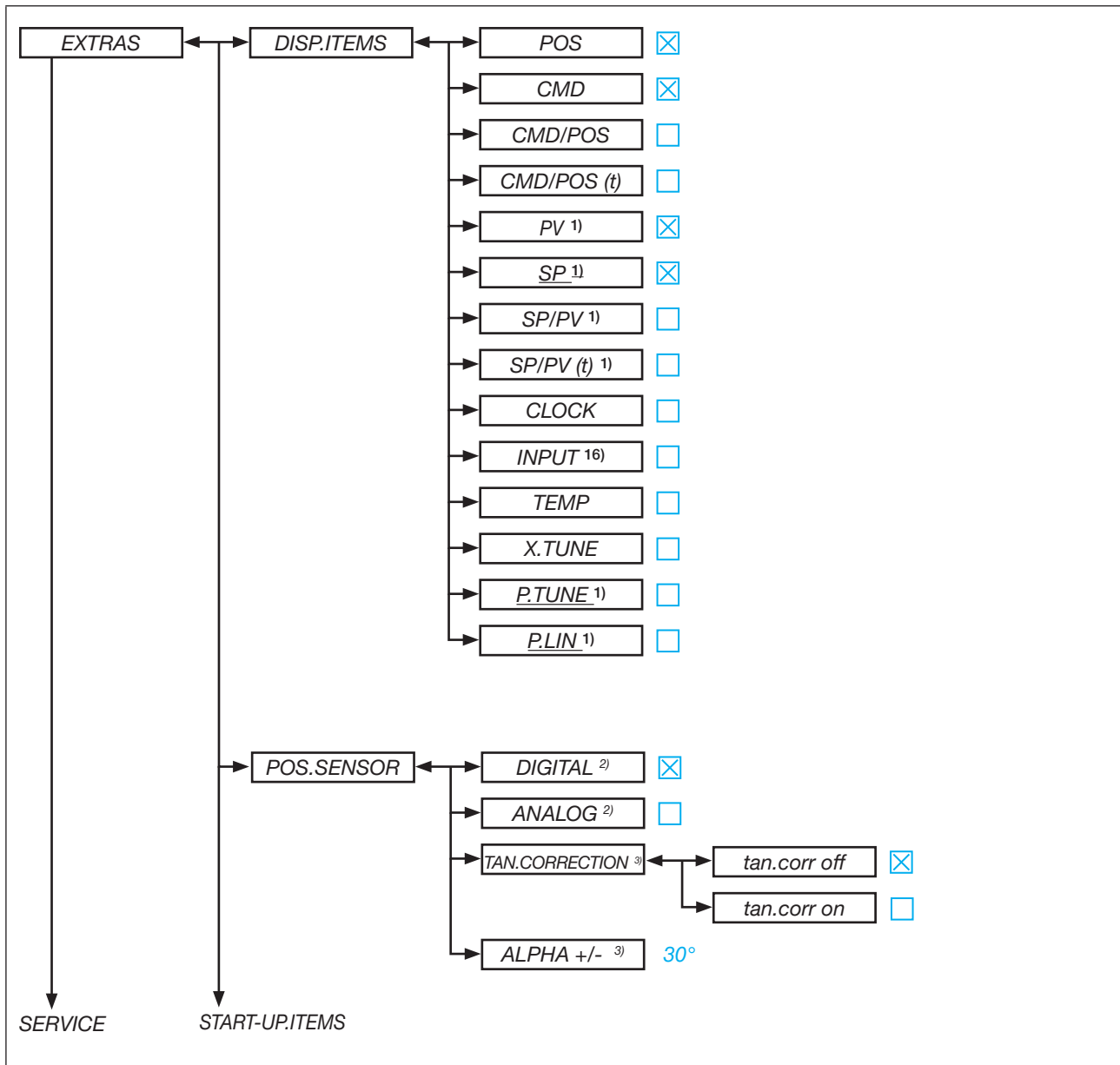


Figure 59: Operating structure - 10

- 1) Only process controller Type 8793
- 2) Only Type 8793 Remote
- 3) All devices other than Remote
- 16) Not for fieldbus

MAN 1000341264 EN Version: C Status: RL (released | freigegeben) printed: 09.12.2019

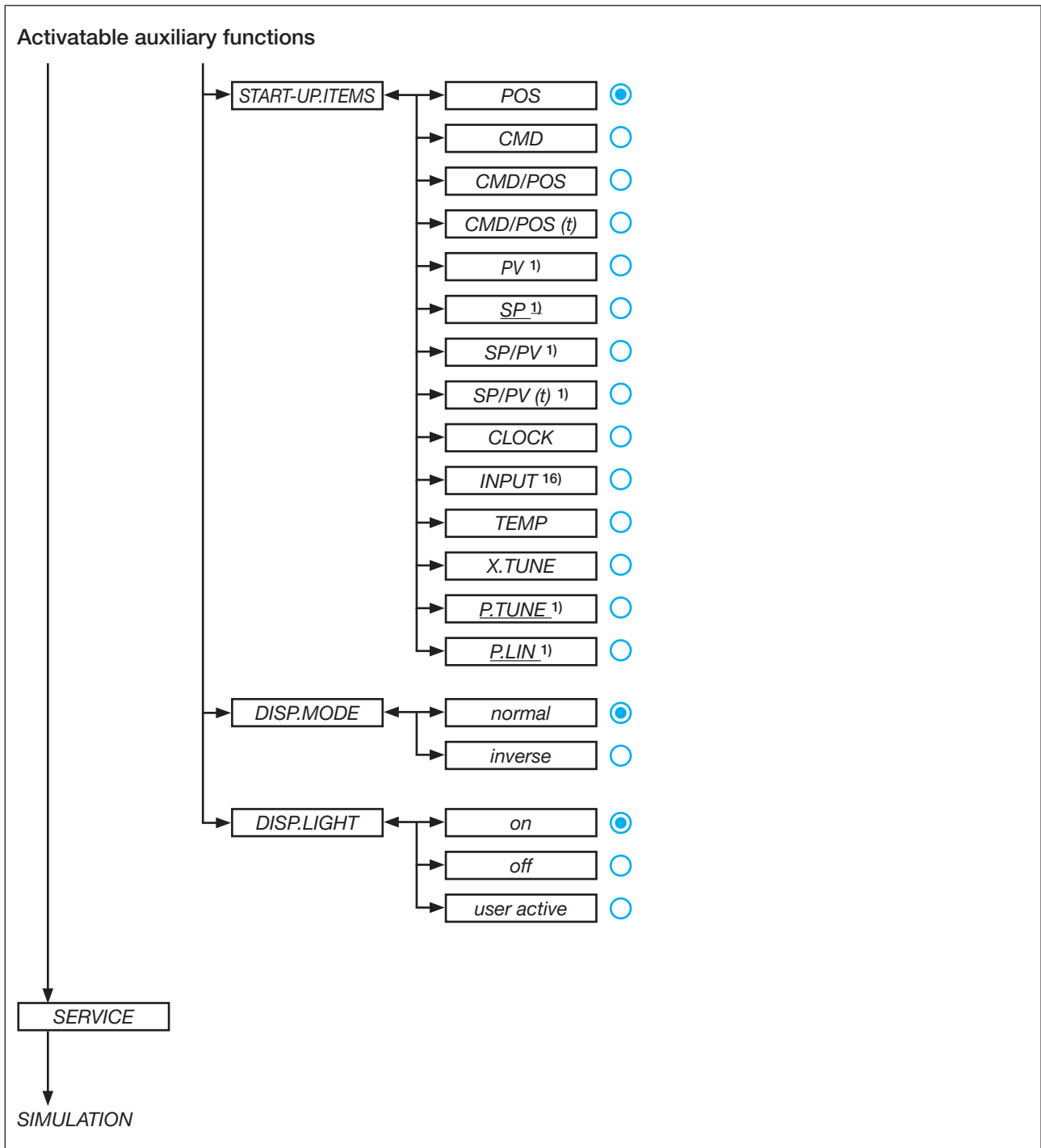


Figure 60: Operating structure - 11

1) Only process controller Type 8793

16) Not for fieldbus

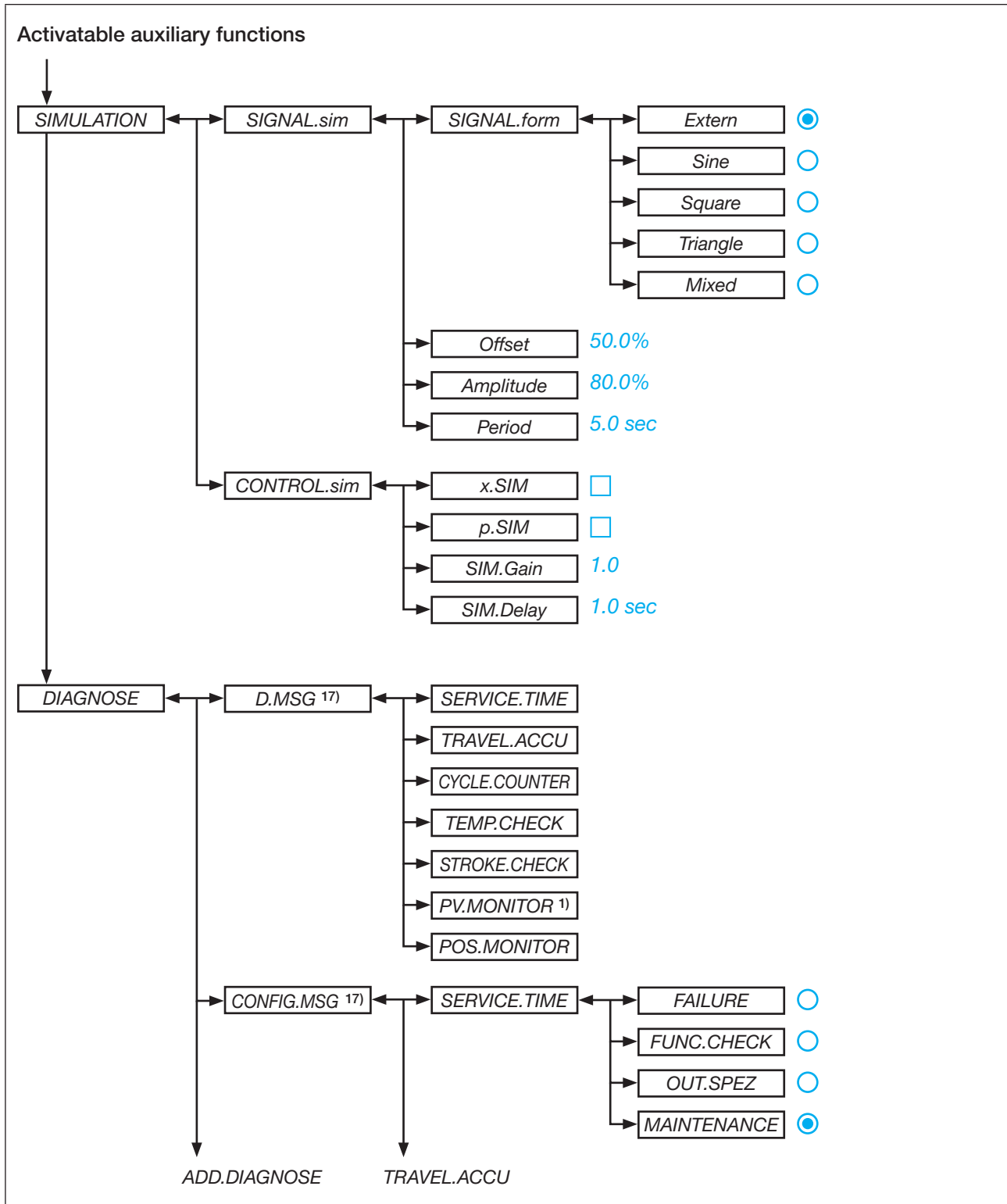


Figure 61: Operating structure - 12

1) Only process controller Type 8793

17) The submenu lists only the activated diagnostic functions

MAN 1000341264 EN Version: C Status: RL (released | freigegeben) printed: 09.12.2019

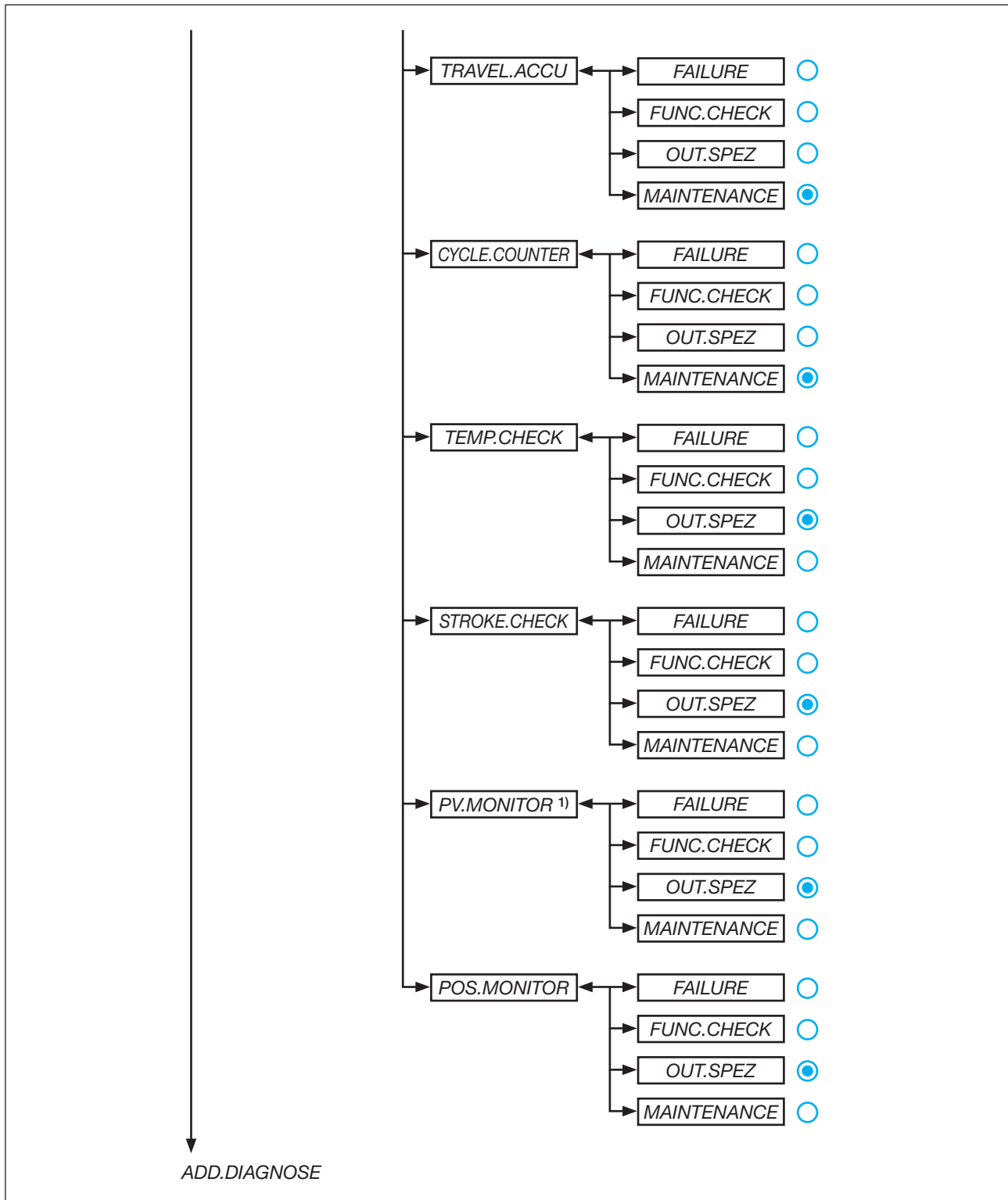


Figure 62: Operating structure - 13

1) Only process controller Type 8793

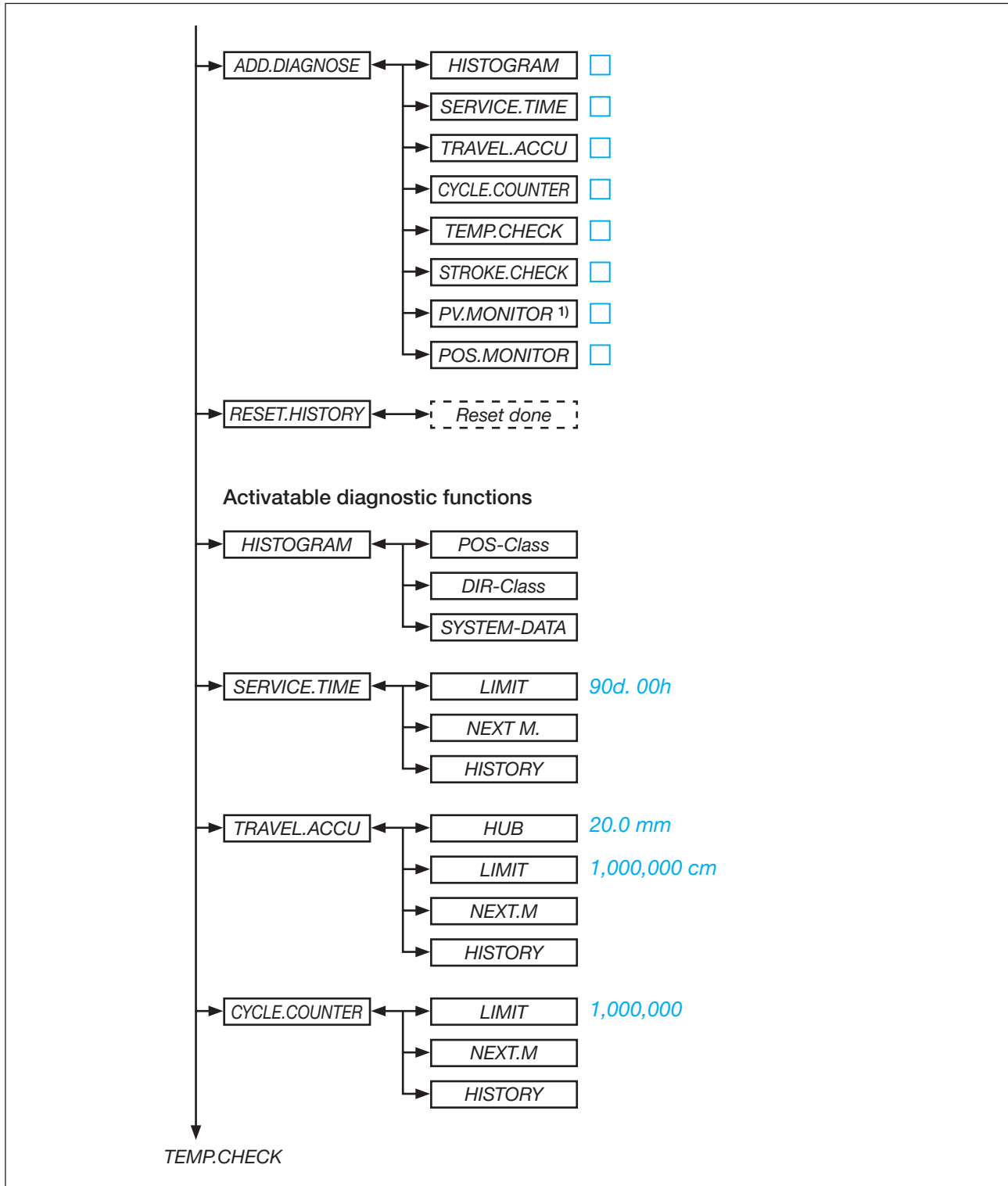


Figure 63: Operating structure - 14

MAN 1000341264 EN Version: C Status: RL (released | freigegeben) printed: 09.12.2019



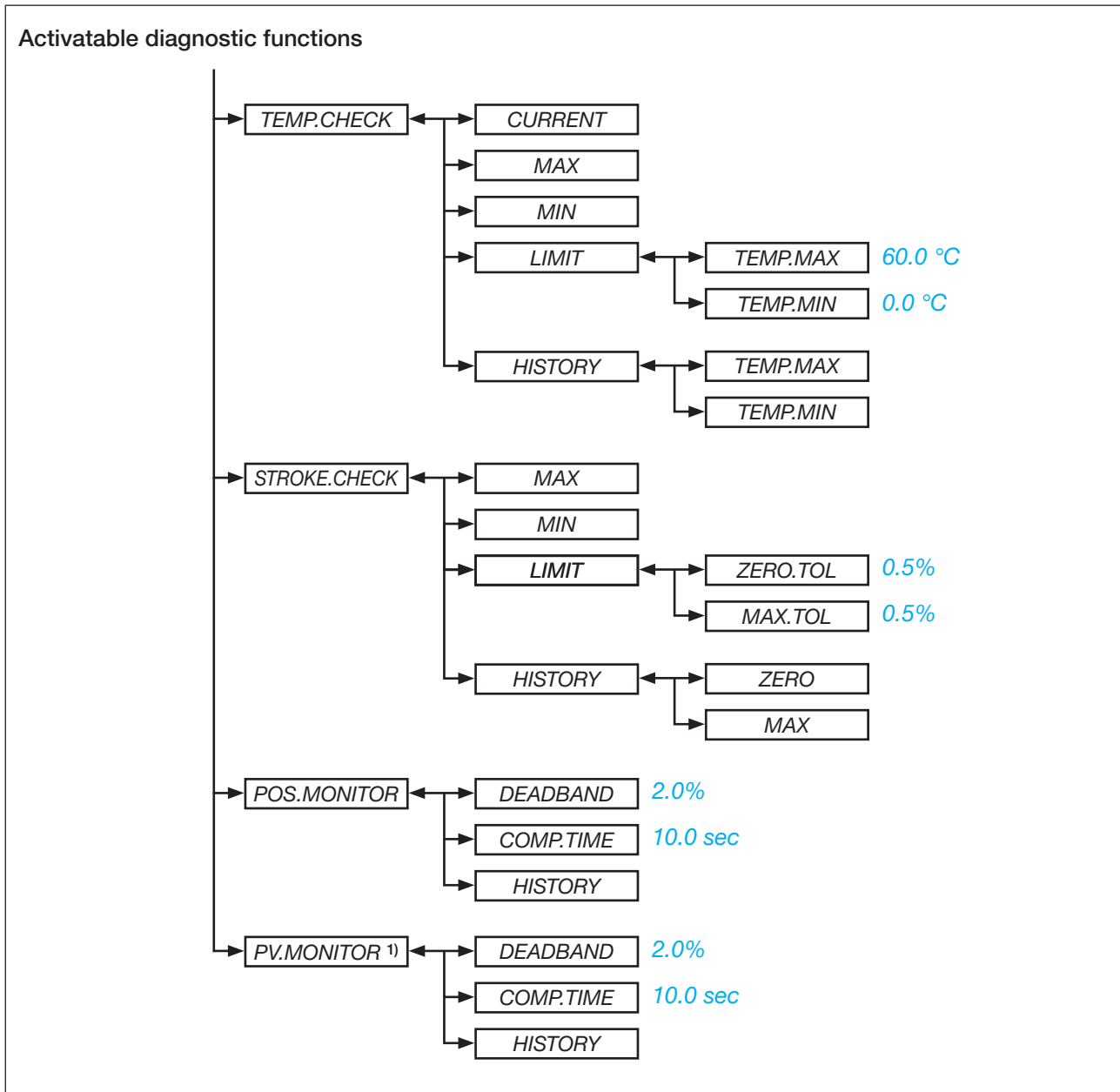


Figure 64: Operating structure - 15

MAN 1000341264 EN Version: C Status: RL (released | freigegeben) printed: 09.12.2019

1) Only process controller Type 8793

# 19 ETHERNET/IP, PROFINET AND MODBUS TCP

## 19.1 Technical data



### DANGER

Risk of injury due to electric shock.

- ▶ Before reaching into the system, switch off the power supply and secure to prevent reactivation.
- ▶ Observe the applicable accident prevention regulations and safety regulations for electrical equipment.



### WARNING

Risk of injury from improper installation.

- ▶ Installation may be carried out by authorized technicians only and with the appropriate tools.

Risk of injury due to unintentional switching on of the plant and uncontrolled start-up.

- ▶ Secure the device against accidental activation.
- ▶ Following installation, ensure a controlled restart.

Network speed	10/100 mbps
Auto negotiation	Yes
Switch function	Yes
Network diagnostics	Yes, via error telegram
MAC-ID	Individual identification number, stored in the module and on the outside of the device (see type label)
Device name Ethernet (factory settings)	Positioner / process controller (name can be changed)

## 19.2 Industrial Ethernet

### PROFINET IO specifications

Topology recognition	LLDP, SNMP V1, MIB2, physical device
Minimum cycle time	10 ms
IRT	Not supported
MRP media redundancy	MRP client is supported
Further supported functions	DCP, VLAN priority tagging, shared device
Transfer rate	100 mbit/s
Data transport network	Ethernet II, IEEE 802.3
PROFINET IO specification	V2.3
(AR) Application Relations	The device can simultaneously process up to 2 IO ARs, 1 Supervisor AR, and 1 Supervisor DA AR.

**EtherNet/IP specifications**

Predefined standard objects	Identity Object (0x01) Message Router Object (0x02) Assembly Object (0x04) Connection Manager (0x06) DLR Object (0x47) QoS Object (0x48) TCP/IP Interface Object (0xF5) Ethernet Link Object (0xF6)
DHCP	Supported
BOOTP	Supported
Transfer rate	10 and 100 mbit/s
Duplex modes	Half duplex, full duplex, auto negotiation
MDI modes	MDI, MDI-X, Auto-MDIX
Data transport network	Ethernet II, IEEE 802.3
Address Conflict Detection (ACD)	Supported
DLR (ring topology)	Supported
CIP reset service	Identity object reset service Types 0 and 1

**Modbus TCP specifications**

Modbus function codes	1, 2, 3, 4, 6, 15, 16, 23
Operation mode	Message mode: Server
Transfer rate	10 and 100 mbit/s
Data transport network	Ethernet II, IEEE 802.3

### 19.2.1 Connection diagram Type 8792

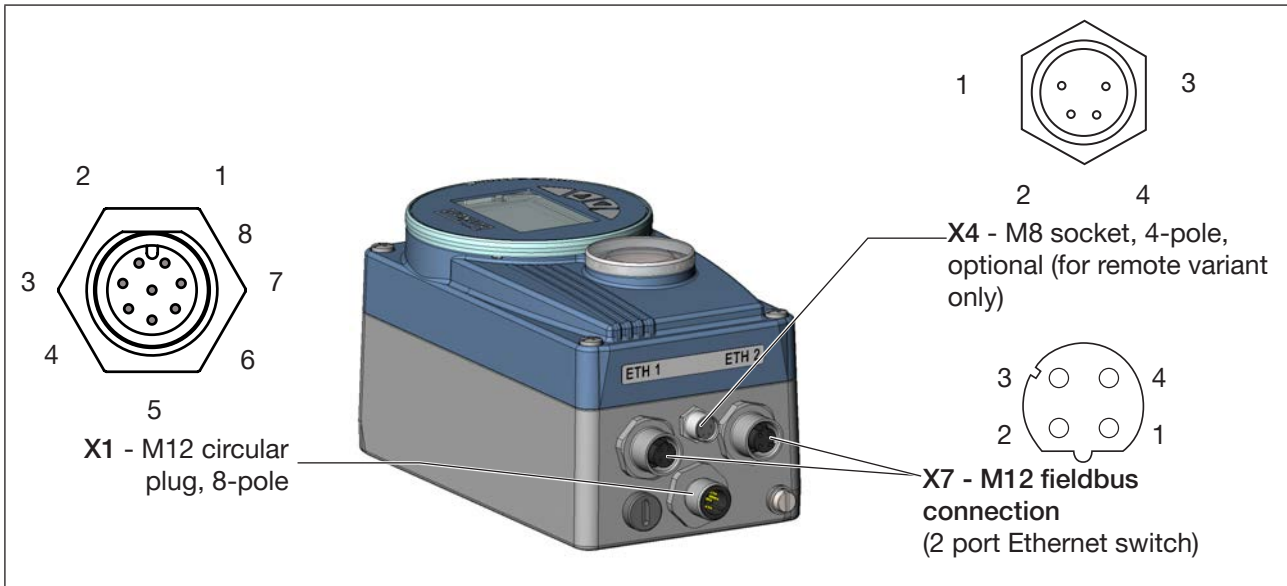


Figure 65: Fieldbus connection, positioner Type 8792

### 19.2.2 Connection diagram Type 8793

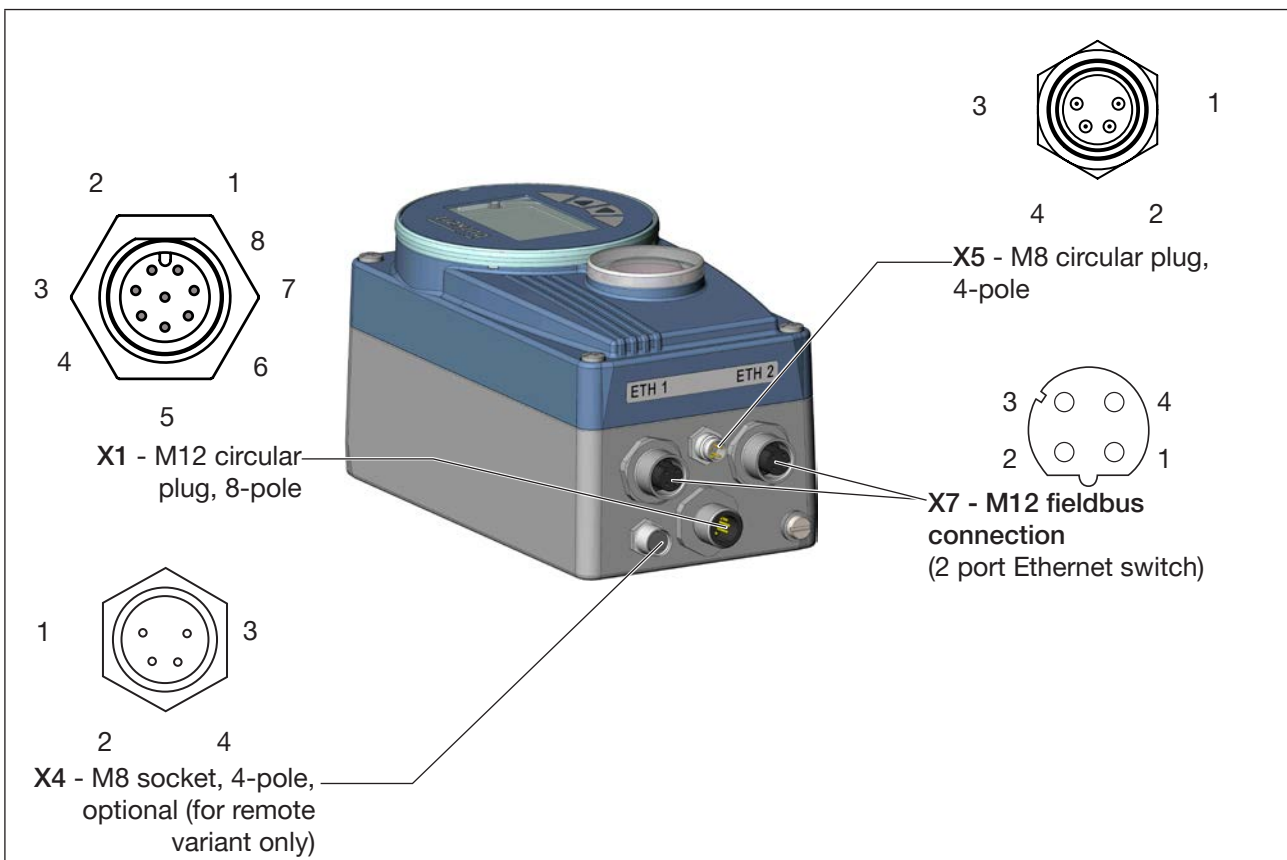


Figure 66: Fieldbus connection, process controller Type 8793

MAN 1000341264 EN Version: C Status: RL (released | freigegeben) printed: 09.12.2019

### 19.3 X7 - M12 fieldbus connection D-coded

The EtherNet/IP is connected with an M12 circular plug-in connector, 4-pole D-coded.

	Pin 1	Transmit +
	Pin 2	Receive +
	Pin 3	Transmit -
	Pin 4	Receive -

Table 54: Electrical assignment EtherNet

### 19.4 X1 - M12 circular plug, 8-pole

Pin	Assignment	On the device side	External circuit / signal level
1	Not assigned		
2	Not assigned		
Operating voltage			
3	GND		24 V DC ± 10% max. residual ripple 10%
4	+ 24 V		
Input signal of the control center (e.g. PLC)			
5	Binary input +		0...5 V (log.0) 10...30 V (log.1)
6	Binary input -		
Output signals to the control center (e.g. PLC) - (assigned for the binary output option only)			
7	Binary output 1 (referring to Pin 3)	7	0...24 V
8	Binary output 2 (referring to Pin 3)	8	0...24 V

Table 55: X1 - M12 circular plug, 8-pole (operating voltage)

### 19.5 X4 - M8 socket, 4-pole, optional - Remote sensor (for remote variant only)

Connection of the digital, non-contacting position sensor Type 8798:

Pin	Assignment	On the device side	External circuit
1	Supply sensor +	S +	
2	Supply sensor -	S -	
3	Serial interface, A cable	A	
4	Serial interface, B cable	B	

Table 56: Pin assignment; X4 - M8 socket, 4-pole - digital, non-contacting position sensor Type 8798

MAN 1000341264 EN Version: C Status: RL (released | freigegeben) printed: 09.12.2019

**Connection of an analog, potentiometric position sensor:**

Pin	Assignment	On the device side	External circuit
1	Potentiometer 1	1	
2	Sliding contact 2	2	
3	Potentiometer 3	3	
4	Not assigned		

Table 57: Pin assignment; X4 - M8 socket - 4-pole - analog, potentiometer-type position sensor

**19.6 X5 - M8 circular plug, 4-pole - Process actual value (for Type 8793)**

Input type*	Pin	Wire color **	Assignment	DIP switches***	On the device side	External circuit
4...20 mA - internally supplied	1	brown	+24 V transmitter power supply	 Switch on left		
	2	white	Output from transmitter			
	3	blue	GND (identical to GND operating voltage)			
	4	black	Bridge after GND (Pin 3)			
4...20 mA - externally supplied	1	brown	Not assigned	 Switch on right		
	2	white	Process actual +			
	3	blue	Not assigned			
	4	black	Process actual -			
Frequency - internally supplied	1	brown	+24 V sensor power supply	 Switch on left		
	2	white	Clock input +			
	3	blue	Clock input - (GND)			
	4	black	Not assigned			
Frequency - externally supplied	1	brown	Not assigned	 Switch on right		
	2	white	Clock input +			
	3	blue	Clock input -			
	4	black	Not assigned			
Pt 100 (see information below)	1	brown	Not assigned	 Switch on right		
	2	white	Process actual 1 (power supply)			
	3	blue	Process actual 3 (GND)			
	4	black	Process actual 2 (compensation)			

\* Can be adjusted via software (see chapter "14.3 INPUT - Setting the input signal")

\*\* The indicated wire colors refer to the connection cable available as an accessory (918 718).

\*\*\* The switch is located inside the device on the printed circuit board (see "Figure 25: Location of the switch; symbols for switch position")

Table 58: Pin assignment; X5 - M8 circular plug, 4-pole - process actual value input

MAN 1000341264 EN Version: C Status: RL (released | freigegeben) printed: 09.12.2019

**NOTE**

To ensure electromagnetic compatibility (EMC), use a shielded Ethernet cable. Ground the cable shield on both sides, on each of the connected devices.  
 For the grounding use a short line (max. 1 m) with a cross-section of at least 1.5 mm<sup>2</sup>.

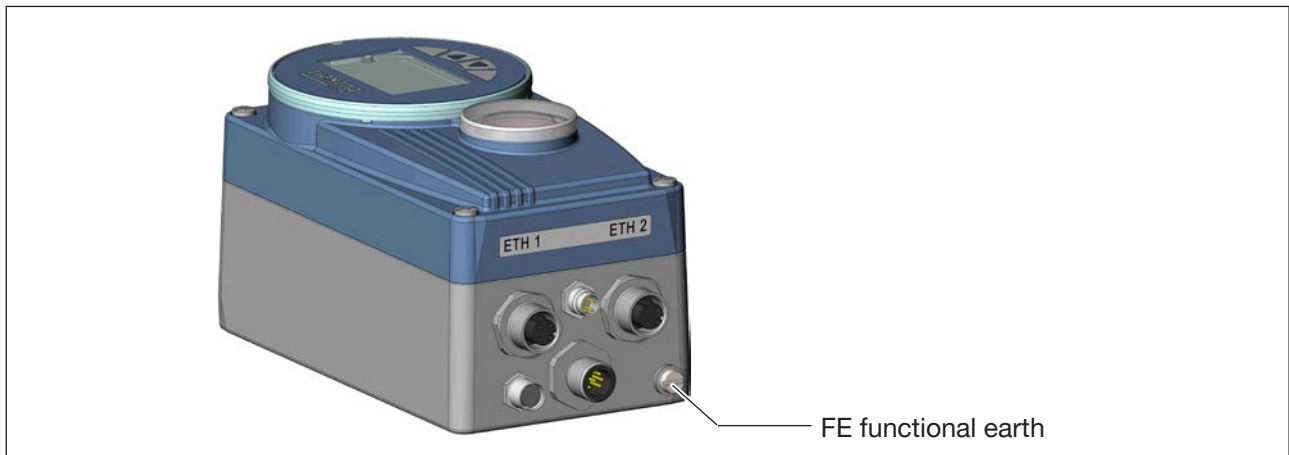


Figure 67: Functional earth

## 19.7 Bus status display

The bus status is indicated on the display on the device.

Display (is displayed approx. every 3 seconds)	Device state	Explanation	Troubleshooting
<i>BUS no connection</i>	Online, no connection to the master.	Device is connected correctly to the bus, the network access procedure has ended without errors, however there is no established connection to the master.	<ul style="list-style-type: none"> <li>• New connection established by master.</li> </ul>
<i>BUS critical err</i>	Critical bus error.	Other device with the same address in the network. <i>BUS offline</i> due to communication problems.	<ul style="list-style-type: none"> <li>• Change address of the device and restart device.</li> <li>• Fault analysis in the network with a bus monitor.</li> </ul>

Table 59: Bus status display; Ethernet

## 19.7.1 Differences between the fieldbus devices and devices without a fieldbus

The following chapters of these operating instructions are not valid for Type 8792, 8793 with EtherNet.

- Section “Installation” chapter [“12 Electrical installation”](#)
- Section “Start-up” chapter [“14.3 INPUT - Setting the input signal”](#)
- Section “Auxiliary functions” chapter [“16.1.7 SPLTRNG – Signal split range”](#)  
chapter [“16.1.17 CAL.USER – Calibration of actual value and set-point value”](#)
  - menu option *calibr.INP*, calibration des set-point position
  - menu option *calibr.SP*, calibration of the process set-point
- chapter [“16.1.15 BINARY.IN – Activation of the binary input”](#)
- chapter [“16.1.16 OUTPUT – Configuration of the outputs \(option\)”](#)

## 19.7.2 BUS.COMM – Settings on Type 8792, 8793

Set the following menu options in the *BUS.COMM* menu for start-up of the EtherNet variant:

- BUS FAIL** Activate or deactivate approach of the safety position
- Selection  **SafePos off**  – The actuator remains in the position which corresponds to the set-point value last transferred (default setting).
- Selection  **SafePos on**  – If there is a fault in the bus communication, the behavior of the actuator depends on the activation of the *SAFEPOS* auxiliary function. See chapter [“16.1.13 SAFEPOS – Inputting the safety position”](#).
- SAFEPOS* activated: The actuator moves to the safety position which is specified in the *SAFEPOS* auxiliary function.
- SAFEPOS* deactivated: The actuator moves to the safety end position which it would assume if the electrical and pneumatic auxiliary power failed. See chapter [“10.9 Safety end positions after failure of the electrical or pneumatic auxiliary power”](#)

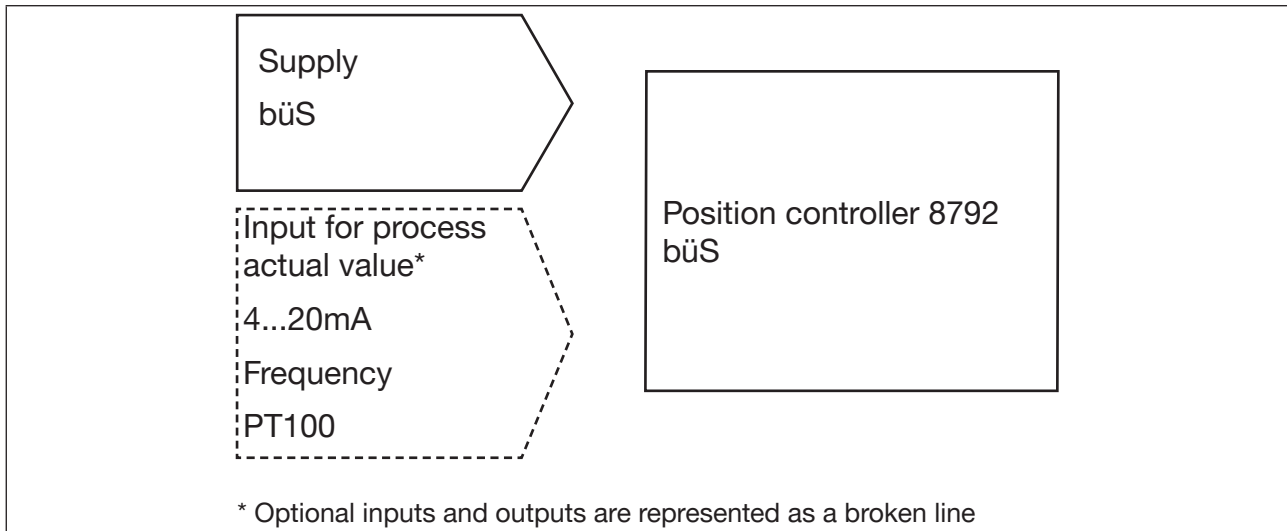


## 20 BÜS OPTION

### 20.1 Definition

bÜS is a fieldbus which is based on CANopen with additional functionality for networking several devices.

### 20.2 Interfaces



### 20.3 Electrical installation - bÜS

#### 20.3.1 Safety instructions



#### **DANGER**

Risk of injury due to electric shock.

- ▶ Before reaching into the system, switch off the power supply and secure to prevent reactivation.
- ▶ Observe the applicable accident prevention regulations and safety regulations for electrical equipment.



#### **WARNING**

Risk of injury from improper installation.

- ▶ Installation may be carried out by authorized technicians only and with the appropriate tools.

Risk of injury due to unintentional switching on of the plant and uncontrolled start-up.

- ▶ Secure the device against accidental activation.
- ▶ Following installation, ensure a controlled restart.

20.3.1.1. Connection diagram Type 8792

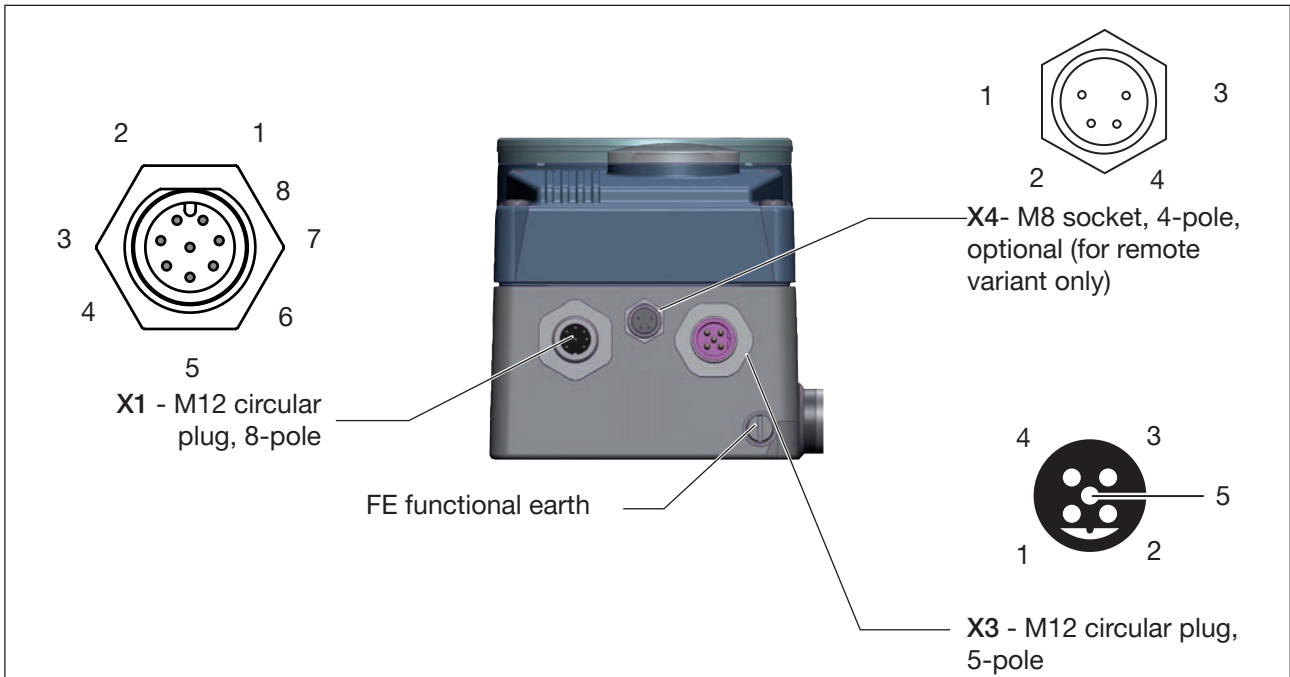


Figure 68: Connection diagram Type 8792

20.3.1.2. Connection diagram Type 8793

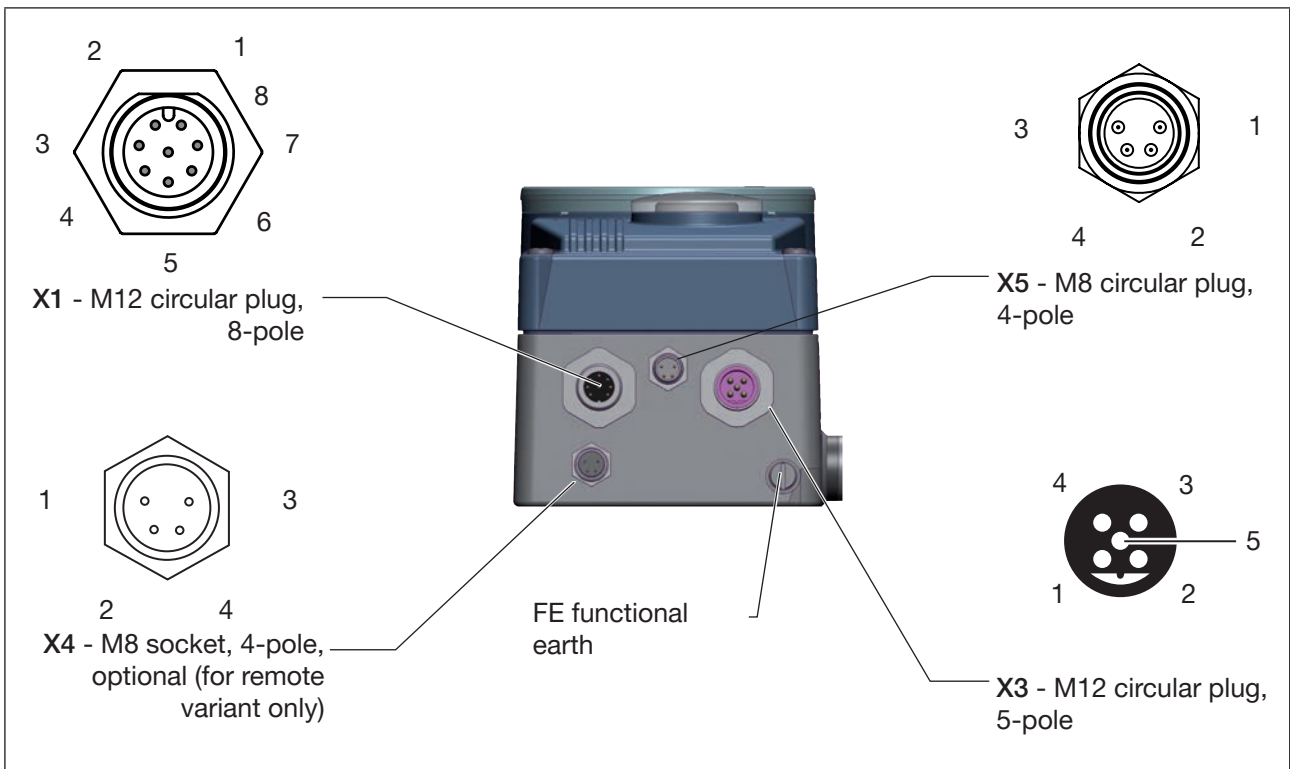


Figure 69: Connection diagram Type 8793

MAN 1000341264 EN Version: C Status: RL (released | freigegeben) printed: 09.12.2019

## 20.4 X1 - M12 circular plug, 8-pole

Pin	Assignment	On the device side	External circuit / signal level
1	Not assigned		
2	Not assigned		
Operating voltage			
3	GND		24 V DC ± 10% max. residual ripple 10%
4	+ 24 V		
Input signal of the control center (e.g. PLC)			
5	Binary input +		0...5 V (log.0) 10...30 V (log.1)
6	Binary input -		
Output signals to the control center (e.g. PLC) - (assigned for the binary output option only)			
7	Binary output 1 (referring to Pin 3)	7	0...24 V
8	Binary output 2 (referring to Pin 3)	8	0...24 V

Table 60: X1 - M12 circular plug, 8-pole (operating voltage)

### 20.4.1 X3 - circular plug-in connector M12x1, 5-pole

X3 - circular plug-in connector M12x1, 5-pole, male:

Pin	Wire color	Assignment
1	CAN shield	CAN shield
2	Not assigned	
3	Black	Black GND / CAN_GND
4	White	White CAN_H
5	Blue	Blue CAN_L

Table 61: Connection of the circular plug-in connector



**Electrical installation with or without büS network:**

To be able to use the büS network (CAN interface), a 5-pole circular plug and a shielded 5-wire cable must be used.

## 20.5 X4 - M8 socket, 4-pole, optional - Remote sensor (for remote variant only)

Connection of the digital, non-contacting position sensor Type 8798:

Pin	Assignment	On the device side	External circuit
1	Supply sensor +	S +	
2	Supply sensor -	S -	
3	Serial interface, A cable	A	
4	Serial interface, B cable	B	

Table 62: Pin assignment; X4 - M8 socket, 4-pole - digital, non-contacting position sensor Type 8798





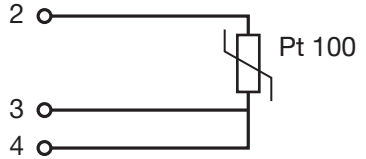
Connection of an analog, potentiometric position sensor:

Pin	Assignment	On the device side	External circuit
1	Potentiometer 1	1	
2	Sliding contact 2	2	
3	Potentiometer 3	3	
4	Not assigned		

Table 63: Pin assignment; X4 - M8 socket - 4-pole - analog, potentiometer-type position sensor

## 20.6 X5 - M8 circular plug, 4-pole - Process actual value (for Type 8793)

Input type*	Pin	Wire color **	Assignment	DIP switches***	On the device side	External circuit
4...20 mA - internally supplied	1	brown	+24 V transmitter power supply			Transmitter GND
	2	white	Output from transmitter			
	3	blue	GND (identical to GND operating voltage)			
	4	black	Bridge after GND (Pin 3)			
4...20 mA - externally supplied	1	brown	Not assigned			4...20 mA GND 4...20 mA
	2	white	Process actual +			
	3	blue	Not assigned			
	4	black	Process actual -			
Frequency - internally supplied	1	brown	+24 V sensor power supply			+24 V Clock + Clock - GND (identical to GND operating voltage)
	2	white	Clock input +			
	3	blue	Clock input - (GND)			
	4	black	Not assigned			

Input type*	Pin	Wire color **	Assignment	DIP switches***	On the device side	External circuit
Frequency - externally supplied	1	brown	Not assigned	 Switch on right	2  Clock + 3  Clock -	
	2	white	Clock input +			
	3	blue	Clock input -			
	4	black	Not assigned			
Pt 100 (see information below)	1	brown	Not assigned	 Switch on right		
	2	white	Process actual 1 (power supply)			
	3	blue	Process actual 3 (GND)			
	4	black	Process actual 2 (compensation)			

\* Can be adjusted via software (see chapter "14.3 INPUT - Setting the input signal")

\*\* The indicated wire colors refer to the connection cable available as an accessory (918 718).

\*\*\* The switch is located inside the device on the printed circuit board (see "Figure 25: Location of the switch; symbols for switch position")

Table 64: Pin assignment; X5 - M8 circular plug, 4-pole - process actual value input

## 20.7 BUS.COMM – Settings on Type 8792, 8793

Set the following menu options in the *BUS.COMM* menu for start-up of the EtherNet variant:

**BUS FAIL** Activate or deactivate approach of the safety position

Selection **SafePos off**  – The actuator remains in the position which corresponds to the set-point value last transferred (default setting).

Selection **SafePos on**  – If there is a fault in the bus communication, the behavior of the actuator depends on the activation of the *SAFEPOS* auxiliary function. See chapter "16.1.13 *SAFEPOS* – Inputting the safety position".

*SAFEPOS* activated: The actuator moves to the safety position which is specified in the *SAFEPOS* auxiliary function.

*SAFEPOS* deactivated: The actuator moves to the safety end position which it would assume if the electrical and pneumatic auxiliary power failed. See chapter "10.9 Safety end positions after failure of the electrical or pneumatic auxiliary power"

**BUS.COMM** is set as follows:

→  Press **MENU** for 3 s. Switching from process level ⇌ setting level.




▲ / ▼ Select **BUS.COMM**. Selection in the main menu (MAIN).

→  Select **ENTER**. The submenu options for basic settings can now be selected.







Setting device address:

(for büS devices the address is automatically set)

→ ▲ / ▼ Select address.

-  Select **INPUT**. The input screen is opened.
-  **+** Increase value or **-** reduce value. Enter a device address (value between 0 and 127).
-  Select **OK**. Return to *BUS.COMM*.

**Select baud rate:**

-  Select *BAUD RATE*.
-  Select **ENTER**. The input screen is opened.
-  Select *BAUD RATE. 50 kBd / 125 kBd / 250 kBd / 500 kBd / 1000 kBd*
-  Select **SELECT**. The selection is now marked by a filled circle .
-  Select **EXIT**. Return to *BUS.COMM*.

 You have set *BUS.COMM*.



With büS devices not only the büS service interface but also the Bürkert-Communicator can be connected directly to the büS network.

## 21 MAINTENANCE AND TROUBLESHOOTING

### 21.1 Safety instruction



#### WARNING

Risk of injury due to incorrect maintenance work.

- ▶ Maintenance may be carried out only by trained technicians and with the appropriate tools.
- ▶ Secure the device against accidental activation.
- ▶ Ensure controlled start-up after maintenance.

### 21.2 Maintenance

If these instructions are followed for operation, Type 8792/8793 is maintenance-free.

### 21.3 Error messages

Display	Causes of error	Remedy
	Minimum input value has been reached.	Do not reduce value further.
	Maximum input value has been reached.	Do not increase value further.
<i>CMD error</i>	Signal fault Set-point value positioner (position controller).	Check signal.
<i>SP error</i>	Signal fault Set-point value process controller.	Check signal.
<i>PV error</i>	Signal fault Actual value process controller.	Check signal.
<i>PT100 error</i>	Signal fault Actual value Pt 100.	Check signal.
<i>invalid code</i>	Incorrect access code.	Enter correct access code.
<i>EEPROM fault</i>	EEPROM defective.	Not possible, device defective.

Table 65: General error messages

### 21.3.1 Error and warning messages while the X.TUNE function is running

Display	Causes of error	Remedy
<i>TUNE</i> <i>err/break</i>	Manual termination of self-optimization by pressing the <b>EXIT</b> key.	
<i>X.TUNE</i> locked	The <i>X.TUNE</i> function is blocked.	Enter access code.
<i>X.TUNE</i> <i>ERROR 1</i>	No compressed air connected.	Connect compressed air.
<i>X.TUNE</i> <i>ERROR 2</i>	Compressed air failure while Autotune ( <i>X.TUNE</i> ) is running.	Check compressed air supply.
<i>X.TUNE</i> <i>ERROR 3</i>	Actuator or control system deaeration side leaking.	Not possible, device defective.
<i>X.TUNE</i> <i>ERROR 4</i>	Control system aeration side leaking.	Not possible, device defective.
<i>X.TUNE</i> <i>ERROR 5</i>	The rotation range of the position sensor has exceeded 180°.	Correct attachment of the position sensor shaft to the actuator (see <i>chapter "12.2" and "12.3"</i> ).
<i>X.TUNE</i> <i>ERROR 6</i>	The end positions for <i>POS-MIN</i> and <i>POS-MAX</i> are too close together.	Check compressed air supply.
<i>X.TUNE</i> <i>ERROR 7</i>	Incorrect assignment <i>POS-MIN</i> and <i>POS-MAX</i> .	To determine <i>POS-MIN</i> and <i>POS-MAX</i> , move the actuator in the direction indicated on the display.
<i>X.TUNE</i> <i>WARNING 1**</i>	Potentiometer is not coupled optimally to the actuator.  An optimum connection can provide a more accurate position measurement.	Set the center position as described in <i>chapter "12.2.4. Aligning lever mechanism"</i> .

\*\* Warning information gives tips for optimized operation. The device is operational even if this warning information is not observed. Warning information is automatically hidden after several seconds.

Table 66: Error and warning message on X.TUNE



### 21.3.2 Error messages while running the P.Q'LIN function

Display	Causes of error	Remedy
TUNE err/break	Manual termination of self-optimization by pressing the <b>EXIT</b> key.	
P.Q LIN ERROR 1	No compressed air connected.  No change to process variable.	Connect compressed air.  Check process and, if required, switch on pump or open the shut-off valve. Check process sensor.
P.Q LIN ERROR 2	Current node of the valve stroke was not reached, as <ul style="list-style-type: none"> <li>• Compressed air failure during P.Q'LIN.</li> <li>• Autotune (X.TUNE) was not run.</li> </ul>	Check compressed air supply.  Run Autotune (X.TUNE).

Table 67: Error message for P.Q'LIN; process controller Type 8793

### 21.3.3 Error messages while the P.TUNE function is running

Display	Causes of error	Remedy
TUNE err/break	Manual termination of self-optimization by pressing the <b>EXIT</b> key.	
P.TUNE ERROR 1	No compressed air connected.  No change to process variable.	Connect compressed air.  Check process and, if required, switch on pump or open the shut-off valve. Check process sensor.

Table 68: Error message for P.TUNE; process controller Type 8793

For Ethernet/IP, PROFINET, Modbus TCP

Display (is displayed approx. every 3 seconds)	Device state	Explanation	Troubleshooting
<i>BUS no connection</i>	Online, no connection to the master.	Device is connected correctly to the bus, the network access procedure has ended without errors, however there is no established connection to the master.	<ul style="list-style-type: none"> <li>• New connection established by master.</li> </ul>
<i>BUS critical err</i>	Critical bus error.	Other device with the same address in the network.  <i>BUS offline</i> due to communication problems.	<ul style="list-style-type: none"> <li>• Change address of the device and restart device.</li> <li>• Fault analysis in the network with a bus monitor.</li> </ul>

Table 69: Error message Ethernet/IP, PROFINET, Modbus TCP

For BUES device

Display (is displayed approx. every 3 seconds)	Device state	Explanation	Troubleshooting
<i>BUS no connection</i>	Online, no connection to the master.	Device is connected correctly to the bus, the network access procedure has ended without errors, however there is no established connection to the master.	<ul style="list-style-type: none"> <li>• New connection established by master.</li> </ul>
<i>BUS critical err</i>	Critical bus error.	Other device with the same address in the network.  <i>BUS offline</i> due to communication problems.	<ul style="list-style-type: none"> <li>• Change address of the device and restart device.</li> <li>• Fault analysis in the network with a bus monitor.</li> </ul>
<i>Partner not found</i>	Partner not found	A configured partner (Producer) cannot be found.	<ul style="list-style-type: none"> <li>• Check that the configured partner is switched on and connected to the bus network.</li> <li>• Check the bus mapping using the Communicator.</li> </ul>

Table 70: Error message BUES device

## 21.4 Malfunctions

Problem	Possible causes	Remedy
<p><math>POS = 0</math> (when <math>CMD &gt; 0\%</math>) or  <math>POS = 100\%</math>, (when <math>CMD &lt; 100\%</math>).</p> <p><math>PV = 0</math> (when <math>SP &gt; 0</math>) or  <math>PV = PV</math> (when <math>SP &gt; SP</math> ).</p>	Sealing function ( <i>CUTOFF</i> ) is unintentionally activated.	Deactivate sealing function.
<p><b>Applies only to devices with binary output:</b></p> <p>Binary output does not switch.</p>	<p>Binary output:</p> <ul style="list-style-type: none"> <li>• Current &gt; 100 mA</li> <li>• Short circuit</li> </ul>	Check binary output connection.
<p><b>Applies only to devices with process controller:</b></p> <p>Device is not operating as a controller, despite correctly implemented settings.</p>	<i>P.CONTROL</i> menu option is in the main menu. The device is therefore operating as a process controller and expects a process actual value at the corresponding input.	Remove <i>P.CONTROL</i> menu option from the main menu. See chapter <a href="#">“19.1.2. Deactivating auxiliary functions”</a> on page 228.

Table 71: Other malfunctions

## 22 ACCESSORIES

Accessories	Order number
Connection cable with M12 socket, 8-pole, (length 5 m)	919267
Connection cable with M12 socket, 4-pole, (length 5 m)	918038
Connection cable with M8 socket , 4-pole, (length 5 m)	92903474
Connection cable with M12 circular plug, 4-pole, (length 5 m) D-coded	On request
USB bÜS interface set:	
bÜS service interface (bÜS stick + +0.7 m cable with M12 plug)	772551
bÜS adapter for bÜS service interface (M12 to bÜS service interface micro USB)	773254
bÜS cable extensions from M12 plug to M12 socket	
Connection cable, length 1 m	772404
Connection cable, length 3 m	772405
Connection cable, length 5 m	772406
Connection cable, length 10 m	772407
Bürkert-Communicator	Information at <a href="http://www.buerkert.de">www.buerkert.de</a>

Table 72: Accessories

### 22.1 Communication software

The PC operating program “Bürkert-Communicator” is designed for communication with Bürkert devices.



A detailed description for installing and operating the software can be found in the associated operating instructions.

### 22.2 Download

Download the software from: [www.buerkert.de](http://www.buerkert.de)

### 22.3 USB interface

The PC requires a USB interface for communication with the devices, also a USB-bÜS interface set (see “Table 72: Accessories”).

Data is transmitted according to CANopen specification.

## 23 PACKAGING, TRANSPORT

### NOTE

Transport damage.

Inadequately protected devices may be damaged during transportation.

- Protect the device against moisture and dirt in shock-resistant packaging during transportation.
- Prevent the temperature from exceeding or dropping below the permitted storage temperature.

## 24 STORAGE

### NOTE

Incorrect storage may damage the device.

- Store the device in a dry and dust-free location.
- Storage temperature. -20 to +65 °C.

## 25 DISPOSAL

→ Dispose of the device and packaging in an environmentally friendly manner.

### NOTE

Damage to the environment caused by device components contaminated with media.

- Observe applicable disposal regulations and environmental regulations.



Observe the national waste disposal regulations.

## 26 SUPPLEMENTARY INFORMATION

### 26.1 Selection criteria for continuous valves

The following criteria are crucial for optimum control behavior and to ensure that the required maximum flow is reached:

- the correct selection of the flow coefficient which is defined primarily by the orifice of the valve;
- close coordination between the valve orifice and the pressure conditions in consideration of the remaining flow resistance in the equipment.

Design guidelines can be given on the basis of the flow coefficient ( $k_v$  value). The  $k_v$  value refers to standardized conditions regarding pressure, temperature and media properties.

The  $k_v$  value describes the flow rate of water through a component in  $m^3/h$  at a pressure difference of  $\Delta p = 1$  bar and  $T = 20$  °C.

The “ $k_{vS}$ -value” is additionally used for continuous valves. This indicates the  $k_v$  value when the continuous valve is fully open.

Depending on the specified data, it is necessary to differentiate between the two following cases when selecting the valve:

- a) The pressure values  $p_1$  and  $p_2$ , known before and after the valve, represent the required maximum flow rate  $Q_{max}$  which is to be reached:

The required  $k_{vS}$ -value is calculated as follows:

$$k_{vS} = Q_{max} \cdot \sqrt{\frac{\Delta p_0}{\Delta p}} \cdot \sqrt{\frac{\rho}{\rho_0}} \quad (1)$$

With:

- $k_{vS}$  flow coefficient of the continuous valve at full opening [ $m^3/h$ ]
- $Q_{max}$  max. volumetric flow rate [ $m^3/h$ ]
- $\Delta p_0 = 1$  bar; pressure loss on the valve according to the definition of the  $k_v$  value
- $\rho_0 = 1000$   $kg/m^3$ ; density of water (according to the definition of the  $k_v$  value)
- $\Delta p$  pressure loss on the valve [bar]
- $\rho$  density of the medium [ $kg/m^3$ ]

b) The pressure values, known at the input and output of the entire equipment ( $p_1$  and  $p_2$ ), at which the desired maximum flow rate  $Q_{\max}$  shall be reached:

- 1<sup>st</sup> step: Calculate the flow coefficient of the entire equipment  $k_{v\text{total}}$  according to equation (1).
- 2<sup>nd</sup> step: Determine the flow rate through the equipment without the continuous valve (e.g. by “bypassing” the line at the installation location of the continuous valve).
- 3<sup>rd</sup> step: Calculate the flow coefficient of the equipment without the continuous valve ( $k_{va}$ ) according to equation (1).
- 4<sup>th</sup> step: Calculate the required  $k_{vs}$ -value of the continuous valve according to equation (2):

$$k_{vs} = \sqrt{\frac{1}{\frac{1}{k_{v\text{ges}}^2} - \frac{1}{k_{va}^2}}} \quad (2)$$



The  $k_{vs}$ -value of the continuous valve should have at least the value which is calculated according to equation (1) or (2) which is appropriate to the application, however it should never be far above the calculated value.

The rule of thumb “slightly higher is never harmful” often used for switching valves may greatly impair the control behavior of continuous valves.

The upper limit for the  $k_{vs}$ -value of the continuous valve can be specified in practice via the so-called valve authority  $\Psi$ :

$$\Psi = \frac{(\Delta p)_{vo}}{(\Delta p)_o} = \frac{k_{va}^2}{k_{va}^2 + k_{vs}^2} \quad (3)$$

$(\Delta p)_{vo}$  Pressure drop over the fully opened valve

$(\Delta p)_o$  Pressure drop over the entire equipment



If the valve authority  $\Psi < 0.3$  the continuous valve has been oversized.

When the continuous valve is fully open, the flow resistance in this case is significantly less than the flow resistance of the remaining fluid components in the equipment. This means that the valve position predominates in the operating characteristic in the lower opening range only. For this reason the operating characteristic is highly deformed.

By selecting a progressive (equal percentage) transfer characteristic between position set-point value and valve stroke, this can be partially compensated and the operating characteristic linearized within certain limits. However, the valve authority  $\Psi$  should be  $> 0.1$  even if a correction characteristic is used.

The control behavior (control quality, transient time) depends greatly on the operating point if a correction characteristic is used.

## 26.2 Properties of PID controllers

A PID controller has a proportional, an integral and a differential portion (P, I and D portion).

### 26.2.1 P portion

Function:

$$Y = K_p \cdot X_d$$

$K_p$  is the proportional coefficient (amplification factor). It is the ratio of the adjustment range  $\Delta Y$  and the proportional range  $\Delta X_d$ .

Characteristic and step response of the P portion of a PID controller

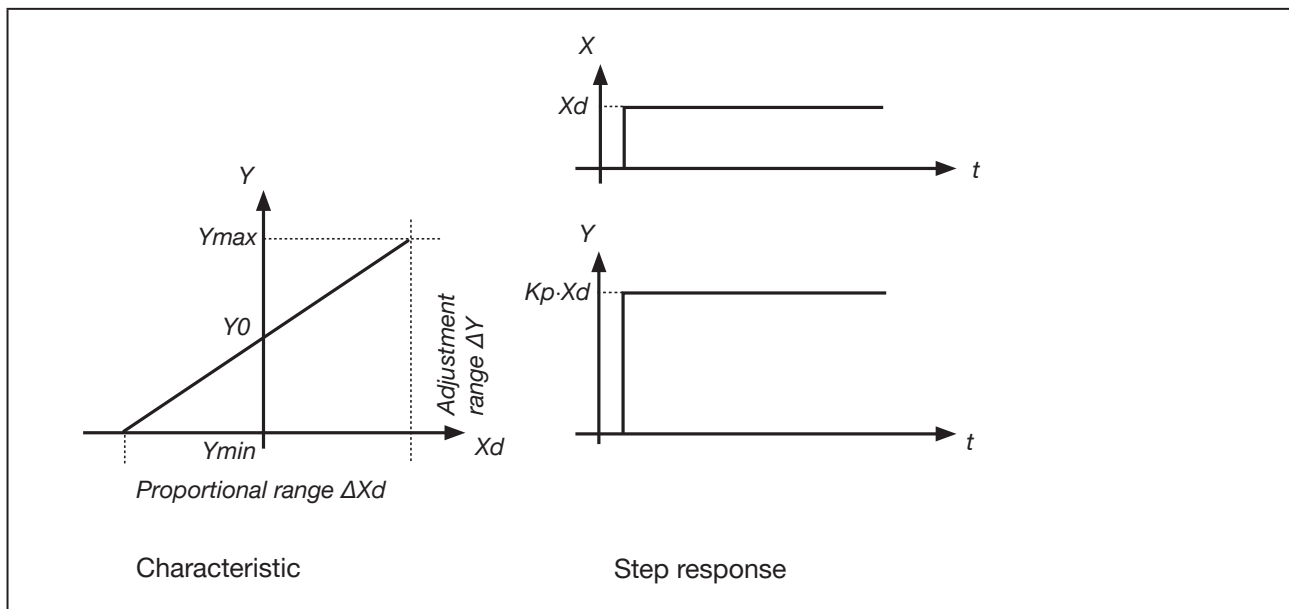


Figure 70: Characteristic and step response of the P portion of a PID controller

#### Properties

In theory a pure P-controller functions instantaneously, i.e. it is quick and therefore dynamically favorable. It has a constant control difference, i.e. it does not fully correct the effects of malfunctions and is therefore statically relatively unfavorable.



## 26.2.2 I portion

Function:

$$Y = \frac{1}{T_i} \int X \, dt \quad (5)$$

$T_i$  is the integral action time or actuating time. It is the time which passes until the actuating variable has run through the whole adjustment range.

Characteristic and step response of the I portion of a PID controller

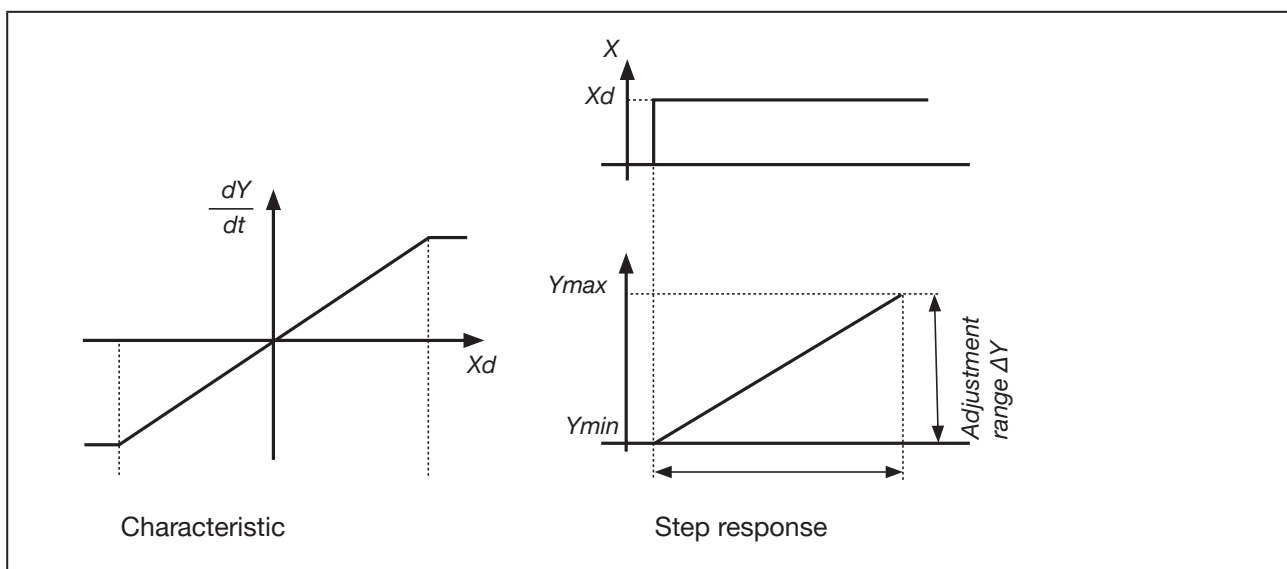


Figure 71: Characteristic and step response of the I portion of a PID controller

### Properties

A pure I-controller completely eliminates the effects of any malfunctions which occur. It therefore has a favorable static behavior. On account of its final control speed control it operates slower than the P-controller and has a tendency to oscillate. It is therefore dynamically relatively unfavorable.

### 26.2.3 D portion

Function:

$$Y = K_d \cdot \frac{dX}{dt} \quad (6)$$

$K_d$  is the derivative action coefficient. The larger  $K_d$  is, the greater the D-effect is.

Characteristic and step response of the D portion of a PID controller

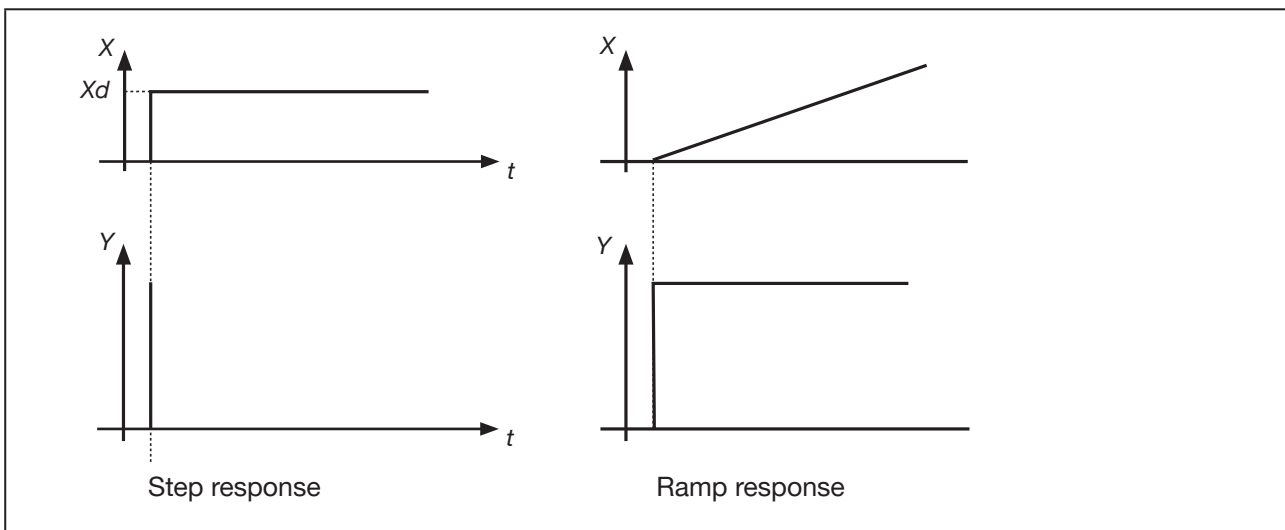


Figure 72: Characteristic and step response of the D portion of a PID controller

#### Properties

A controller with a D portion responds to changes in the control variable and may therefore reduce any control differences more quickly.

## 26.2.4 Superposition of P, I and D portions

Function:

$$Y = K_p \cdot X_d + \frac{1}{T_i} \int X_d dt + K_d \frac{dX_d}{dt} \quad (7)$$

Where  $K_p \cdot T_i = T_n$  and  $K_d/K_p = T_v$  the **function of the PID controller** is calculated according to the following equation:

$$Y = K_p \cdot \left( X_d + \frac{1}{T_n} \int X_d dt + T_v \frac{dX_d}{dt} \right) \quad (8)$$

- $K_p$  Proportional coefficient / amplification factor
- $T_n$  Reset time  
(Time which is required to obtain an equally large change in the actuating variable by the I portion, as occurs due to the P portion)
- $T_v$  Derivative time  
(Time by which a certain actuating variable is reached earlier on account of the D portion than with a pure P controller)

### Step response and ramp response of the PID controller

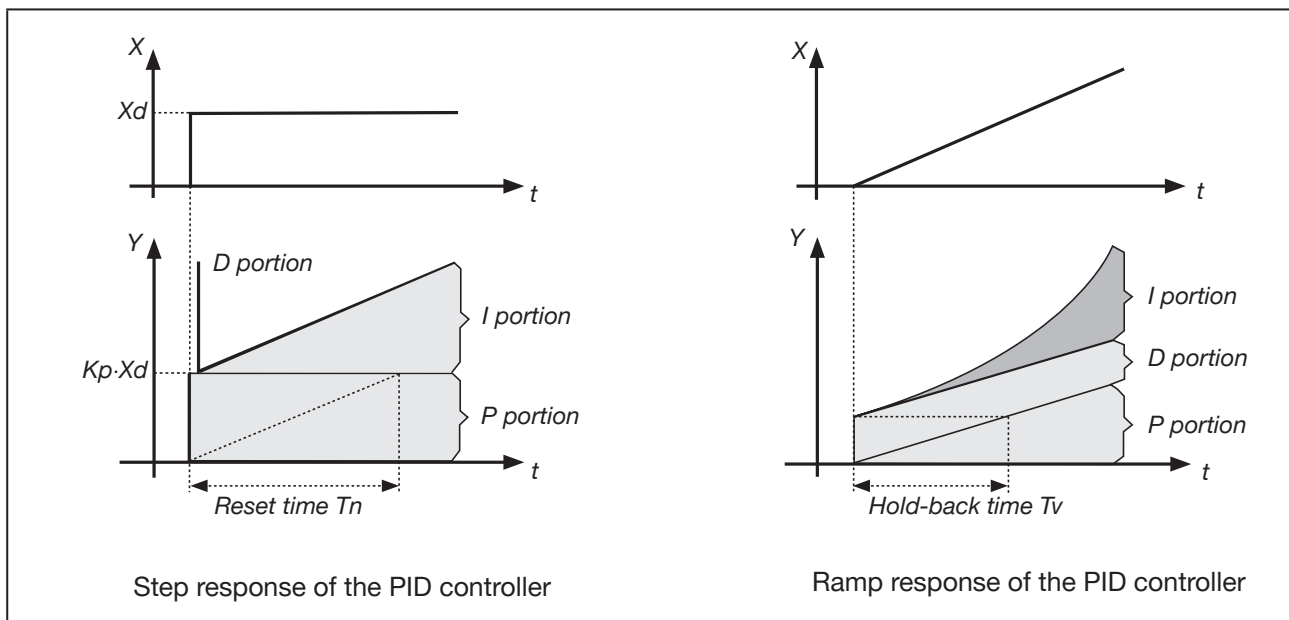


Figure 73: Characteristic of step response and ramp response of PID controller

## 26.2.5 Implemented PID controller

### 26.2.5.1. D portion with delay

In the process controller of the Type 8793 positioner the D portion is implemented with a delay  $T$ .

Function:

$$T \cdot \frac{dY}{dt} + Y = K_d \cdot \frac{dX_d}{dt} \quad (9)$$

Superposition of P, I and DT portions

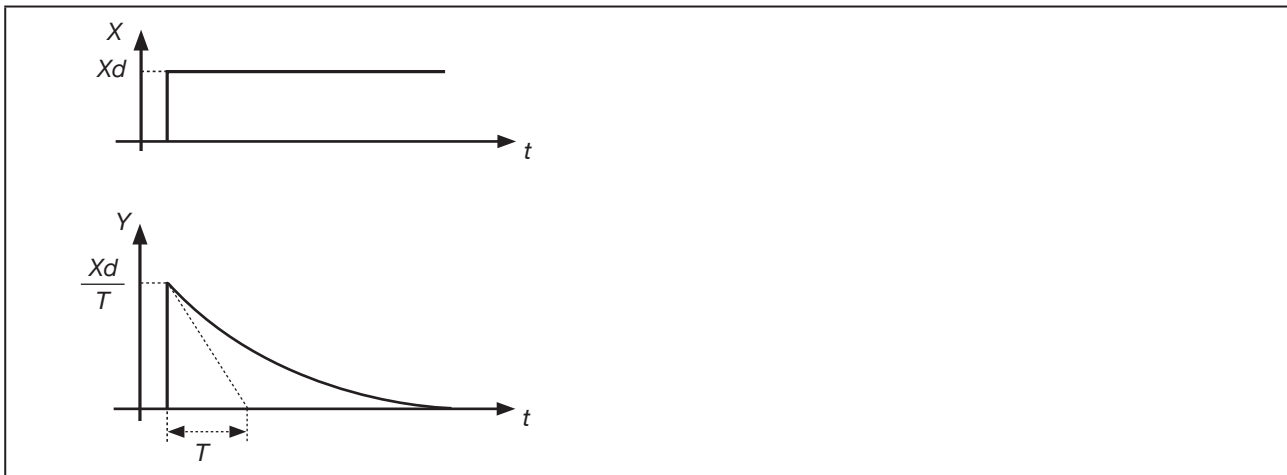


Figure 74: Characteristic of superposition of P, I and DT portions

### 26.2.5.2. Function of the real PID controller

$$T \cdot \frac{dY}{dt} + Y = K_p \left( X_d + \frac{1}{T_n} \int X_d dt + T_v \frac{dX_d}{dt} \right) \quad (10)$$

Superposition of P, I and DT portions

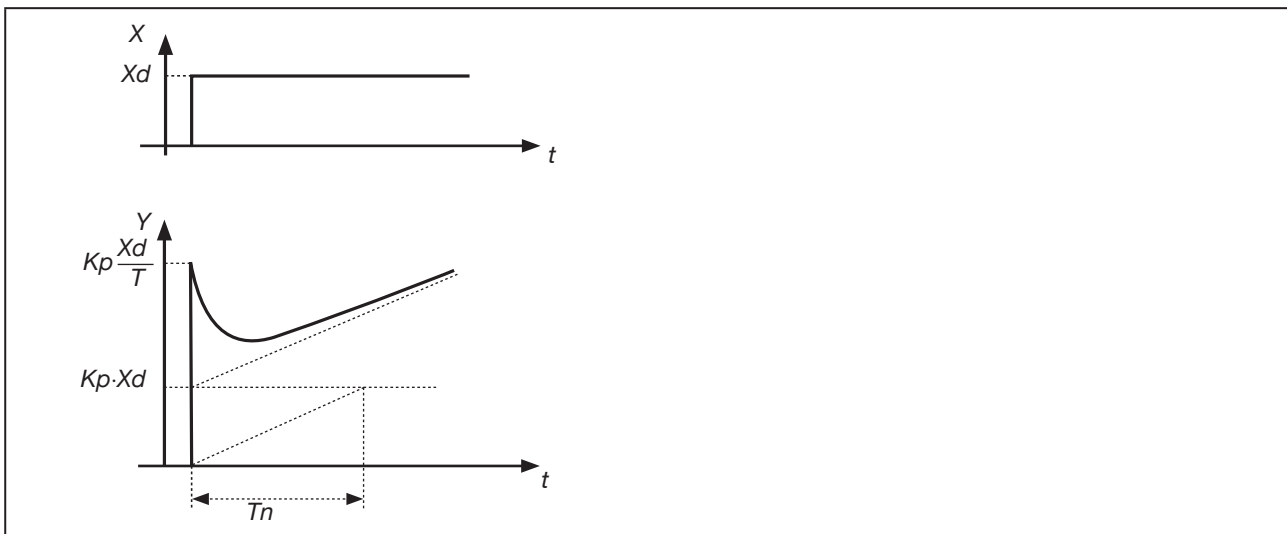


Figure 75: Characteristic of step response of the real PID controller

## 26.3 Adjustment rules for PID controllers

The Type 8793 control system comes with a self-optimization function for the structure and parameters of the integrated process controller. The PID parameters determined can be viewed via the operating menu and empirically re-optimized as desired.

The regulatory literature includes a series of adjustment rules which can be used in experimental ways to determine a favorable setting for the controller parameters. To avoid incorrect settings, always observe the conditions under which the particular adjustment rules have been drawn up. Apart from the properties of the controlled system and the controller itself, the aspect whether a change in the disturbance variable or command variable is to be corrected plays a role.

### 26.3.1 Adjustment rules according to Ziegler and Nichols (oscillation method)

With this method the controller parameters are adjusted on the basis of the behavior of the control circuit at the stability limit. The controller parameters are first adjusted so that the control circuit starts to oscillate. The occurring critical characteristic values suggest a favorable adjustment of the controller parameters. A prerequisite for the application of this method of course is that the control circuit may be oscillated.

#### Procedure

- Set controller as P-controller (i.e.  $T_n = 999$ ,  $T_v = 0$ ), first select a low value for  $K_p$
- Set required set-point value
- Increase  $K_p$  until the control variable initiates an undamped continuous oscillation.

The proportionality coefficient (amplification factor) set at the stability limit is designated as  $K_{crit}$ . The resulting oscillation duration is designated as  $T_{crit}$ .

#### Progress of the control variable at the stability limit

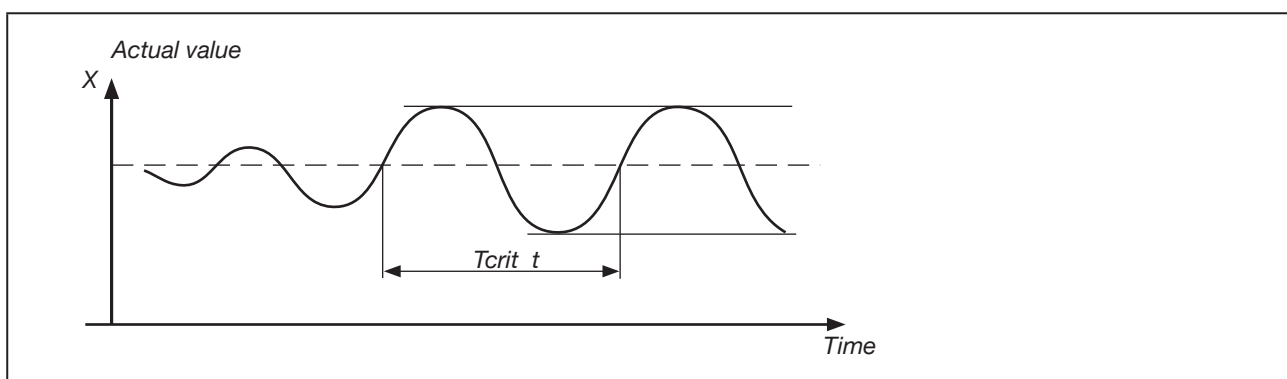


Figure 76: Progress of the control variable PID

The controller parameters can then be calculated from  $K_{crit}$  and  $T_{crit}$  according to the following table.

**Setting the parameters according to Ziegler and Nichols**

Controller type	Setting the parameters		
P controller	$K_p = 0.5 K_{crit}$	-	-
PI controller	$K_p = 0.45 K_{crit}$	$T_n = 0.85 T_{crit}$	-
PID controller	$K_p = 0.6 K_{crit}$	$T_n = 0.5 T_{crit}$	$T_v = 0.12 T_{crit}$

Table 73: *Setting the parameters according to Ziegler and Nichols*

The adjustment rules of Ziegler and Nichols have been determined for P-controlled systems with a time delay of the first order and dead time. However, they apply only to controllers with a disturbance reaction and not to those with a reference reaction.

## 26.3.2 Adjustment rules according to Chien, Hrones and Reswick (Actuating Variable Jump Method)

With this method the controller parameters are adjusted on the basis of the transient behavior of the controlled system. An actuating variable jump of 100% is output. The times  $T_u$  and  $T_g$  are derived from the progress of the actual value of the control variable.

Progress of the control variable following an actuating variable jump  $\Delta Y$

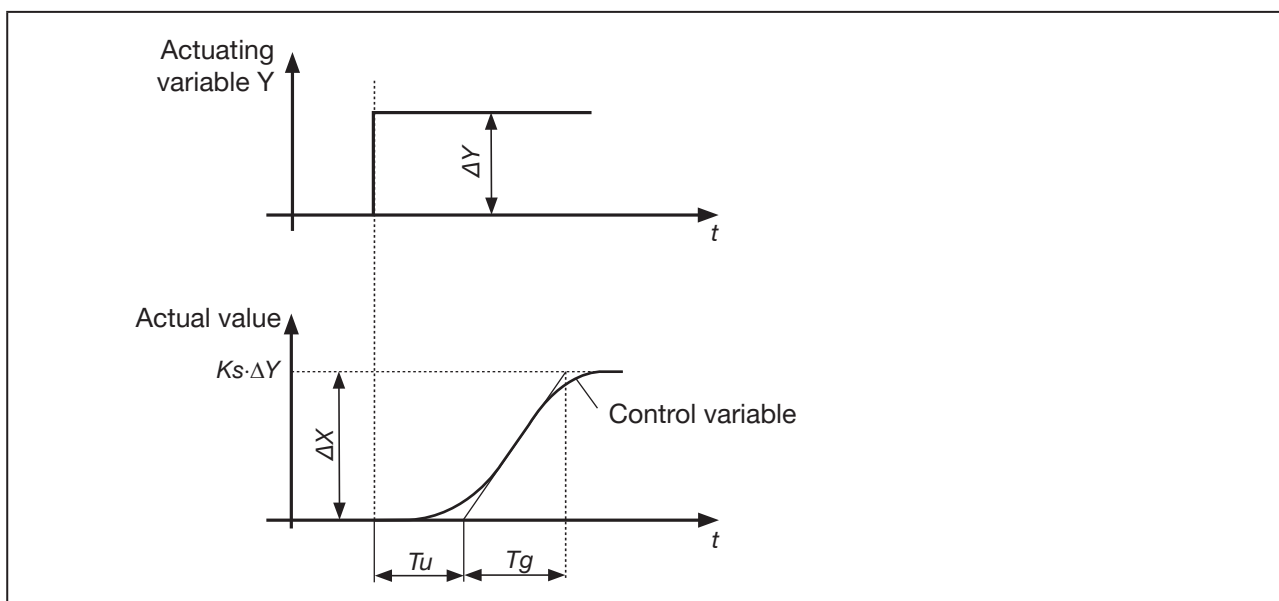


Figure 77: Progress of the control variable, actuating variable jump

### Procedure

- Switch controller to MANUAL (MANU) operating state
- Output the actuating variable jump and record control variable with a recorder
- If progresses are critical (e.g. danger of overheating), switch off promptly.



Note that in thermally slow systems the actual value of the control variable may continue to rise after the controller has been switched off.

In the following “[Table 134](#)” the set values have been specified for the controller parameters, depending on  $T_u$ ,  $T_g$  and  $K_s$  for reference and disturbance reaction, as well as for an aperiodic control process and a control process with a 20% overshoot. They apply to controlled systems with P-behavior, with dead time and with a delay of the first order.

Setting the parameters according to Chien, Hrones and Reswick

Controller type	Setting the parameters			
	for aperiodic control process (0% overshoot)		for control process with 20% overshoot	
	Reference	Malfunction	Reference	Malfunction
P controller	$K_p = 0.3 \cdot \frac{T_g}{T_u \cdot K_s}$	$K_p = 0.3 \cdot \frac{T_g}{T_u \cdot K_s}$	$K_p = 0.7 \cdot \frac{T_g}{T_u \cdot K_s}$	$K_p = 0.7 \cdot \frac{T_g}{T_u \cdot K_s}$
PI controller	$K_p = 0.35 \cdot \frac{T_g}{T_u \cdot K_s}$ $T_n = 1.2 \cdot T_g$	$K_p = 0.6 \cdot \frac{T_g}{T_u \cdot K_s}$ $T_n = 4 \cdot T_u$	$K_p = 0.6 \cdot \frac{T_g}{T_u \cdot K_s}$ $T_n = T_g$	$K_p = 0.7 \cdot \frac{T_g}{T_u \cdot K_s}$ $T_n = 2.3 \cdot T_u$
PID controller	$K_p = 0.6 \cdot \frac{T_g}{T_u \cdot K_s}$ $T_n = T_g$ $T_v = 0.5 \cdot T_u$	$K_p = 0.95 \cdot \frac{T_g}{T_u \cdot K_s}$ $T_n = 2.4 \cdot T_u$ $T_v = 0.42 \cdot T_u$	$K_p = 0.95 \cdot \frac{T_g}{T_u \cdot K_s}$ $T_n = 1.35 \cdot T_g$ $T_v = 0.47 \cdot T_u$	$K_p = 1.2 \cdot \frac{T_g}{T_u \cdot K_s}$ $T_n = 2 \cdot T_u$ $T_v = 0.42 \cdot T_u$

Table 74: Setting the parameters according to Chien, Hrones and Reswick

The proportionality factor  $K_s$  of the controlled system is calculated as follows:

$$K_s = \frac{\Delta X}{\Delta Y} \quad (11)$$



## 27 TABLE FOR YOUR SETTINGS ON THE POSITIONER

### 27.1 Settings of the freely programmed characteristic

Node (position set-point value as%)	Valve stroke [%]			
	Date:	Date:	Date:	Date:
0				
5				
10				
15				
20				
25				
30				
35				
40				
45				
50				
55				
60				
65				
70				
75				
80				
85				
90				
95				
100				

MAN 1000341264 EN Version: C Status: RL (released | freigegeben) printed: 09.12.2019



MAN 1000341264 EN Version: C Status: RL (released | freigegeben) printed: 09.12.2019

