

Type 2030_2031
Pneumatically operated diaphragm valve with CLASSIC actuator



2/2 way diaphragm valve with pneumatic plastic actuator (Type CLASSIC)

- Valve body and diaphragm are available in various materials and variants
- Product wetted surfaces in $Ra \leq 0.38 \dots \leq 1.6 \mu m$ (optionally electro-polished)
- Available in all common connection sizes and variants



Product variants described in the data sheet may differ from the product presentation and description.

Can be combined with

	Type 2034 Multifunction block and weld solution	▶
	Type 3233 2/2 way diaphragm valve with manually operated actuator	▶
	Type 8690 Pneumatic control for decentralised automation of ELEMENT process valves	▶
	Type 8697 Pneumatic control for decentralised automation of ELEMENT process valves	▶

Type description

The externally controlled diaphragm valve Type 2031 consists of a pneumatically operated piston actuator, a diaphragm and a 2-way valve body. The proven and robust actuator with a plastic housing ensures use in hygienic or aggressive ambient conditions. The flow-efficient valve bodies with little dead space enable high flow rates and a wide range of possible uses. The valve body and the diaphragm are available in all common materials and variants. The actuator has a compact, autoclavable design (PPS variant).

The integration of the automation units 8690/8697 is possible in all configuration levels (can be retrofitted). An explosion-proof ATEX / IECEx device variant is available. The add-on body is optionally available in plastic or stainless steel. The actuator is equipped with an integrated, optical position indicator as standard, optionally a min./max. stroke limiter can be installed.

DTS 1000450587 EN Version: B Status: RL (released | freigegeben | validé) printed: 05.02.2021

Table of contents

1. General technical data	3
2. Approvals	4
3. Materials	5
3.1. Chemical Resistance Chart – Bürkert resistApp.....	5
3.2. Pressure temperature diagram for plastic body.....	5
3.3. Material specifications	6
3.4. Example of available membrane materials	7
4. Dimensions	7
4.1. Actuator	7
CLASSIC actuator.....	7
CLASSIC actuator with block mounting interface (MT85).....	8
CLASSIC actuator with control unit Type 8697	9
4.2. Forged body (VS) with welded connection	10
4.3. Forged body (VS) with clamp connection	12
4.4. Tube valve body (VP) with welded connection	13
4.5. Tube valve body (VP) with clamp connection	14
4.6. Tube valve body (VP) with threaded connection.....	15
4.7. Tube valve body (VP) with flange connection	16
4.8. Cast body (VG) with welded connection	17
4.9. Cast body (VG) with clamp connection	19
4.10. Plastic body (PV; PD; PP) with spigot connection.....	20
4.11. Plastic body (PV, PD, PP) with true union	21
4.12. Plastic body (PV, PD, PP) with flange connection	22
5. Performance specifications	23
5.1. Flow characteristics	23
Forged body (VS)	23
Tube valve body (VP)	23
Cast body (VG).....	24
Plastic body (PV; PD; PP)	24
5.2. Medium pressure.....	24
6. Product accessories	25
7. Networking and combination with other Bürkert products	26
8. Ordering information	27
8.1. Bürkert eShop – Easy ordering and quick delivery.....	27
8.2. Bürkert product filter.....	27
8.3. Bürkert product enquiry form	27

1. General technical data

Product properties	
Dimensions	Detailed information can be found in chapter "4. Dimensions" on page 7.
Material	
Forged body (VS) ¹⁾	Forged stainless steel 316L/1.4435/BN2, Fe < 0.5 %/C ≤ 0.03 %
Tube valve body (VP) ¹⁾	Stainless steel 316L/1.4435/BN2
Cast body (VG) ¹⁾	Cast stainless steel 316L/1.4435
Plastic body (PV; PP; PD) ¹⁾	PVC (PVC-U); PP; PVDF
Diaphragm	EPDM (AD) ¹⁾ , PTFE/EPDM (EA) ¹⁾ , advanced PTFE/EPDM (EU) ¹⁾ , Gylon®/EPDM laminated (ER) ¹⁾
Actuator	PPS, PA
Diaphragm size	8...100; for tube valve body 8...50 mm; for plastic body 15...100
Standard surface quality	
Forged body (VS) ¹⁾	Internal electrically polished : Ra ≤ 0.38 µm (NO17) ¹⁾ (ASME BPE SF4/DIN HE4) (external forged surface electrically polished) Internal mechanically polished : Ra ≤ 0.5 µm (NO14) ¹⁾ (ASME BPE SF1) (external forged surface)
Tube valve body (VP) ¹⁾	Internal electrically polished : Ra ≤ 0.38 µm (NO17) ¹⁾ (ASME BPE SF4/DIN HE4) External glass bead blasted: Ra ≤ 1.6 µm (NO01) ¹⁾ Internal glass bead blasted: Ra ≤ 1.6 µm (NO05) ¹⁾
Cast body (VG) ¹⁾	Internal electrically polished : Ra ≤ 0.6 µm (NO16) ¹⁾ (ASME BPE SF6) (external cast surface electrically polished) Internal mechanically polished : Ra ≤ 0.76 µm (NO06) ¹⁾ (ASME BPE SF3/DIN H2) (external cast surface)
Performance data	
Pilot pressure (max.)	7 bar (for actuator size 40 ¹⁾ ...125 ¹⁾ /PPS) 6 bar (for actuator size 175 ¹⁾ and 225 ¹⁾ /PA) See "5.2. Medium pressure" on page 24
Pilot air port	Thread G ¼; thread G ⅜ for actuator size 40 and 50
Medium data	
Medium	Neutral gases and fluids, highly purified, sterile, aggressive or abrasive medium (see Resistance Chart ▶)
Medium temperature	
EPDM (AD) ¹⁾	-10...+143 °C (steam sterilisation + 150 °C for 60 min)
PTFE/EPDM (EA) ¹⁾	-10...+130 °C (steam sterilisation + 140 °C for 60 min)
Advanced PTFE/EPDM (EU) ¹⁾	-5...+143 °C (steam sterilisation + 150 °C for 60 min)
GYLON®/EPDM laminated (ER) ¹⁾	-5...+130 °C (steam sterilisation + 140 °C for 60 min)
Plastic body	See "3.2. Pressure temperature diagram for plastic body" on page 5
Control medium	Neutral gases, air
Process/Port connection & communication	
Nominal diameter	DN06...DN100 (¼" ... 4")
Port connections²⁾	
For stainless steel body³⁾	
Welded connection ²⁾	DIN EN ISO 1127/ISO 4200/DIN 11866 series B DIN 11850 series 2/DIN 11866 series A/DIN EN 10357 series A ASME BPE/DIN 11866 series C
Clamp connection ²⁾	DIN 32676 series A (DIN pipe) DIN 32676 series B (ISO pipe) ASME BPE
For plastic body	
Spigot connection	DN15...DN50
True union	DN15...DN50
Loose flange	DN15...DN65
Fixed flange	DN80...DN100

Environment and installation

Installation position/Installation See **operating manual** ▶

Ambient temperature





PPS Actuator size ≤ 80 mm	+5...140°C ^{5.)}
PPS Actuator size 100 mm, 125 mm	+5...90 °C (briefly at + 140 °C) ^{5.)}
PA Actuator size ≤ 125 mm	-10...+60°C ^{5.)}
PA Actuator size ≥ 175 mm	-10...+50°C ^{5.)}

- 1.) This information is part of the product key (see product enquiry form at the end of this data sheet)
- 2.) Further versions on request
- 3.) Tube valve body (VP) also available with flange and threaded connections
- 4.) With plastic housings temperature limitation by housing material possible
- 5.) For standard version

2. Approvals

Note:

If you need one of these certificates, please contact your Bürkert partner.

Approvals/ Conformity/ Certificate ^{1.)}	Description
	ATEX/IECEX^{2.)} EPS 18 ATEX 2 008 X II 2G Ex h IIC T4 Gb/II 2D Ex h IIIC T135 °C Db IECEX EPS 18.0007X Ex h IIC T4 Gb/Ex h IIIC T135 °C Db
TA air	TA air ^{3.)}
	3-A (3-A Sanitary Standards Symbol Administrative Council) ^{4.)}
	EHEDG (European Hygienic Engineering & Design Group) ^{5.) 6.)}
	The diaphragms made of EPDM (AD), PTFE/EPDM (EA), advanced PTFE/EPDM (EU) and GYLON®/EPDM laminated (ER) are suitable for use with food and beverages (acc. to EC Regulation 1935/2004/EC).
	Diaphragms made of EPDM (AD), PTFE/EPDM (EA), advanced PTFE/EPDM (EU) and GYLON®/EPDM laminated (ER) are acc. to USP Class VI tested.
FDA	Diaphragms made of EPDM (AD), PTFE/EPDM (EA), advanced PTFE/EPDM (EU) and GYLON®/EPDM laminated (ER) comply with the Code of Federal Regulations published by the FDA (Food and Drug Administration, USA).

- 1.) Further approvals/conformity clarification/certificates on request
- 2.) Only in combination with variable code «PX51» (see product enquiry form at the end of this data sheet)
- 3.) Only in combination with variable code «PM01» (see product enquiry form at the end of this data sheet)
- 4.) Only in combination with variable code «PE05» (see product enquiry form at the end of this data sheet)
- 5.) For forged bodies only in connection with variable code «PI01» (see product enquiry form at the end of this data sheet)
- 6.) For all versions of the pipe forming body with EPDM or PTFE diaphragm

3. Materials

3.1. Chemical Resistance Chart – Bürkert resistApp

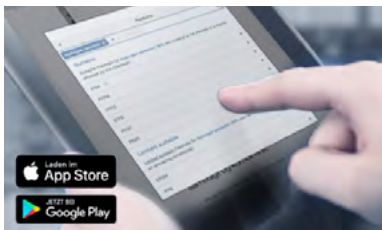

Bürkert resistApp – Chemical Resistance Chart

You want to ensure the reliability and durability of the materials in your individual application case? Verify your combination of media and materials on our website or in our resistApp.

Start Chemical Resistance Check

3.2. Pressure temperature diagram for plastic body

Note:

This information is important for material selection. Observe the permissible operating pressure depending on the medium temperature.

DN15...50

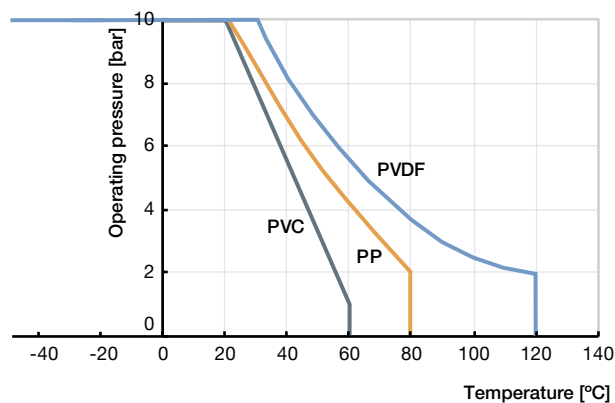

DN65...100

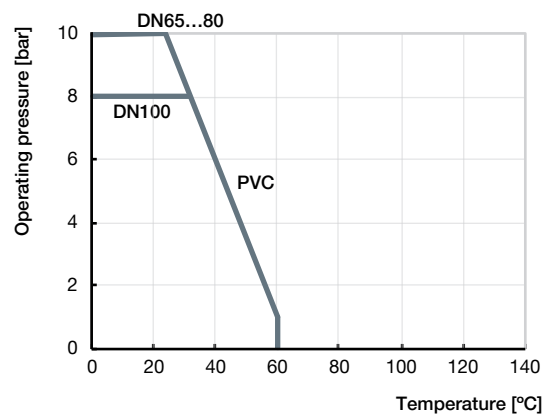

3.3. Material specifications

Actuator size 40...125

Note:

Exemplary representation may differ from the actual product.

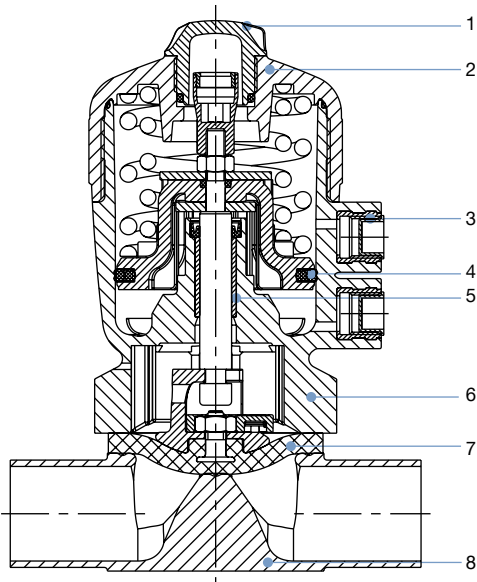

No.	Element	Material
1	Transparent cap	Polysulfone PSU
2	Cover	Polyphenylene sulphide PPS (standard) Polyamide PA (on request)
3	Pilot air ports	Stainless steel 1.4305
4	Piston seal	FKM
5	Socket	Sinter metal
6	Interface	Polyphenylene sulphide PPS (Standard) Polyamide PA (on request) Stainless steel 1.4404 (on request)
7	Diaphragm	EPDM (AD), PTFE/EPDM (EA), ad- vanced PTFE/EPDM (EU), Gylon®/ EPDM laminated (ER)
8	Valve body	See "1. General technical data" on page 3

Actuator size 175 and 225

Note:

Exemplary representation may differ from the actual product.

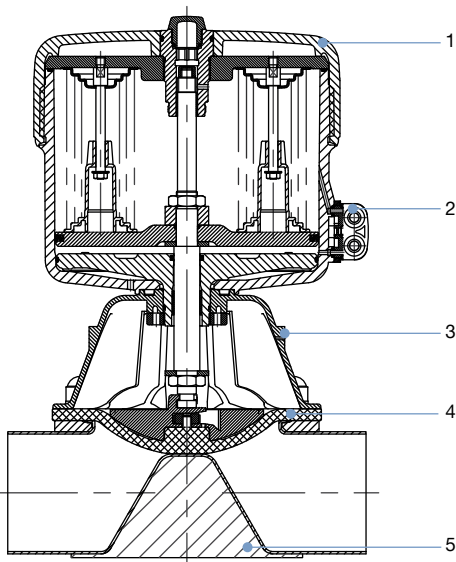

No.	Element	Material
1	Cover	Polyamide PA
2	Pilot air ports	Stainless steel 1.4305
3	Attachment housing	Stainless steel 1.4308
4	Diaphragm	EPDM (AD), PTFE/EPDM (EA), ad- vanced PTFE/EPDM (EU), Gylon®/ EPDM laminated (ER)
5	Valve body	See "1. General technical data" on page 3

3.4. Example of available membrane materials

The diaphragms have been developed to meet the unique challenges of hygienic and sterile requirements. Bürkert offers diaphragms with precise material composition and high accuracy. Bürkert diaphragms are available in a wide range of materials which have been tested and proven in applications in the food and beverage, biotechnology, pharmaceutical and cosmetics industries. The diaphragms are tested during development and production to ensure reliability under difficult process conditions.



- EPDM (AD)
- PTFE/EPDM (EA)
- advanced PTFE/EPDM (EU)
- Gylon®/EPDM laminated (ER)

For further information please refer to our flyer "Diaphragm competence for hygienic applications" on our [website](#) ▶.

4. Dimensions

4.1. Actuator

CLASSIC actuator

Note:

Dimensions in mm, unless otherwise stated

Diaphragm size 8...50

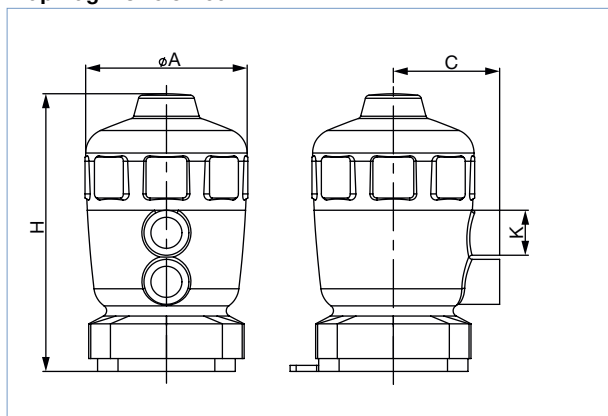

Diaphragm size 65...100

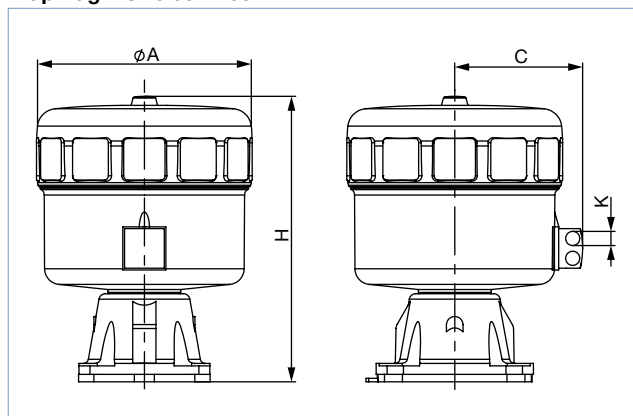

Diaphragm size	Actuator size Ø	ØA	C	K	H
8	40 (C)	53	34	G 1/8"	89
15	50 (D)	64	39	G 1/8"	108
	63 (E)	80	52	G 1/4"	125
20	63 (E)	80	52	G 1/4"	131
	80 (F)	101	60	G 1/4"	152
25	63 (E)	80	52	G 1/4"	136
	80 (F)	101	60	G 1/4"	156
40	100 (G)	127	73	G 1/4"	205
	125 (H)	153	86	G 1/4"	243
50	100 (G)	127	73	G 1/4"	207
	125 (H)	153	86	G 1/4"	242
65	175 (K)	211	130	G 1/4"	350
80	175 (K)	211	130	G 1/4"	350
	225 (L)	261	155	G 1/4"	345
100	225 (L)	261	155	G 1/4"	345

Type 2030_2031
Pneumatically operated diaphragm
valve with CLASSIC actuator

CLASSIC actuator with block mounting interface (MT85)

Note:

Dimensions in mm, unless otherwise stated

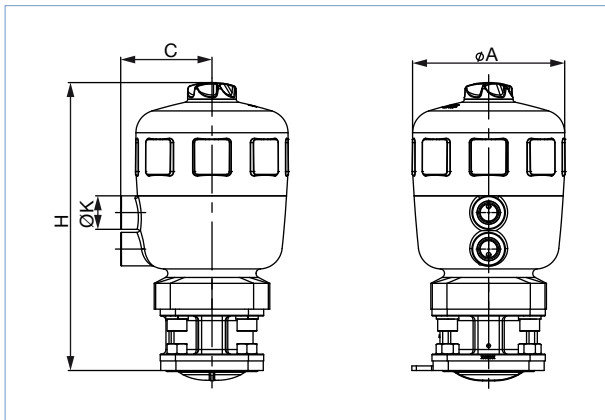

Diaphragm size	Actuator size Ø	H	ØA	C	K
8	40 (C)	111	53	34	G 1/8"
15	50 (D)	137	64	39	G 1/8"
	63 (E)	154	80	52	G 1/4"
20	63 (E)	165	80	52	G 1/4"
	80 (F)	186	101	52	G 1/4"
25	63 (E)	170	80	52	G 1/4"
	80 (F)	190	101	60	G 1/4"
40	100 (G)	246	127	73	G 1/4"
	125 (H)	284	158	86	G 1/4"
50	100 (G)	254	127	73	G 1/4"
	125 (H)	288	158	86	G 1/4"

Type 2030_2031
Pneumatically operated diaphragm
valve with CLASSIC actuator

CLASSIC actuator with control unit Type 8697

Note:

Dimensions in mm, unless otherwise stated

Control unit
Diaphragm size 8...50

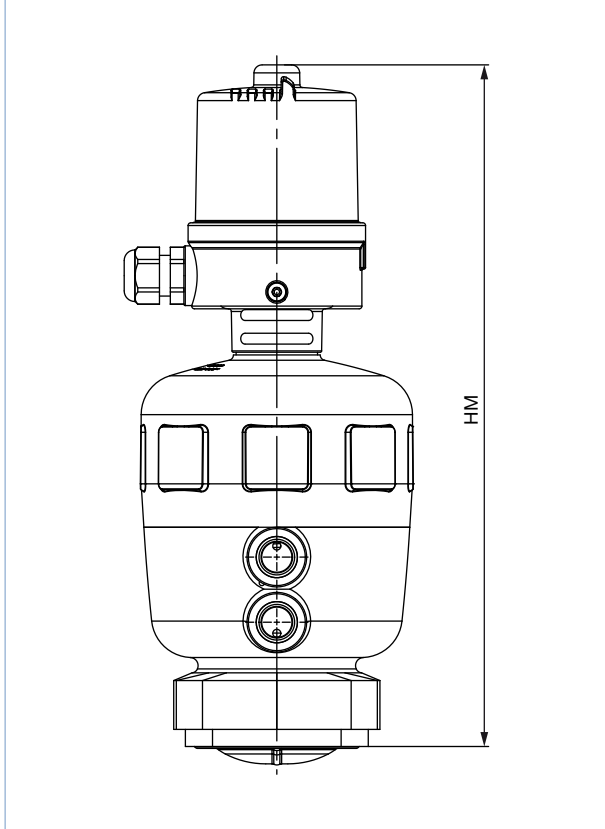

Control unit MT85
Diaphragm size 8...50

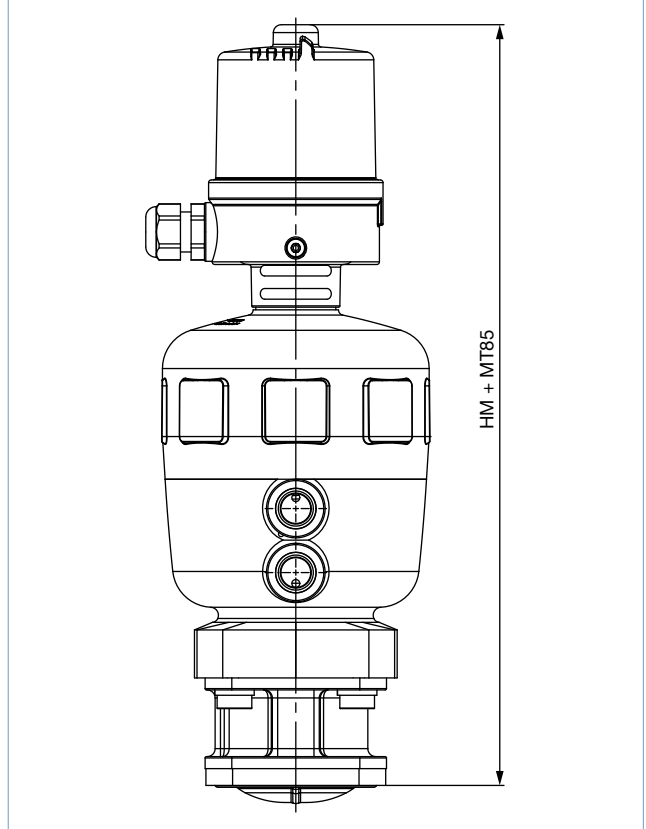

Diaphragm size	Actuator size Ø	HM	HM + MT85
8	40 (C)	185	207
15	50 (D)	204	233
	63 (E)	220	249
20	63 (E)	227	261
	80 (F)	247	281
25	63 (E)	232	266
	80 (F)	252	286
40	100 (G)	298	339
	125 (H)	336	377
50	100 (G)	301	347
	125 (H)	335	381

4.2. Forged body (VS) with welded connection

Note:

- Dimensions in mm, unless otherwise stated
- For detailed information on the draining angle, please refer to the “Additional manual Type 2xxx 3xxx” on our website (see [operating instructions](#) ▶).

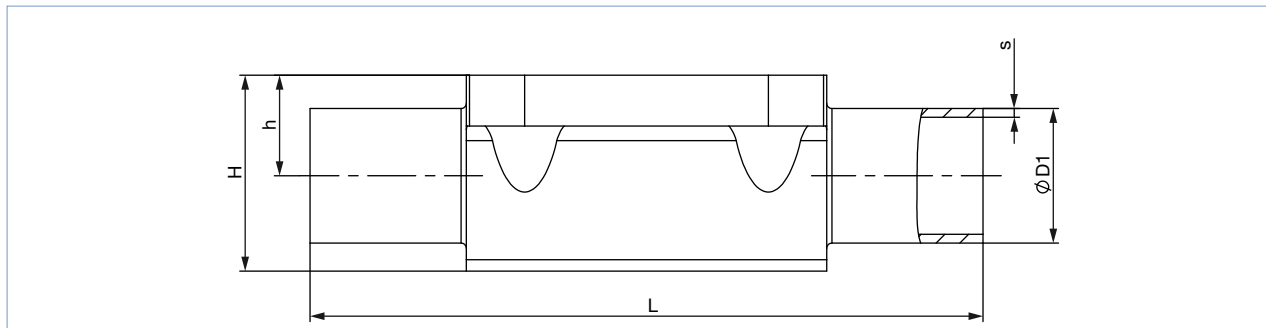

Diaphragm size	Port connection DN	ØD1	s	L	h	H	Product key ^{1,)}
DIN EN ISO 1127/ISO 4200/DIN 11866 series B							
8	8	13.5	1.6	90	9.3	18.8	SA40
15	8	13.5	1.6	108	8.15	19.85	SA40
8	10	17.2	1.6	90	9.3	18.8	SA41
15	10	17.2	1.6	110	12.05	23.75	SA41
15	15	21.3	1.6	110	12.05	23.75	SA42
20	15	21.3	1.6	119	16	30.3	SA42
20	20	26.9	1.6	119	16	30.3	SA43
25	20	26.9	1.6	119	19	37	SA43
25	25	33.7	2.0	129	19	37	SA44
40	25	33.7	2.0	161	27.6	52.4	SA44
40	32	42.4	2.0	161	27.6	52.4	SA45
40	40	48.3	2.0	161	27.6	52.4	SA46
50	50	60.3	2.0	192	35.5	68.3	SA47
80	65	76.1	2.0	250	51	98.1	SA48
80	80	88.9	2.3	250	51	98.1	SA49
DIN 11850 series 2/DIN 11866 series A/DIN EN 10357 series A							
8	10	13	1.5	90	9.3	18.8	SD40
15	10	13	1.5	110	8.15	19.85	SD40
15	15	19	1.5	110	12.05	23.75	SD42
20	20	23	1.5	119	16.0	30.3	SD43
25	25	29	1.5	129	19.0	37.0	SD44
40	32	35	1.5	161	27.6	52.4	SD45
40	40	41	1.5	161	27.6	52.4	SD46
50	50	53	1.5	192	35.5	68.3	SD47
80	65	70	2.0	250	51.0	98.1	SD48
80	80	85	2.0	250	51.0	98.1	SD49

Type 2030_2031
Pneumatically operated diaphragm
valve with CLASSIC actuator



Diaphragm size	Port connection DN	ØD1	s	L	h	H	Product key ^{1.)}
ASME BPE/DIN 11866 series C							
8	¼"	6.35	0.89	78	5.7	15.2	SA90
8	⅜"	9.53	0.89	89	5.7	15.2	SA91
8	½"	12.7	1.65	89	9.3	18.8	SA92
15	½"	12.7	1.65	108	8.15	19.85	SA92
15	¾"	19.05	1.65	108	12.05	23.75	SA93
20	¾"	19.05	1.65	117	16.0	30.3	SA93
25	1"	25.4	1.65	127	19.0	37.0	SODF
40	1½"	38.1	1.65	159	27.6	52.4	SODH
50	2"	50.8	1.65	190	35.5	68.3	SODI
50	2½"	63.5	1.65	192	35.5	68.6	SODJ
80	2½"	63.5	1.65	250	51.0	98.1	SODJ
80	3"	76.2	1.65	250	51.0	98.1	SODK
BS 4825							
8	8	6.35	1.20	78	5.7	15.2	SODB
8	10	9.53	1.20	89	5.7	15.2	SODC
15	15	12.7	1.20	108	8.15	19.85	SODD
20	20	19.05	1.20	117	16.0	30.3	SODE
25	25	25.4	1.65	127	19.0	37.0	SODF
40	40	38.1	1.65	159	27.6	52.4	SODH
50	50	50.8	1.65	190	35.5	68.3	SODI
50	65	63.5	1.65	192	35.5	68.6	SODJ
80	80	63.5	1.65	250	51.0	98.1	SODJ
80	80	76.2	1.65	250	51.0	98.1	SODK
SMS 3008							
25	25	25	1.2	129	19	37	SA60
40	40	38	1.2	161	27.6	52.4	SA62
50	50	51	1.2	192	35.5	68.3	SA63
DIN 11850 series 0							
8	6	8	1.0	90	5.7	15.2	SC41
8	8	10	1.0	90	5.7	15.2	SC42

1.) This information is part of the product key (see product enquiry form at the end of this data sheet)

4.3. Forged body (VS) with clamp connection

Note:

- Dimensions in mm, unless otherwise stated
- For detailed information on the draining angle, please refer to the “Additional manual Type 2xxx 3xxx” on our website (see [operating instructions](#) ▶).

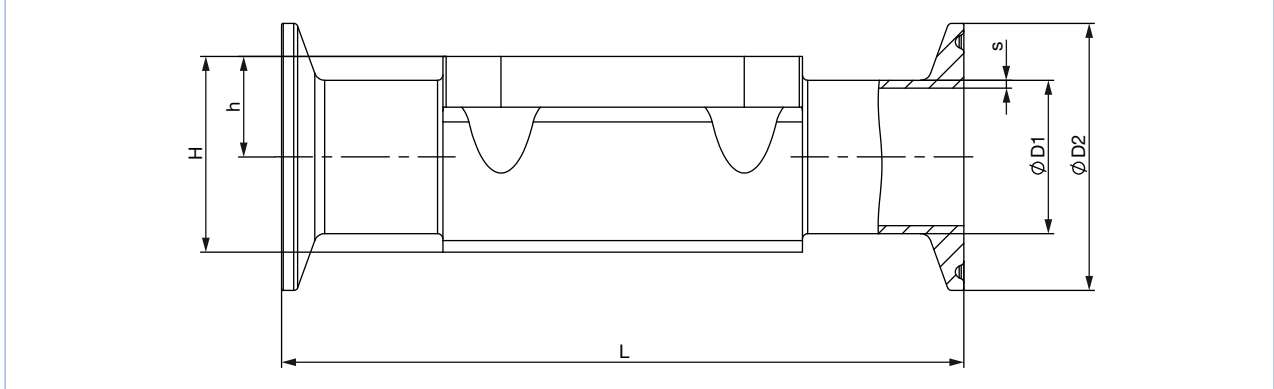

Diaphragm size	Port connection DN	ØD1	s	ØD2	L	h	H	Product key ^{1.)}	Variable code ^{1.)}
DIN 32676 series B (ISO pipe)									
15	15	21.3	1.6	50.5	167	12.05	23.75	TC53	–
20	20	26.9	1.6	50.5	114	16.0	30.3	TC43	–
25	25	33.7	2	50.5	129	19	37	TC44	–
40	40	48.3	2	64.0	161	27.6	52.4	TC46	–
50	50	60.3	2	77.5	190	35.5	68.3	TC47	–
DIN 32676 series A (DIN pipe)									
8	10	13	1.5	34.0	126	9.3	18.8	TD41	–
15	10	13	1.5	34.0	110	8.15	19.85	TD41	–
15	15	19	1.5	34.0	110	12.05	23.75	TD42	–
20	20	23	1.5	34.0	119	16	30.3	TD43	–
25	25	29	1.5	50.5	129	19	37	TD44	–
40	40	41	1.5	50.5	161	27.6	52.4	TD46	–
50	50	53	1.5	64.0	192	35.5	68.3	TD47	–
ASME BPE									
8	¼"	6.35	0.89	25.0	64.5	5.7	15.2	TG50	–
8	⅜"	9.53	0.89	25.0	89	5.7	15.2	TG01	AF34
8	½"	12.7	1.65	25.0	64	9.3	18.8	TG02	–
8	½"	12.7	1.65	25.0	89	9.3	18.8	TG02	AF34
15	½"	12.7	1.65	25.0	89	8.15	19.85	TG02	–
15	½"	12.7	1.65	25.0	108	8.15	19.85	TG02	AF34
15	¾"	19.05	1.65	25.0	89	12.05	23.75	TG03	–
20	¾"	19.05	1.65	25.0	102	16	30.3	TG03	–
20	¾"	19.05	1.65	25.0	117	16	30.3	TG03	AF34
25	1"	25.4	1.65	50.5	114	19	37	TG04	–
25	1"	25.4	1.65	50.5	127	19	37	TG04	AF34
40	1½"	38.1	1.65	50.5	140	27.6	52.4	TG05	–
40	1½"	38.1	1.65	50.5	159	27.6	52.4	TG05	AF34
50	2"	50.8	1.65	64.0	159	35.5	68.3	TG06	–
50	2"	50.8	1.65	64.0	190	35.5	68.3	TG06	AF34
65	2½"	63.5	1.65	77.5	249	43	83.5	TG07	–
80	2½"	63.5	1.65	77.5	216	51	98.1	TG07	–
80	3"	76.2	1.65	91.0	222	51	98.1	TG08	–

1.) This information is part of the product key (see product enquiry form at the end of this data sheet)

4.4. Tube valve body (VP) with welded connection

Note:

- Dimensions in mm, unless otherwise stated
- For detailed information on the draining angle, please refer to the “Additional manual Type 2xxx 3xxx” on our website (see [operating instructions](#) ▶).

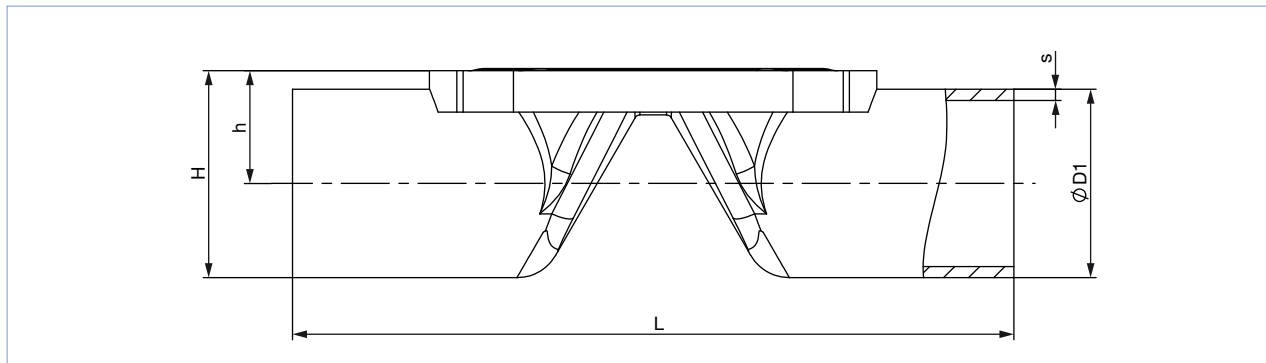

Diaphragm size	Port connection DN	ØD1	s	L	h	H	Product key ^{1.)}
DIN EN ISO 1127/ISO 4200/DIN 11866 series B							
8	8	13.5	1.6	90.0	9.85	16.6	SA40
8	10	17.2	1.6	90.0	11.70	20.3	SA41
15	15	21.3	1.6	110.0	14.35	25.0	SA42
20	20	26.9	1.6	119.0	17.15	30.45	SA43
25	25	33.7	2.0	129.0	20.55	37.4	SA44
32	32	42.4	2.0	148.0	25.10	46.3	SA45
40	40	48.3	2.0	161.0	29.35	53.5	SA46
50	50	60.3	2.0	192.0	35.35	65.50	SA47
DIN 11850 series 2/DIN 11866 series A/DIN EN 10357 series A							
8	10	13	1.5	90	9.85	16.35	SD40
15	15	19	1.5	110	13.20	22.70	SD42
15	20	23	1.5	119	15.20	26.70	SD43
20	25	29	1.5	129	18.20	32.70	SD44
25	32	35	1.5	148	21.20	38.70	SD45
32	40	41	1.5	161	24.40	44.90	SD46
40	50	53	1.5	192	31.70	58.20	SD47
ASME BPE/DIN 11866 series C							
8	½"	12.7	1.65	90.0	9.45	21.95	SA92
15	¾"	19.05	1.65	117.0	13.23	25.73	SA93
20	1"	25.4	1.65	127.0	16.40	41.65	SODF
32	1½"	38.1	1.65	159.0	22.95	48.20	SODH
40	2"	50.8	1.65	190	30.60	62.60	SODI

1.) This information is part of the product key (see product enquiry form at the end of this data sheet)

4.5. Tube valve body (VP) with clamp connection

Note:

- Dimensions in mm, unless otherwise stated
- For detailed information on the draining angle, please refer to the “Additional manual Type 2xxx 3xxx” on our website (see operating instructions ▶).

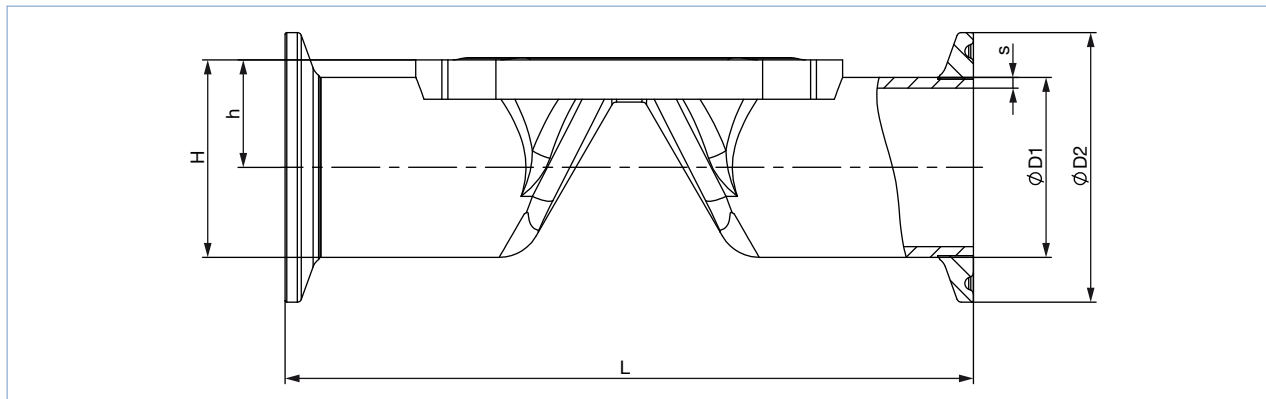

Diaphragm size	Port connection DN	ØD1	s	ØD2	L	h	H	Product key ^{1.)}
DIN 32676 series B (ISO pipe)								
8	8	13.5	1.6	25.0	89	9.85	22.35	TC40
8	10	17.2	1.6	25.0	89	11.70	24.20	TC53
15	15	21.3	1.6	50.5	110	14.35	39.60	TC52
20	20	26.9	1.6	50.5	119	17.15	42.40	TC43
25	25	33.7	2.0	50.5	129	20.55	45.80	TC44
32	32	42.4	2.0	64.0	148	25.10	57.10	TC55
40	40	48.3	2.0	64.0	161	29.35	61.35	TC46
50	50	60.3	2.0	77.5	192	35.35	74.10	TC47
DIN 32676 series A (DIN pipe)								
8	10	13.0	1.5	34.0	89	9.85	26.85	TD41
15	15	19.0	1.5	34.0	110	13.2	30.20	TD42
15	20	23.0	1.5	34.0	119	15.20	32.20	TD43
20	25	29.0	1.5	50.5	129	18.20	43.45	TD44
25	32	35.0	1.5	50.5	148	21.20	46.45	TD45
32	40	41.0	1.5	50.5	161	24.40	49.65	TD46
40	50	53.0	1.5	64.0	192	31.70	63.70	TD47
ASME BPE								
8	1/2"	12.7	1.65	25.0	89	9.45	21.95	TG02
15	3/4"	19.05	1.65	25.0	102	13.20	25.73	TG03
20	1"	25.4	1.65	50.5	114	16.40	41.65	TG04
32	1 1/2"	38.10	1.65	50.5	140	22.95	48.20	TG05
40	2"	50.80	1.65	64.0	159	30.60	62.60	TG06

1.) This information is part of the product key (see product enquiry form at the end of this data sheet)

4.6. Tube valve body (VP) with threaded connection

Note:

- Dimensions in mm, unless otherwise stated
- For detailed information on the draining angle, please refer to the “Additional manual Type 2xxx 3xxx” on our website (see [operating instructions](#) ▶).

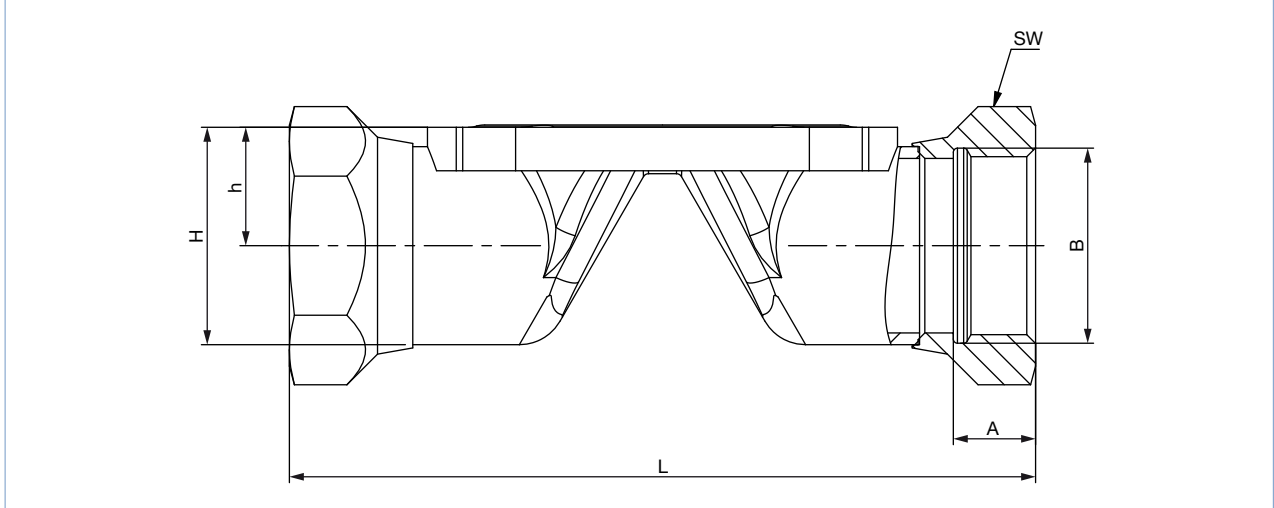

Diaphragm size	L	A	B	h	H	Spanner width of threaded ports	Product key ^{1.)}
08	85	9	G ¼	11.70	20.3	17	GM82
15	102	14	G ½	14.35	25.0	27	GM84
20	118	12	G ¾	17.15	30.45	32	GM85
25	127	14	G 1	20.55	37.4	41	GM86
32	146	16	G 1¼	25.10	46.3	50	GM87
40	159	18	G 1½	29.35	53.5	60	GM88
50	191	20	G 2	35.35	65.50	70	GM89
Diaphragm size	L	A	B	h	H	Spanner width of threaded ports	Product key ^{1.)}
08	85	9.7	Rc ¼	11.70	20.3	17	RC82
15	102	13.2	Rc ½	14.35	25.0	27	RC84
20	118	14.5	Rc ¾	17.15	30.45	32	RC85
25	127	16.8	Rc 1	20.55	37.4	41	RC86
32	146	19.1	Rc 1¼	25.10	46.3	50	RC87
40	159	19.1	Rc 1½	29.35	53.5	60	RC88
50	191	23.4	Rc 2	35.35	65.50	70	RC89
Diaphragm size	L	A	B	h	H	Spanner width of threaded ports	Product key ^{1.)}
08	85	10	NPT ¼	11.70	20.3	17	NM82
15	102	13.7	NPT ½	14.35	25.0	27	NM84
20	118	14	NPT ¾	17.15	30.45	32	NM85
25	127	16.8	NPT 1	20.55	37.4	41	NM86
32	146	17.3	NPT 1¼	25.10	46.3	50	NM87
40	159	17.3	NPT 1½	29.35	53.5	60	NM88
50	191	17.6	NPT 2	35.35	65.50	70	NM89

1.) This information is part of the product key (see product enquiry form at the end of this data sheet)

4.7. Tube valve body (VP) with flange connection

Note:

- Dimensions in mm, unless otherwise stated
- For detailed information on the draining angle, please refer to the “Additional manual Type 2xxx 3xxx” on our website (see [operating instructions](#) ▶).

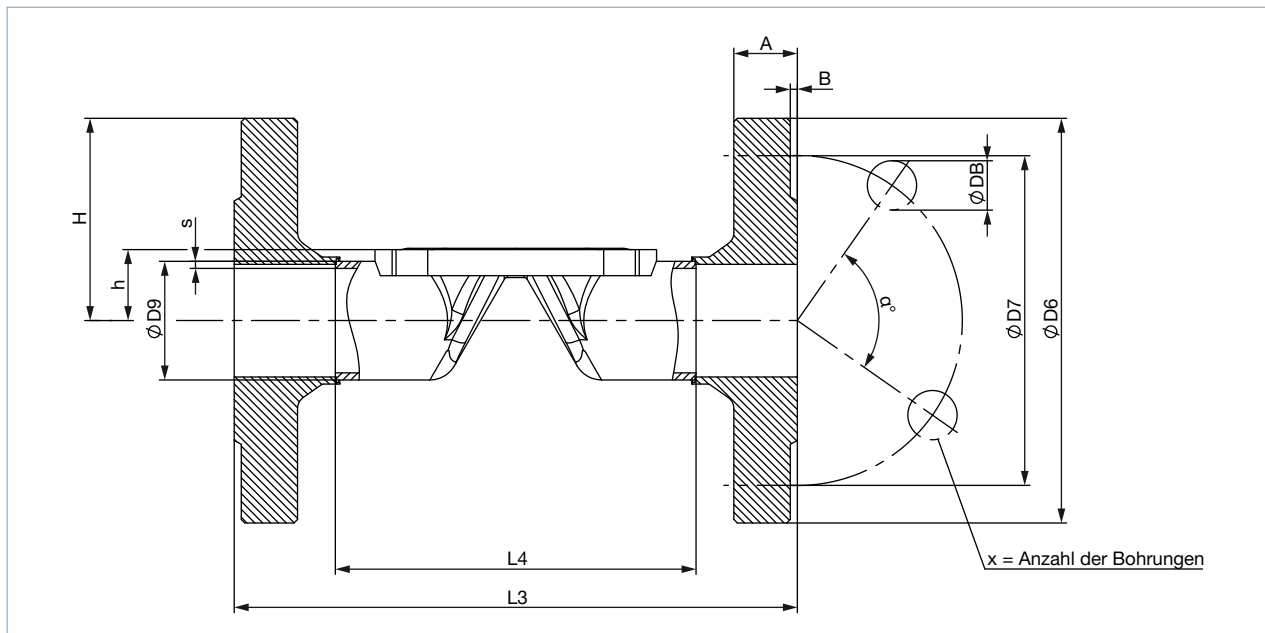

Diaphragm size	L4	L3	s3	ØD9	ØD6	ØD7	a°	ØDB	A	B	X	Product key ^{1.)}
DIN EN 1092-1												
15	76.5	130	1.6	21.3	76.5	65.0	90	14	16	2	4	FD22
20	92.5	150	1.6	26.9	92.5	75.0	90	14	18	2	4	FD23
25	102.5	160	2.0	33.7	102.5	85.0	90	14	18	2	4	FD24
32	122.5	180	2.0	42.4	122.5	100.0	90	18	18	2	4	FD25
40	136.5	200	2.0	48.3	136.5	110.0	90	18	18	3	4	FD26
50	160.5	230	2.0	60.3	160.5	125.0	90	18	20	3	4	FD27
ANSI B16.5												
15	67.0	130	1.6	21.3	89	60.5	90	15.7	11.2	1.6	4	FA02
25	106.0	160	2.0	33.7	108	79.2	90	15.7	14.2	1.6	4	FA04
40	128.0	200	2.0	48.3	127	98.6	90	15.7	17.5	1.6	4	FA06
50	151.0	230	2.0	60.3	152	120.7	90	19.1	19.1	1.6	4	FA07
JIS 10K												
15	89	130	1.6	21.3	95	70	90	15	12	1	4	FJ02
20	103	150	1.6	26.9	100	75	90	15	14	1	4	FJ02
25	116	160	2.0	33.7	125	90	90	19	14	1	4	FJ03
40	147	200	2.0	48.3	140	105	90	19	16	2	4	FJ05
50	175	230	2.0	60.3	155	120	90	19	16	2	4	FJ06

1.) This information is part of the product key (see product enquiry form at the end of this data sheet)

4.8. Cast body (VG) with welded connection

Note:

- Dimensions in mm, unless otherwise stated
- For detailed information on the draining angle, please refer to the “Additional manual Type 2xxx 3xxx” on our website (see [operating instructions](#) ▶).

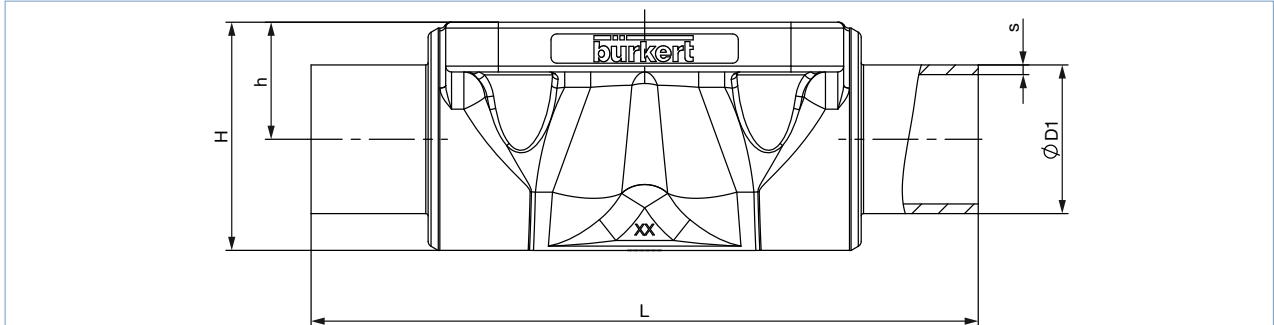

Diaphragm size	Port connection DN	ØD1	s	L	h	H	Product key ¹⁾
DIN EN ISO 1127/ISO 4200/DIN 11866 series B							
8	8	13.5	1.6	90	9.6	18.5	SA40
8	10	17.2	1.6	90	9.6	18.6	SA41
15	15	21.3	1.6	110	13.5	25.0	SA42
20	15	21.3	1.6	119	18.0	32.9	SA42
20	20	26.9	1.6	119	18.0	32.7	SA43
25	25	33.7	2.0	129	20.0	39.0	SA44
40	32	42.4	2.0	161	28.6	55.0	SA45
40	40	48.3	2.0	161	28.6	55.0	SA46
50	50	60.3	2.0	192	35.5	68.0	SA47
65	65	76.1	2.0	192	43.0	82.0	SA48
80	80	76.1	2.0	250	51.0	101.0	SA48
80	80	88.9	2.3	250	51.0	101.0	SA49
100	100	114.3	2.3	295	63.5	123.5	SA39
DIN 11850 series 2/DIN 11866 series A/DIN EN 10357 series A							
8	10	13	1.5	90	9.6	18.6	SD40
15	15	19	1.5	110	13.5	25.0	SD42
20	20	23	1.5	119	18.0	32.8	SD43
25	25	29	1.5	129	20.0	39.0	SD44
40	40	41	1.5	161	28.6	55.0	SD46
50	50	53	1.5	192	35.5	68.0	SD47
65	65	70	2.0	192	43.0	82.0	SD48
80	80	85	2.0	250	51.0	101.0	SD49
100	100	104	2.0	295	63.5	123.5	SD50

Type 2030_2031
Pneumatically operated diaphragm
valve with CLASSIC actuator



Diaphragm size	Port connection DN	ØD1	s	L	h	H	Product key ^{1.)}
ASME BPE/DIN 11866 series C							
8	¼"	6.35	0.89	64.5	9.6	18.6	SA90
8	⅜"	9.53	0.89	89	9.6	18.6 (18.9)	SA91
8	½"	12.7	1.65	89	9.6	18.6	SA92
15	¾"	19.05	1.65	102	13.5	25.0	SA93
20	¾"	19.05	1.65	119	18.0	32.8	SA93
20	1"	25.4	1.65	119	18.0	32.7	SODF
25	1"	25.4	1.65	114	20.0	39.0	SODF
40	1½"	38.1	1.65	140	28.6	55.0	SODH
50	2"	50.8	1.65	159	35.5	68.0	SODI
50	2½"	63.5	1.65	192	35.5	68.0	SODJ
65	2½"	63.5	1.65	192	43.0	82.0	SODJ
80	3"	76.2	1.65	250	51.0	101.0	SODK
100	4"	101.6	2.11	295	63.5	123.5	SODL
BS 4825							
8	8	6.35	1.20	64.5	9.6	18.6	SODB
8	10	9.53	1.20	89	9.6	18.6	SODC
8	15	12.7	1.20	89	9.6	18.6	SODD
15	20	19.05	1.20	102	14.0	25.5	SODE
20	25	25.4	1.65	119	18.0	32.8	SODF
25	25	25.4	1.65	114	20.0	39.0	SODF
40	40	38.1	1.65	140	28.6	55.0	SODH
50	50	50.8	1.65	159	35.5	68.0	SODI
50	65	63.5	1.65	192	35.5	68.0	SODJ
65	65	63.5	1.65	192	43.0	82.0	SODJ
80	80	76.2	1.65	250	51.0	101.0	SODK
100	100	101.6	2.11	295	63.5	123.5	SODL
SMS 3008							
20	25	25	1.2	119	18.0	32.8	SA60
25	25	25	1.2	129	20.0	39.0	SA60
40	40	38	1.2	161	28.6	55.0	SA62
50	50	51	1.2	192	35.5	68.0	SA63
DIN 11850 series 0							
8	4	6	1.0	90	9.6	18.6	SC40
8	6	8	1.0	90	9.6	18.6	SC41
8	8	10	1.0	90	9.6	18.6	SC42
15	15	18	1.5	110	13.5	25.0	SC43
20	20	22	1.5	119	18.0	32.8	SC44
25	25	28	1.5	129	20.0	39.0	SC45
25	32	34	1.5	129	20.0	39.0	SC46
40	40	40	1.5	161	28.6	56.0	SC47
50	50	52	1.5	192	35.5	68.0	SC48

1.) This information is part of the product key (see product enquiry form at the end of this data sheet)

DTS 1000450587 EN Version: B Status: RL (released | freigegeben | valide) printed: 05.02.2021

4.9. Cast body (VG) with clamp connection

Note:

- Dimensions in mm, unless otherwise stated
- For detailed information on the draining angle, please refer to the “Additional manual Type 2xxx 3xxx” on our website (see **operating instructions** ▶).

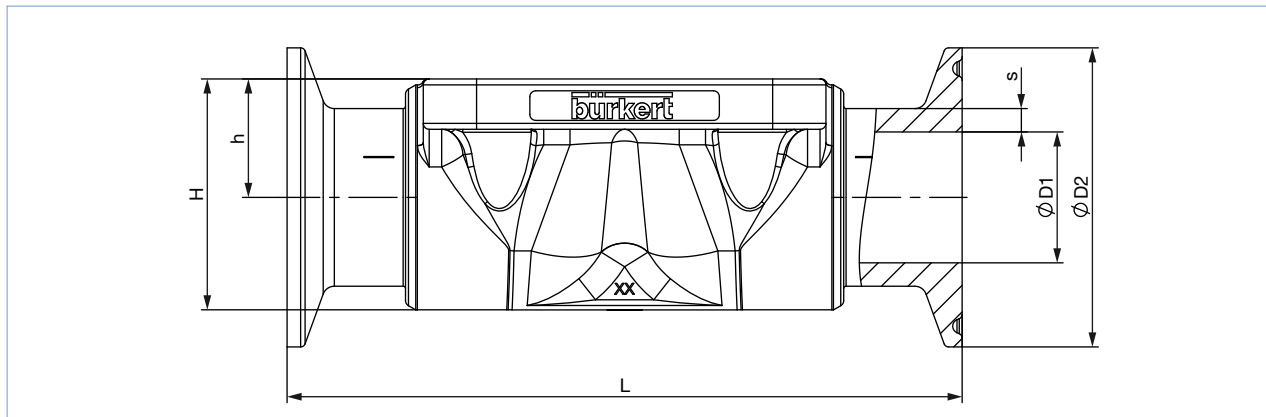

Diaphragm size	Port connection DN	ØD1	s	ØD2	L	h	H	Product key ^{1.)}
DIN 32676 series B (ISO pipe)								
25	25	33.7	2	50.5	129	20.0	39.0	TC44
40	40	48.3	2	64.0	161	28.6	55.0	TC46
50	50	60.3	2	77.5	192	35.5	68.0	TC47
DIN 32676 series A (DIN pipe)								
15	15	19	1.5	34.0	110	13.5	25.0	TD42
20	20	23	1.5	34.0	119	18.0	32.8	TD43
25	25	29	1.5	50.5	129	20.0	39.0	TD44
40	40	41	1.5	50.5	161	28.6	55.0	TD46
50	50	53	1.65	64.0	192	35.5	68.0	TD47
ASME BPE								
8	3/8"	9.53	0.89	25.0	89	9.6	18.6	TG01
8	1/2"	12.7	1.65	25.0	89	9.6 (9.3)	18.6	TG02
15	3/4"	19.05	1.65	25.0	102	13.5	23.0	TG03
20	3/4"	19.05	1.65	25.0	117	18.0	25.0	TG03
25	1"	25.4	1.65	50.5	114	18.0	40.0	TG04
40	1 1/2"	38.1	1.65	50.5	140	28.6	55.0	TG05
50	2"	50.8	1.65	64.0	159	35.5	68.0	TG06
50	2 1/2"	63.5	1.65	77.5	190	35.5	68.0	TG07
65	2 1/2"	63.5	1.65	77.5	249.2	43.0	82.0	TG07
80	3"	76.2	1.65	91	306.2 (222)	51.0	101.0	TG08
100	4"	101.6	2.11	119	352.2	63.5	123.5	TG09
BS 4825: Clamp BS 4825 - 3/pipe BS 4825 - 1								
8	15	12.7	1.2	25	89	9.6	18.9	TH42
15	20	19.05	1.2	25	102	13.5	25.0	TH43
25	25	25.4	1.65	50.5	114	20.0	39.0	TG04
40	40	38.1	1.65	50.5	140	28.6	55.0	TG05
50	50	50.8	1.65	64.0	159	35.5	68.0	TG06
50	65	63.5	1.65	77.5	190	35.5	68.0	TG07
Clamp 34.0 similar to DIN 32676 series B (ISO pipe)								
15	15	21.3	1.6	34	110	13.5	25.0	TC42

1.) This information is part of the product key (see product enquiry form at the end of this data sheet)

4.10. Plastic body (PV; PD; PP) with spigot connection

Note:

Dimensions in mm, unless otherwise stated

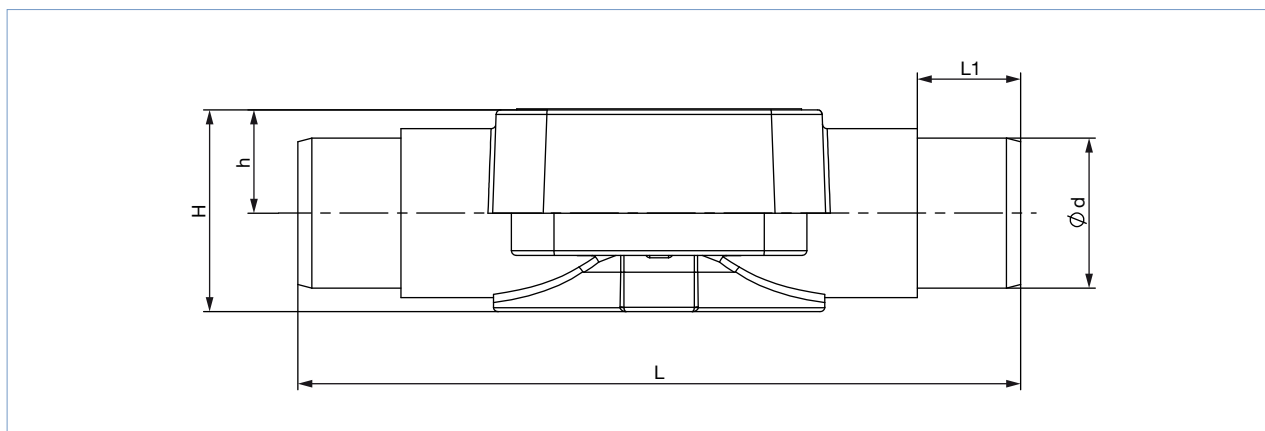

Diaphragm size	Ød	Wall thick-ness	h	H	L	L1	Product key ^{1.)}
PVC-U (PV)							
15	20	2.5	15	29	124	16	KS25
20	25	2.5	18.5	36	144	19	KS26
25	32	3.5	22	43	154	22	KS27
32	40	4	27	52.5	174	26	KS28
40	50	5	33	65.5	194	31	KS29
50	63	6.5	40	79	224	44	KS30
PVDF (PD) and PP (PP)							
15	20	2.5	15	29	124	16	SS25
20	25	2.5	18.5	36	144	19	SS26
25	32	3.5	22	43	154	22	SS27
32	40	4	27	52.5	174	26	SS28
40	50	5	33	65.5	194	31	SS29
50	63	6.5	40	79	224	44	SS30

1.) This information is part of the product key (see product enquiry form at the end of this data sheet)

4.11. Plastic body (PV, PD, PP) with true union

Note:

Dimensions in mm, unless otherwise stated

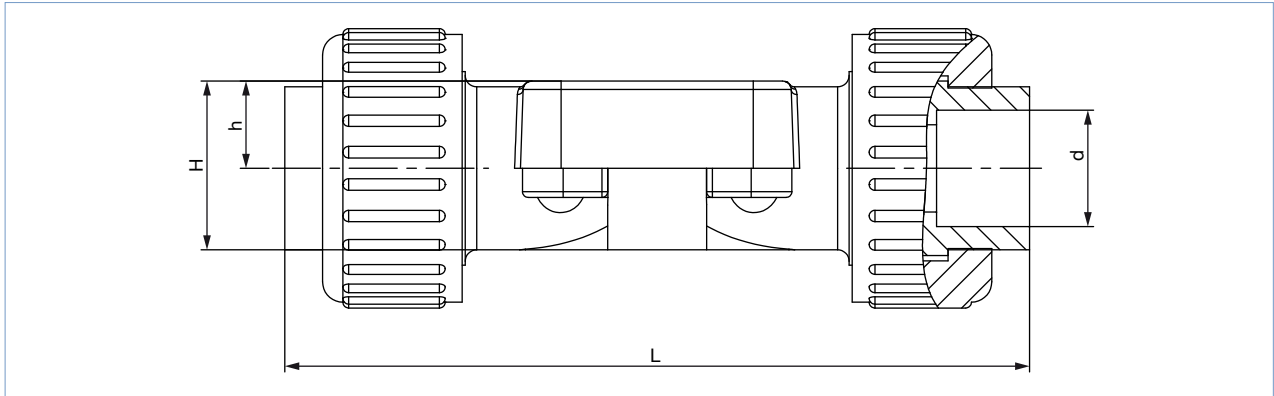

Diaphragm size	L	h	H	Ød	Product key ^{1.)}
PVC-U (PV)					
15	128	15	29	20	KM25
20	152	18.5	36	25	KM26
25	166	22	43	32	KM27
32	192	27	52.5	40	KM28
40	222	33	65.5	50	KM29
50	266	40	79	63	KM30
PVDF (PD)					
15	129	15	29	20	SM25
20	150	18.5	36	25	SM26
25	162	22	43	32	SM27
32	184	27	52.5	40	SM28
40	210	33	65.5	50	SM29
50	248	40	79	63	SM30
PP (PP)					
15	125	15	29	20	SM25
20	146	18.5	36	25	SM26
25	158	22	43	32	SM27
32	181	27	52.5	40	SM28
40	207	33	65.5	50	SM29
50	245	40	79	63	SM30

1.) This information is part of the product key (see product enquiry form at the end of this data sheet)

4.12. Plastic body (PV, PD, PP) with flange connection

Note:

Dimensions in mm, unless otherwise stated

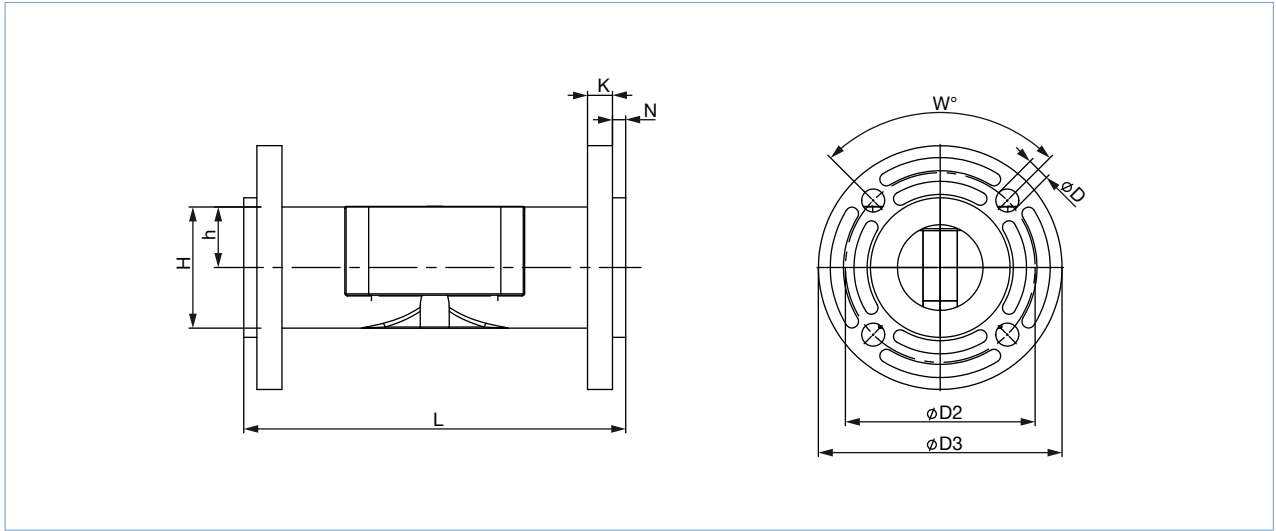

Diaphragm size	L	ØD2	ØD3	K	H	h	ØD	W	N	Product key ^{1.)}
PVC-U (PV), PVDF (PD) and PP (PP)										
15	130	65.5	96	12	–	–	14	4x90°	5.9	FL24
20	150	75	105	14	–	–	14	4x90°	6.9	FL25
25	160	85	115	15	–	–	14	4x90°	6.9	FL26
32	180	100	140	17	–	–	18	4x90°	7.9	FL27
40	200	110	150	17	–	–	18	4x90°	8	FL28
50	230	125	165	18	–	–	18	4x90°	9	FL29
65	290	145	185	19	92	47	18	4x90°	10	FL30
80	310	160	200	36	107	50	18	8x45°	–	FF31
100	350	180	225	35	134.5	65.5	18	8x45°	–	FF31

1.) This information is part of the product key (see product enquiry form at the end of this data sheet)

5. Performance specifications

5.1. Flow characteristics

Note:

- The K_v values may vary slightly with different actuator sizes and diaphragm materials.
- Further K_v values on request
- Flow rate: K_v value water (m³/h) for elastomer diaphragm
- Measurement at +20 °C, 4 bar at valve inlet and 3 bar at valve outlet

Forged body (VS)

Dia- phragm size	Port connection		K_v value [m ³ /h]					
			DIN EN ISO 1127 ISO 4200 DIN 11866 series B	DIN 11850 series 2 DIN 11866 series A DIN EN 10357 series A	ASME BPE DIN 11866 series C	DIN 11850 series 0	BS4825	SMS3008
DN	[mm]	[inch]	[m ³ /h]	[m ³ /h]	[m ³ /h]	[m ³ /h]	[m ³ /h]	[m ³ /h]
8	6	1/8"	–	–	–	1.1	–	–
8	8	1/4"	1.5	–	0.7	1.7	0.5	–
8	10	3/8"	1.5	1.5	1.6	–	1.4	–
8	15	1/2"	–	–	1.5	–	–	–
15	10	3/8"	5.5	3.5	–	–	–	–
15	15	1/2"	6.5	6.5	3.1	–	3.7	–
15	20	3/4"	–	–	6.5	–	–	–
20	20	3/4"	12.5	12.4	8.4	–	8.9	–
25	25	1"	18	20	15.5	–	15.5	16
40	32	1 1/4"	–	34	–	–	–	–
40	40	1 1/2"	41	40	37	–	37	38
50	50	2"	66	66	66	–	66	66
50	65	2 1/2"	–	–	66	–	66	66

Tube valve body (VP)

Dia- phragm size	Port connection		K_v value [m ³ /h]		
			DIN EN ISO 1127 ISO 4200 DIN 11866 series B	DIN 11850 series 2 DIN 11866 series A DIN EN 10357 series A	ASME BPE DIN 11866 series C
DN	[mm]	[inch]	[m ³ /h]	[m ³ /h]	[m ³ /h]
8	8	1/4"	1.9	–	–
8	10	3/8"	–	1.9	–
8	15	1/2"	–	–	1.8
15	10	3/8"	–	–	7.1
15	15	1/2"	7.2	7.4	–
15	20	3/4"	–	7.4	–
20	20	3/4"	13.5	–	–
20	25	1"	–	14.9	12.8
25	32	1 1/4"	–	22.3	–
25	25	1"	20.8	–	–
32	40	1 1/2"	–	34.8	31
40	40	1 1/2"	47.9	–	–
40	50	2"	–	46.2	43
50	50	2"	69.7	–	–

Cast body (VG)

Diaphragm size	Port connection		K _v value
DN	[mm]	[inch]	[m ³ /h]
8	8	¼"	1
15	15	½"	5.6
20	20	¾"	10.7
25	25	1"	14.6
40	40	1½"	35
50	50	2"	47

Plastic body (PV; PD; PP)

Diaphragm size	Port connection		K _v value
DN	[mm]	[inch]	[m ³ /h]
15	15	½"	3
20	20	¾"	7
25	25	1"	11.4
32	32	1¼"	17
40	40	1½"	24.5
50	50	2"	41.5

5.2. Medium pressure

Information for control function A

Note:

- For low operating pressures, optional versions with reduced spring force (**EC04**) are recommended.
- Pressure data [bar]: Overpressure to atmospheric pressure. Valve closes dynamically against max. operating pressure.
- Information for control function B and I on request.

Diaphragm size	Actuator size Ø	Pilot pressure	Max. operating pressure for seal material	
			EPDM, FKM	PTFE/EPDM, advanced PTFE/EPDM, GYLON®/EPDM laminated
DN	[mm]	[bar]	[bar]	[bar]
8	40 (C)	5.0...7	10	10
15	50 (D)	5.0...7	8.5	5
	63 (E)	5.0...7	10	10
20	63 (E)	5.5...7	10	5
	80 (F)	5.0...7	10	10
25	80 (F)	5.5...7	10	7.5
32	100 (G)	5.5...7	10	8
40	100 (G)	5.5...7	6.5	6 ^{1.)}
	125 (H)	5.5...7	10	10
50	125 (H)	5.5...7	8	7
65	175 (K)	5.0...6	8	5
80	175 (K)	5.0...6	5	4.5
	225 (L)	5.0...6	10	7 ^{2.)}
100	225 (L)	5.0...6	8	4

1.) Max. operating pressure for GYLON®/EPDM laminated is 4 bar

2.) Max. operating pressure for GYLON®/EPDM laminated is 8.5 bar

6. Product accessories

Electrical position feedback	
Type 8697 ▶ Actuator size Ø 40...225 mm	Description
	<p>The position feedback Type 8697 is designed for integrated mounting on process valves of the CLASSIC series and especially for the requirements of hygienic process environments. Mechanical or inductive limit switches detect the valve position.</p> <p>Features</p> <ul style="list-style-type: none">• Compact design• LED position indicator• Mechanical or inductive limit switches for end position registering• Easy to clean chemically resistant housing featuring IP65/IP67, 4X Rating• Optional intrinsically safe version acc. to ATEX/IECEX <p>Customer benefits</p> <ul style="list-style-type: none">• Easy and quick installation• High level of signal reliability thanks to self adjusting limit switches• Minimised space requirement in the plant piping for more flexibility in plant design

7. Networking and combination with other Bürkert products

The On/Off CLASSIC valve system, Type 8801-DA (alternatively 8801-DB), consists of diaphragm valve, Type 2030 (alternatively 2031), and position feedback, Type 8697.

Note:

- You order two components and receive a completely assembled and tested valve.

Example:

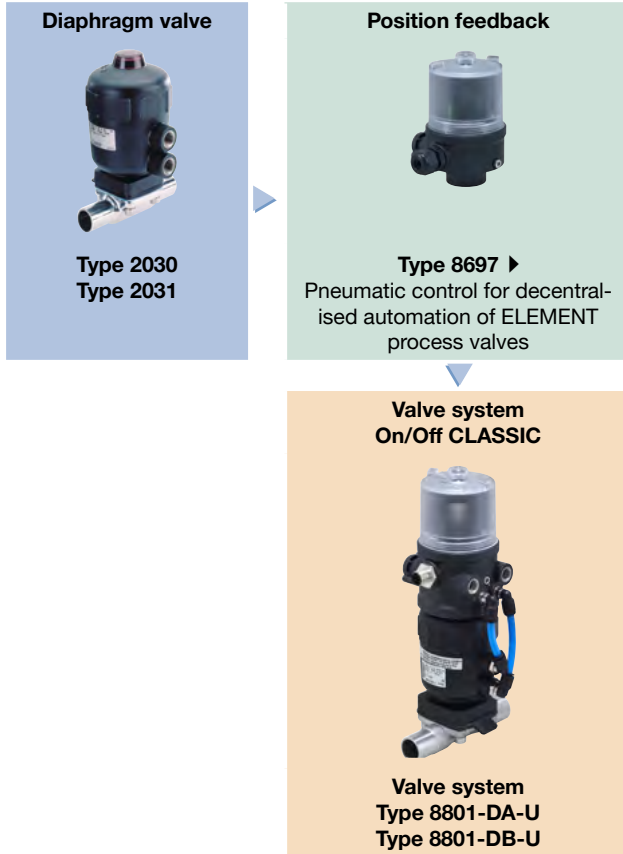

8. Ordering information

8.1. Bürkert eShop – Easy ordering and quick delivery



Bürkert eShop – Easy ordering and fast delivery

You want to find your desired Bürkert product or spare part quickly and order directly? Our online shop is available for you 24/7. Sign up and enjoy all the benefits.

[Order online now](#)

8.2. Bürkert product filter



Bürkert product filter – Get quickly to the right product

You want to select products comfortably based on your technical requirements? Use the Bürkert product filter and find suitable articles for your application quickly and easily.

[Try out our product filter](#)

8.3. Bürkert product enquiry form

Bürkert product enquiry form: Would you like to make a specific product enquiry based on your technical requirements? Please use our product enquiry form **at the end of this data sheet**. There you will find all the information relevant to your Bürkert contact person that will help us to process your enquiry in the best possible way.

Bürkert specification key: In our product enquiry form you will find a complete explanation of the composition of our specification key. You will find our product enquiry form **at the end of this data sheet**.

Bürkert – Close to You

For up-to-date addresses
please visit us at
www.burkert.com

DTS 1000450587 EN Version: B Status: RL (released | freigegeben | validé) printed: 05.02.2021



Product Enquiry Form
Diaphragm valve with straight
way valve, T-valve or tank bottom
valve



Product Enquiry Form - Diaphragm valve with globe valve, T-valve or
tank bottom valve

Thank you for your interest in our products! In order to provide you with optimum advice, please fill out the following form and send it to your **Bürkert representative** or e-mail address: info@burkert.com. All information submitted will of course be kept strictly confidential.

Please fill in the **required fields!** *

***Note:** The interactive functions of this PDF may be restricted depending on the PDF reader used.

Personal Information			
Company		Contact person	
Customer no.		Department	
Street		Postcode / Town	
Telephone no.		Email	

Delivery
Required delivery date

Operating data					
Process medium					
Medium	Liquid	Steam	Gas	CIP	SIP
Medium temperature	T _{med}				
Medium pressure	P _{med}				

Valve data				
Surface quality (valid for stainless steel)	Standard:	Ra 0.5 internal	Ra 0.38 e-pol internal	Plastic
	Non standard:	internal	external	
Body material				
Body design	2 way valve	T-valve	Tank bottom valve	
Seal material	EPDM	PTFE	GYLON®	others
Nominal diameter	DN			
Pilot pressure	min.		max.	
Connection	Weld end	EN ISO 1127 / ISO 4200 DIN 11866 R. B	DIN 11850 DIN 11866 R. A	ASME BPE DIN 11866 R. C
	Clamp connection	DIN 32676 R. B (ISO tube (ISO4200))	DIN 32676 R. A (DIN tube (DIN11850))	ASME BPE
	Plastic	Flange	Threated	Spigot
	Others			

Article no. (if known)
Are you interested in ordering a complete Valve System Open/Close or Continuous? For more information on Valve Systems Open/Close or Continuous, please visit our Website ►.

Additional Requirements / Comment

DTS 1000450587 EN Version: B Status: RL (released | freigegeben | valide) printed: 05.02.2021

Specification key



Note:





- Please fill out this Product Inquiry Form as completely as possible!
- For more information on Valve Systems Open/Close or Continuous, please visit our **Website** ►.
- See **Specification key - Examples** how to fill in the specification key.





Key Feature	Quantity	Type	Control function	Nominal diameter diaphragm	Diaphragm material	Body material	Port connection	Port connection	Actuator version	Actuator size	Pilot air port	Actuator	Variable	Variable	Variable	
		TYP	SF	DN	DWST	WKST	LTA1	LTA2	ANTA	ANTG	STLA	ANTR	VAR1	VAR2	VAR3	
Key No. →		1	2	3	4	5	6	6	7	8	9	10	V1	V2	V3	
1 Selection →													*			
	Comments															
2 Selection →													*			
	Comments															
3 Selection →													*			
	Comments															
4 Selection →													*			
	Comments															
5 Selection →													*			
	Comments															
6 Selection →													*			
	Comments															

DTS 1000450587 EN Version: B Status: RL (released | freigegeben | valide) printed: 05.02.2021

Specification key - Examples

2 way diaphragm valve					
Type 2030 ▶ CLASSIC with plastic body 	Type 2031 ▶ CLASSIC with stainless steel body 	Type 2063 ▶ INOX with stainless steel body 	Type 2103 ▶ ELEMENT with stainless steel or plastic body 	Type 3232 ▶ Manually operated with plastic body 	Type 3233 ▶ Manually operated with stainless steel body 

T-diaphragm valve			
Type 2032 ▶ CLASSIC T-valve 	Type 2064 ▶ INOX T-valve 	Type 2104 ▶ ELEMENT T-valve 	Type 3234 ▶ Manually operated T-valve 

Tank bottom diaphragm valve			
Type 2033 ▶ CLASSIC Tank bottom valve 	Type 2065 ▶ INOX Tank bottom valve 	Type 2105 ▶ ELEMENT Tank bottom valve 	Type 3235 ▶ Manually operated tank bottom valve 

	Type	Control function	Nominal diameter diaphragm	Diaphragm material	Body material	Port connection	Port connection	Actuator version	Actuator size	Pilot air port	Actuator	Variable	Variable	Variable
Key Feature	TYP	SF	DN	DWST	WKST	LTA1	LTA2	ANTA	ANTG	STLA	ANTR	VAR1	VAR2	VAR3
Key No. →	1	2	3	4	5	6	6	7	8	9	10	V1	V2	V3

2 way diaphragm valve														
Type 2030 CLASSIC	2030	A	20.0	AD	PV	KM26	-	C	E	-	-			
Type 2031 CLASSIC	2031	A	20.0	AD	VS	SA93	-	C	E	-	-	NK52	NO14	
Type 2063 INOX	2063	A	20.0	AD	VS	SA93	-	H	M	-	-	NK52	NO14	
Type 2103 ELEMENT	2103	A	20.0	AD	PV	KM26	-	G	M	FA01	-			
Type 2103 ELEMENT	2103	A	20.0	AD	VS	SA93	-	G	M	FA01	-	NK52	NO14	
Type 3232	3232	-	20.0	AD	PV	KM26	-	-	-	-	D050			
Type 3233	3233	-	20.0	AD	VS	SA93	-	-	-	-	D051	NK52	NO14	
T-diaphragm valve														
Type 2032 CLASSIC	2032	A	20.0	AD	VH	SODH	SA93	D	E	-	-	NK52	NO14	
Type 2064 INOX	2064	A	20.0	AD	VH	SODH	SA93	-	M	-	-	NK52	NO14	
Type 2104 ELEMENT	2104	A	20.0	AD	VH	SODH	SA93	-	M	FA01	-	NK52	NO14	
Type 3234	3234	-	20.0	AD	VH	SODH	SA93	-	-	-	D050	NK52	NO14	
Tank bottom diaphragm valve														
Type 2033 CLASSIC	2033	A	20.0	AD	VH	SA93	-	D	F	-	-	NK52	NO14	
Type 2065 INOX	2065	A	20.0	AD	VH	SA93	-	-	M	-	-	NK52	NO14	
Type 2105 ELEMENT	2105	A	20.0	AD	VH	SA93	-	-	M	FA01	-	NK52	NO14	
Type 3235	3235	-	20.0	AD	VH	SA93	-	-	-	-	D050	NK52	NO14	

1.) NK52, NOxx only for stainless steel bodies

Key Legend

Note:

- Other versions on request
- Available Type sizes see corresponding data sheet

Key no. 2: Control function (SF)	
A	Closed with spring force
B	Open with spring force
I	Without pressure spring

Key no. 3: Nominal diameter diaphragm (DN)			
8	25	50	100
15	32	65	
20	40	80	

Key no. 4: Diaphragm material (DWST)	
AD	EPDM
EA	PTFE/EPDM
EU	Advanced PTFE/EPDM laminated
ER	Gylon®/EPDM laminated

Key no. 5: Body material (WKST)	
PD	PVDF (Polyvinylidene fluoride)
PP	PP (Polypropylene)
PV	PVC-U (Polyvinyl chloride)
VG	Stainless steel precision casting 1.4435/316L
VH	Stainless steel block material 1.4435/316L
VI	Stainless steel block material 1.4435 BN2/316L ASME BPE
VP	Stainless steel tube 1.4435 BN2/316L
VS	Stainless steel-forged 1.4435 BN2/316L ASME BPE

Key no. 6: Port connection (LTA1, LTA2)	
Listed in detail below	

Key no. 7: Actuator version (ANTA)	
C	PA actuator (only CLASSIC)
D	PPS actuator (only CLASSIC)
G	ELEMENT design actuator (only ELEMENT)
H	St. St. actuator (only INOX)

Key no. 8: Actuator size (ANTG)	
B	ø 32
C	ø 40
D	ø 50
E	ø 63
F	ø 80
G	ø 100
H	ø 125
K	ø 175
L	ø 225
M	ø 70
N	ø 90
P	ø 130

Key no. 9: Pilot air port (ELEMENT) (STLA)	
FA01	Pilot air port Push-In 6/4, 1/4"
FA02	Pilot air port G1/8
FA03	Interface ELEMENT control

Key no. 10: Actuator (ANTR)	
D050	Handwheel and attachment PPS
D051 ^{1.)}	Handwheel PPS and attachment St. St.
D052 ^{2.)}	Handwheel and attachment St. St.

1.) Alternatively D058

2.) Alternatively D059 or D102

Key no. V1, V2, ...: Variable code (VAR1, VAR2, VAR3)	
NK52 ^{3.)}	Acceptance test certificate 3.1 according to EN 10204
NO14 ^{3.)}	Mechanically polished Ra ≤ 0.5 µm (ASME BPE SF1)
NO17 ^{3.)}	Electropolished Ra ≤ 0.38 µm (ASME BPE SF4 / DIN HE4)
NO06 ^{3.)}	Mechanically polished Ra ≤ 0.76 µm (ASME BPE SF3 / DIN H2)
NO16 ^{3.)}	Electropolished Ra ≤ 0.6 µm (ASME BPE SF6)
EC04	Reduced spring force

3.) NK52, NOxx only for stainless steel bodies

Key no. 6: Port connection (LTA)

Weld connection								
DN [mm]	EN ISO 1127 / ISO 4200 DIN 11866 R. B	SMS 3008	DIN 11850 R. 0	DIN 11850 R. 1	DIN 11850 R. 2 DIN 11866 R. A	DIN 11850 R. 3	BS4825	ASME BPE DIN 11866 R. C
4	-	-	SC40-6.0x1.0	-	-	-	-	-
6	SA78-10.2x1.6	-	SC41-8.0x1.0	-	-	-	-	SA89-3.17x0.56
8	SA40-13.5x1.6	-	SC42-10.0x1.0	-	-	-	SODB-6.35x1.2	SA90-6.35x0.89
10	SA41-17.2x1.6	-	-	SF40-12.0x1.0	SD40-13.0x1.5	SE40-14.0x2.0	SODC-9.53x1.2	SA91-9.53x0.89
15	SA42-21.3x1.6	SA58-12.0x1.0	SC43-18.0x1.5	SF41-18.0x1.0	SD42-19.0x1.5	SE42-20.0x2.0	SODD-12.7x1.2	SA92-12.7x1.65
20	SA43-26.9x1.6	SA59-18.0x1.0	SC44-22.0x1.5	SF42-22.0x1.0	SD43-23.0x1.5	SE43-24.0x2.0	SODE-19.05x1.2	SA93-19.05x1.65
25	SA44-33.7x2.0	SA60-25.0x1.2	SC45-28.0x1.5	SF43-28.0x1.0	SD44-29.0x1.5	SE44-30.0x2.0	-	SODF-25.4x1.65
32	SA45-42.4x2.0	SA61-33.7x1.2	SC46-34.0x1.5	SF44-34.0x1.0	SD45-35.0x1.5	SE45-36.0x2.0	-	-
40	SA46-48.3x2.0	SA62-38.0x1.2	SC47-40.0x1.5	SF45-40.0x1.0	SD46-41.0x1.5	SE46-42.0x2.0	-	SODH-38.1x1.65
50	SA47-60.3x2.0	SA63-51.0x1.2	SC48-52.0x1.5	SF46-52.0x1.0	SD47-53.0x1.5	SE47-54.0x2.0	-	SODI-50.8x1.65
65	SA48-76.1x2.0	SA64-63.5x1.6	-	-	SD48-70.0x2.0	-	-	SODJ-63.5x1.65
80	SA49-88.9x2.3	SA65-76.1x1.6	-	-	SD49-85.0x2.0	-	-	SODK-76.2x1.65
100	SA39-114.3x2.3	SA66-101.6x2.0	-	-	SD50-104.0x2.0	-	-	SODL-101.6x2.11

Product Enquiry Form
Diaphragm valve with straight
way valve, T-valve or tank bottom
valve



Clamp connection					
DN [mm]	Clamp 34,0 similar to DIN 32676 R. B (ISO tube (ISO4200))	DIN 32676 R. A (DIN tube (DIN11850))	DIN 32676 R. B (ISO tube (ISO4200))	ASME BPE	BS 4825 (Clamp BS 4825-3, tube BS 4825-1)
8	TC51-13.5×1.6 Cl: 34.0	TD40-10.0×1.0 Cl: 25.0	TC40-13.5×1.6 Cl: 25.0	TG 50-6.35×0.89 Cl: 25.0	-
10	TC41-17.2×1.6 Cl: 34.0	TD41-13.0×1.5 Cl: 34.0	TC53-17.2×1.6 Cl: 25.0	TG 01-9.53×0.89 Cl: 25.0	-
15	TC42-21.3×1.6 Cl: 34.0	TD42-19,0×1.5 Cl: 34.0	TC52-21.3×1.6 Cl: 50.5	TG 02-12.7×1.65 Cl: 25.0	TH42-12.7×1.2 Cl: 25.0
20	-	TD43-23.0×1.5 Cl: 34.0	TC43-26.9×1.6 Cl: 50.5	TG 03-19.05×1.65 Cl: 25.0	TH43-19.05×1.2 Cl: 25.0
25	-	TD44-29.0×1.5 Cl: 50.5	TC44-33.7×2.0 Cl: 50.5	TG 04-25.4×1.65 Cl: 50.5	-
32	-	-	-	-	-
40	-	TD46-41.0×1.5 Cl: 50.5	TC46-48.3×2.0 Cl: 64.0	TG 05-38.1×1.65 Cl: 50.5	-
50	-	TD47-53.0×1.5 Cl: 64.0	TC47-60.3×2.0 Cl: 77.5	TG 06-50.8×1.65 Cl: 64.0	-
65	-	-	TC48-76.1×2.0 Cl: 91.0	TG 07-63.5×1.65 Cl: 77.5	-
80	-	-	TC49-88.9×2.3 Cl: 106.0	TG 08-76.2x,65 Cl: 91.0	-
100	-	-	TC50-114.3×2.3 Cl: 130.0	TG 09-101.6×2.11 Cl: 119.0	-

Plastic connection					
DN [mm]	Welded connection socket (only WKST=PD, PP)	Welded connection threaded socket (only WKST=PD, PP)	Adhesive bond socket (only WKST=PV)	Adhesive bond threaded socket (only WKST=PV)	Loose-type flange (up to DN65) Fixed flange (from DN80)
15	SS25 - ø20	SM25 - ø20	KS25 - ø20	KM25 - ø20	FL24
20	SS26 - ø25	SM26 - ø25	KS26 - ø25	KM26 - ø25	FL25
25	SS27 - ø32	SM27 - ø32	KS27 - ø32	KM27 - ø32	FL26
32	SS28 - ø40	SM28 - ø40	KS28 - ø40	KM28 - ø40	FL27
40	SS29 - ø50	SM29 - ø50	KS29 - ø50	KM29 - ø50	FL28
50	SS30 - ø63	SM30 - ø63	KS30 - ø63	KM30 - ø63	FL29
65	-	-	-	-	FL30
80	-	-	-	-	FF31
100	-	-	-	-	FF32

DTS 1000450587 EN Version: B Status: RL (released | freigegeben | valide) printed: 05.02.2021

Control heads / pneumatic control for on/off process valves of the CLASSIC series

For actuator size ø40 to 225 mm

Electrical position feedback Type 8697 ▶



- Optical position indicator
- Mechanical or inductive limit switches for end position registering
- Optional intrinsically safe version acc. to ATEX / IECEx

Electrical connection

Cable gland

M12 connector^{1.)}

Number of end position feedback switches

2x Micro or inductive

Approvals

ATEX cat. 3GD, IECEx

ATEX cat. 2DG, IECEx

Without

Position feedback switch

Micro switch 24 V DC

Micro switch 50...225 V DC/AC

Inductive switch 3-wire PNP

Inductive switch 2-wire NAMUR

Inductive switch 2-wire 24 V DC

Without

1.) Applicable only with inductive switch 3-wire PNP